

SPICE FOR POWER  
ELECTRONICS AND  
ELECTRIC POWER

SECOND EDITION

# ELECTRICAL AND COMPUTER ENGINEERING

*A Series of Reference Books and Textbooks*

FOUNDING EDITOR

***Marlin O. Thurston***

Department of Electrical Engineering  
The Ohio State University  
Columbus, Ohio

1. Rational Fault Analysis, *edited by Richard Saeks and S. R. Liberty*
2. Nonparametric Methods in Communications, *edited by P. Papantoni-Kazakos and Dimitri Kazakos*
3. Interactive Pattern Recognition, *Yi-tzuu Chien*
4. Solid-State Electronics, *Lawrence E. Murr*
5. Electronic, Magnetic, and Thermal Properties of Solid Materials, *Klaus Schröder*
6. Magnetic-Bubble Memory Technology, *Hsu Chang*
7. Transformer and Inductor Design Handbook, *Colonel Wm. T. McLyman*
8. Electromagnetics: Classical and Modern Theory and Applications, *Samuel Seely and Alexander D. Poularikas*
9. One-Dimensional Digital Signal Processing, *Chi-Tsong Chen*
10. Interconnected Dynamical Systems, *Raymond A. DeCarlo and Richard Saeks*
11. Modern Digital Control Systems, *Raymond G. Jacquot*
12. Hybrid Circuit Design and Manufacture, *Roydn D. Jones*
13. Magnetic Core Selection for Transformers and Inductors: A User's Guide to Practice and Specification, *Colonel Wm. T. McLyman*
14. Static and Rotating Electromagnetic Devices, *Richard H. Engelmann*
15. Energy-Efficient Electric Motors: Selection and Application, *John C. Andreas*
16. Electromagnetic Compossibility, *Heinz M. Schlicke*
17. Electronics: Models, Analysis, and Systems, *James G. Gottling*
18. Digital Filter Design Handbook, *Fred J. Taylor*
19. Multivariable Control: An Introduction, *P. K. Sinha*
20. Flexible Circuits: Design and Applications, *Steve Gurley, with contributions by Carl A. Edstrom, Jr., Ray D. Greenway, and William P. Kelly*

21. Circuit Interruption: Theory and Techniques, *Thomas E. Browne, Jr.*
22. Switch Mode Power Conversion: Basic Theory and Design, *K. Kit Sum*
23. Pattern Recognition: Applications to Large Data-Set Problems, *Sing-Tze Bow*
24. Custom-Specific Integrated Circuits: Design and Fabrication, *Stanley L. Hurst*
25. Digital Circuits: Logic and Design, *Ronald C. Emery*
26. Large-Scale Control Systems: Theories and Techniques, *Magdi S. Mahmoud, Mohamed F. Hassan, and Mohamed G. Darwish*
27. Microprocessor Software Project Management, *Eli T. Fathi and Cedric V. W. Armstrong (Sponsored by Ontario Centre for Microelectronics)*
28. Low Frequency Electromagnetic Design, *Michael P. Perry*
29. Multidimensional Systems: Techniques and Applications, *edited by Spyros G. Tzafestas*
30. AC Motors for High-Performance Applications: Analysis and Control, *Sakae Yamamura*
31. Ceramic Motors for Electronics: Processing, Properties, and Applications, *edited by Relva C. Buchanan*
32. Microcomputer Bus Structures and Bus Interface Design, *Arthur L. Dexter*
33. End User's Guide to Innovative Flexible Circuit Packaging, *Jay J. Miniet*
34. Reliability Engineering for Electronic Design, *Norman B. Fuqua*
35. Design Fundamentals for Low-Voltage Distribution and Control, *Frank W. Kussy and Jack L. Warren*
36. Encapsulation of Electronic Devices and Components, *Edward R. Salmon*
37. Protective Relaying: Principles and Applications, *J. Lewis Blackburn*
38. Testing Active and Passive Electronic Components, *Richard F. Powell*
39. Adaptive Control Systems: Techniques and Applications, *V. V. Chalam*
40. Computer-Aided Analysis of Power Electronic Systems, *Venkatachari Rajagopalan*
41. Integrated Circuit Quality and Reliability, *Eugene R. Hnatek*
42. Systolic Signal Processing Systems, *edited by Earl E. Swartzlander, Jr.*
43. Adaptive Digital Filters and Signal Analysis, *Maurice G. Bellanger*
44. Electronic Ceramics: Properties, Configuration, and Applications, *edited by Lionel M. Levinson*

45. Computer Systems Engineering Management, *Robert S. Alford*
46. Systems Modeling and Computer Simulation, *edited by Naim A. Kheir*
47. Rigid-Flex Printed Wiring Design for Production Readiness, *Walter S. Rigling*
48. Analog Methods for Computer-Aided Circuit Analysis and Diagnosis, *edited by Takao Ozawa*
49. Transformer and Inductor Design Handbook: Second Edition, Revised and Expanded, *Colonel Wm. T. McLyman*
50. Power System Grounding and Transients: An Introduction, *A. P. Sakis Meliopoulos*
51. Signal Processing Handbook, *edited by C. H. Chen*
52. Electronic Product Design for Automated Manufacturing, *H. Richard Stillwell*
53. Dynamic Models and Discrete Event Simulation, *William Delaney and Erminia Vaccari*
54. FET Technology and Application: An Introduction, *Edwin S. Oxner*
55. Digital Speech Processing, Synthesis, and Recognition, *Sadaoki Furui*
56. VLSI RISC Architecture and Organization, *Stephen B. Furber*
57. Surface Mount and Related Technologies, *Gerald Ginsberg*
58. Uninterruptible Power Supplies: Power Conditioners for Critical Equipment, *David C. Griffith*
59. Polyphase Induction Motors: Analysis, Design, and Application, *Paul L. Cochran*
60. Battery Technology Handbook, *edited by H. A. Kiehne*
61. Network Modeling, Simulation, and Analysis, *edited by Ricardo F. Garzia and Mario R. Garzia*
62. Linear Circuits, Systems, and Signal Processing: Advanced Theory and Applications, *edited by Nobuo Nagai*
63. High-Voltage Engineering: Theory and Practice, *edited by M. Khalifa*
64. Large-Scale Systems Control and Decision Making, *edited by Hiroyuki Tamura and Tsuneo Yoshikawa*
65. Industrial Power Distribution and Illuminating Systems, *Kao Chen*
66. Distributed Computer Control for Industrial Automation, *Dobrovoje Popovic and Vijay P. Bhatkar*
67. Computer-Aided Analysis of Active Circuits, *Adrian Ioinovici*
68. Designing with Analog Switches, *Steve Moore*
69. Contamination Effects on Electronic Products, *Carl J. Tautscher*
70. Computer-Operated Systems Control, *Magdi S. Mahmoud*
71. Integrated Microwave Circuits, *edited by Yoshihiro Konishi*

72. Ceramic Materials for Electronics: Processing, Properties, and Applications, Second Edition, Revised and Expanded, *edited by Relva C. Buchanan*
73. Electromagnetic Compatibility: Principles and Applications, *David A. Weston*
74. Intelligent Robotic Systems, *edited by Spyros G. Tzafestas*
75. Switching Phenomena in High-Voltage Circuit Breakers, *edited by Kunio Nakanishi*
76. Advances in Speech Signal Processing, *edited by Sadaoki Furui and M. Mohan Sondhi*
77. Pattern Recognition and Image Preprocessing, *Sing-Tze Bow*
78. Energy-Efficient Electric Motors: Selection and Application, Second Edition, *John C. Andreas*
79. Stochastic Large-Scale Engineering Systems, *edited by Spyros G. Tzafestas and Keigo Watanabe*
80. Two-Dimensional Digital Filters, *Wu-Sheng Lu and Andreas Antoniou*
81. Computer-Aided Analysis and Design of Switch-Mode Power Supplies, *Yim-Shu Lee*
82. Placement and Routing of Electronic Modules, *edited by Michael Pecht*
83. Applied Control: Current Trends and Modern Methodologies, *edited by Spyros G. Tzafestas*
84. Algorithms for Computer-Aided Design of Multivariable Control Systems, *Stanoje Bingulac and Hugh F. VanLandingham*
85. Symmetrical Components for Power Systems Engineering, *J. Lewis Blackburn*
86. Advanced Digital Signal Processing: Theory and Applications, *Glenn Zelniker and Fred J. Taylor*
87. Neural Networks and Simulation Methods, *Jian-Kang Wu*
88. Power Distribution Engineering: Fundamentals and Applications, *James J. Burke*
89. Modern Digital Control Systems: Second Edition, *Raymond G. Jacquot*
90. Adaptive IIR Filtering in Signal Processing and Control, *Phillip A. Regalia*
91. Integrated Circuit Quality and Reliability: Second Edition, Revised and Expanded, *Eugene R. Hnatek*
92. Handbook of Electric Motors, *edited by Richard H. Engelmann and William H. Middendorf*
93. Power-Switching Converters, *Simon S. Ang*
94. Systems Modeling and Computer Simulation: Second Edition, *Naim A. Kheir*
95. EMI Filter Design, *Richard Lee Ozenbaugh*
96. Power Hybrid Circuit Design and Manufacture, *Haim Taraseiskey*

97. Robust Control System Design: Advanced State Space Techniques, *Chia-Chi Tsui*
98. Spatial Electric Load Forecasting, *H. Lee Willis*
99. Permanent Magnet Motor Technology: Design and Applications, *Jacek F. Gieras and Mitchell Wing*
100. High Voltage Circuit Breakers: Design and Applications, *Ruben D. Garzon*
101. Integrating Electrical Heating Elements in Appliance Design, *Thor Hegbom*
102. Magnetic Core Selection for Transformers and Inductors: A User's Guide to Practice and Specification, Second Edition, *Colonel Wm. T. McLyman*
103. Statistical Methods in Control and Signal Processing, *edited by Tohru Katayama and Sueo Sugimoto*
104. Radio Receiver Design, *Robert C. Dixon*
105. Electrical Contacts: Principles and Applications, *edited by Paul G. Slade*
106. Handbook of Electrical Engineering Calculations, *edited by Arun G. Phadke*
107. Reliability Control for Electronic Systems, *Donald J. LaCombe*
108. Embedded Systems Design with 8051 Microcontrollers: Hardware and Software, *Zdravko Karakehayov, Knud Smed Christensen, and Ole Winther*
109. Pilot Protective Relaying, *edited by Walter A. Elmore*
110. High-Voltage Engineering: Theory and Practice, Second Edition, Revised and Expanded, *Mazen Abdel-Salam, Hussein Anis, Ahdab El-Morshedy, and Roshdy Radwan*
111. EMI Filter Design: Second Edition, Revised and Expanded, *Richard Lee Ozenbaugh*
112. Electromagnetic Compatibility: Principles and Applications, Second Edition, Revised and Expanded, *David Weston*
113. Permanent Magnet Motor Technology: Design and Applications, Second Edition, Revised and Expanded, *Jacek F. Gieras and Mitchell Wing*
114. High Voltage Circuit Breakers: Design and Applications, Second Edition, Revised and Expanded, *Ruben D. Garzon*
115. High Reliability Magnetic Devices: Design and Fabrication, *Colonel Wm. T. McLyman*
116. Practical Reliability of Electronic Equipment and Products, *Eugene R. Hnatek*
117. Electromagnetic Modeling by Finite Element Methods, *João Pedro A. Bastos and Nelson Sadowski*
118. Battery Technology Handbook, Second Edition, *edited by H. A. Kiehne*
119. Power Converter Circuits, *William Shepherd and Li Zhang*

120. Handbook of Electric Motors: Second Edition, Revised and Expanded, *edited by Hamid A. Toliyat and Gerald B. Kliman*
121. Transformer and Inductor Design Handbook, *Colonel Wm T. McLyman*
122. Energy Efficient Electric Motors: Selection and Application, Third Edition, Revised and Expanded, *Ali Emadi*
123. Power-Switching Converters, Second Edition, *Simon Ang and Alejandro Oliva*
124. Process Imaging For Automatic Control, *edited by David M. Scott and Hugh McCann*
125. Handbook of Automotive Power Electronics and Motor Drives, *Ali Emadi*
126. Adaptive Antennas and Receivers, *edited by Melvin M. Weiner*
127. SPICE for Power Electronics and Electric Power, Second Edition, *Muhammad H. Rashid and Hasan M. Rashid*

# SPICE FOR POWER ELECTRONICS AND ELECTRIC POWER

SECOND EDITION

MUHAMMAD H. RASHID

*University of West Florida  
Pensacola, Florida, U.S.A.*

HASAN M. RASHID

*University of Florida  
Gainesville, Florida, U.S.A.*



Taylor & Francis

Taylor & Francis Group

Boca Raton London New York

---

A CRC title, part of the Taylor & Francis imprint, a member of the Taylor & Francis Group, the academic division of T&F Informa plc.

Published in 2006 by  
CRC Press  
Taylor & Francis Group  
6000 Broken Sound Parkway NW, Suite 300  
Boca Raton, FL 33487-2742

© 2006 by Taylor & Francis Group, LLC  
CRC Press is an imprint of Taylor & Francis Group

No claim to original U.S. Government works  
Printed in the United States of America on acid-free paper  
10 9 8 7 6 5 4 3 2 1

International Standard Book Number-10: 0-8493-3418-7 (Hardcover)  
International Standard Book Number-13: 978-0-8493-3418-4 (Hardcover)  
Library of Congress Card Number 2005049658

This book contains information obtained from authentic and highly regarded sources. Reprinted material is quoted with permission, and sources are indicated. A wide variety of references are listed. Reasonable efforts have been made to publish reliable data and information, but the author and the publisher cannot assume responsibility for the validity of all materials or for the consequences of their use.

No part of this book may be reprinted, reproduced, transmitted, or utilized in any form by any electronic, mechanical, or other means, now known or hereafter invented, including photocopying, microfilming, and recording, or in any information storage or retrieval system, without written permission from the publishers.

For permission to photocopy or use material electronically from this work, please access [www.copyright.com](http://www.copyright.com) (<http://www.copyright.com>) or contact the Copyright Clearance Center, Inc. (CCC) 222 Rosewood Drive, Danvers, MA 01923, 978-750-8400. CCC is a not-for-profit organization that provides licenses and registration for a variety of users. For organizations that have been granted a photocopy license by the CCC, a separate system of payment has been arranged.

**Trademark Notice:** Product or corporate names may be trademarks or registered trademarks, and are used only for identification and explanation without intent to infringe.

---

### Library of Congress Cataloging-in-Publication Data

---

Rashid, M. H.

SPICE for power electronics and electric power / Muhammad H. Rashid, Hasan M. Rashid.-- 2nd ed.

p. cm. -- (Electrical and computer engineering ; 126)

ISBN 0-8493-3418-7 (alk. paper)

1. Power electronics--Data processing. 2. Electronic circuit design--Data processing. 3. Electric circuit analysis--Data processing. 4. SPICE (Computer file) I. Rashid, Hasan M. II. Title. III. Series.

TK7881.15.R38 2005

621.31'7'0285--dc22

2005049658

---



Taylor & Francis Group  
is the Academic Division of T&F Informa plc.

Visit the Taylor & Francis Web site at  
<http://www.taylorandfrancis.com>

and the CRC Press Web site at  
<http://www.crcpress.com>

*To our family:  
Fa-eza, Farzana, and Hussain*

---

# Preface

Power electronics is normally offered as a technical elective. It is an application-oriented and interdisciplinary course that requires a background in mathematics, electrical circuits, control systems, analog and digital electronics, microprocessors, electric power, and electrical machines.

The understanding of the operation of a power electronics circuit requires a clear knowledge of the transient behavior of current and voltage waveforms for each and every circuit element at every instant of time.

These features make power electronics a difficult course for students to understand and for professors to teach. A laboratory helps in understanding power electronics and its control interfacing circuits. Development of a power electronics laboratory is relatively expensive compared to other courses in power electronics–electronic power (EE) curriculum. Power electronics is playing a key role in industrial power control.

The Engineering Accreditation Commission of the Accreditation Board for Engineering and Technology (EAC/ABET) requirements specify the computer integration and design content in the EE curriculum. To be competitive, a power electronics course should integrate a design content of approximately 50% and an extensive use of computer-aided analysis.

The student version of PSpice, which is available free to students, is ideal for classroom use and for assignments requiring computer-aided simulation and analysis. Without any additional resources and lecture time, PSpice can also be integrated into power electronics.

Probe is a graphics postprocessor in PSpice and is very useful in plotting the results of simulation. Especially with the capability of arithmetic operation, it can be used to plot impedance, power, etc. Once the students get experience in simulating on PSpice, they really appreciate the advantages of the .PROBE command. Probe is an option of PSpice, but it comes with the student version. Running Probe does not require a math coprocessor. Students can also opt for the normal printer output or printer plotting. The prints and plots are very helpful in relating students' theoretical understanding and making judgments on the merits of a circuit and its characteristics.

Probe is like a theoretical oscilloscope with the special features to perform arithmetic operations. It can be used as a laboratory bench to view the waveforms of currents, voltages, power, power factor, etc., with Fourier analysis giving the total harmonic distortion (THD) of any waveform.

The capability of Probe, along with other data representation features such as Table, Value, Function, Polynomial, Laplace, Param, and Step, makes PSpice

a versatile simulation tool for EE courses. Students can design power electronics circuits, use the PSpice simulator to verify the design, and make necessary design modifications. In the absence of a dedicated power electronics laboratory, the laboratory assignments could be design problems to be simulated and verified by PSpice.

This book is based on the author's experience in integrating 50% design content and SPICE on a power electronics course of 3 credit hours. The students were assigned design problems and asked to use PSpice to verify their designs by plotting or printing the output waveforms and to confirm the ratings of devices and components by plotting the instantaneous voltage, current, and power. The objective of this book is to integrate the SPICE simulator with a power electronics course at the junior level or senior level with a minimum amount of time and effort. This book assumes no prior knowledge about the SPICE simulator and introduces the applications of various SPICE commands through numerous examples of power electronics circuits.

This book can be divided into nine parts: (1) introduction to SPICE simulation — Chapter 1 to Chapter 3; (2) source and element modeling — Chapter 4 and Chapter 5; (3) SPICE commands — Chapter 6; (4) rectifiers — Chapter 7 and Chapter 11; (5) DC–DC converters — Chapter 8; (6) inverters — Chapter 9 and Chapter 10; (7) AC voltage controllers — Chapter 12; (8) control applications — Chapter 13 and Chapter 14; and (9) difficulties — Chapter 15. Chapter 7 to Chapter 12 use simple models for power semiconductor switches, leaving the complex models for special projects and assignments. Chapter 14 uses the simple circuit models of DC motors and AC inductor motors to predict their control characteristics. Two reference tables are included to aid in choosing a device, component, or command.

This book is intended to demonstrate the techniques for power conversions and the quality of the output waveforms, rather than the accurate modeling of power semiconductor devices. This approach has the advantage that the students can compare the results with those obtained in a classroom environment with simple switch models of devices.

This book can be used as a textbook on SPICE for students specializing in power electronics and power systems. It can also be a supplement to any standard textbook on power electronics and power systems. The following sequence is recommended:

1. Supplement to a basic power systems (or electrical machine) course with three hours of lectures (or equivalent lab hours) and self-study assignments from Chapter 1 to Chapter 6. Starting from Chapter 2, the students should work with PCs.
2. Continue as a supplement to a power electronics course with two hours of lectures (or equivalent lab hours) and self-study assignments from Chapter 7 to Chapter 14.

Without any prior experience on SPICE and integrating SPICE at the power electronics level, two hours of lectures (or equivalent lab hours) are recommended on [Chapter 1](#) to [Chapter 6](#). [Chapter 7](#) to [Chapter 14](#) could be left for self-study assignments. From the author's experience in the class, it has been observed that after two lectures of 50 min duration, all students could solve assignments independently without any difficulty. The class could progress in a normal manner with one assignment per week on power electronics circuits simulation and analysis with SPICE.

The book has sections on suggested laboratory experiments and design problems on power electronics. The complete laboratory guidelines for each experiment are presented. Thus, the book can also be used as a laboratory manual for power electronics. The design problems can be used as assignments for a design-oriented simulation laboratory.

Although the materials on this book have been developed for engineering students, the book is also strongly recommended for EET students specializing in power electronics, and power systems.

Any comments and suggestions regarding this book are welcomed and should be sent to the author.

Dr. Muhammad H. Rashid  
Professor and Director  
Electrical and Computer Engineering  
University of West Florida  
11000 University Parkway  
Pensacola, Florida 32514–5754,USA  
E-mail: [mrashid@uwf.edu](mailto:mrashid@uwf.edu)

**Muhammad H. Rashid**  
**Hasan M. Rashid**  
*Pensacola, Florida*

---

# The Authors

**Muhammad H. Rashid** is employed by the University of Florida as Professor of Electrical and Computer Engineering and Director of the UF/UWF Joint Program in Electrical and Computer Engineering. Dr. Rashid received a B.Sc. degree in Electrical Engineering from the Bangladesh University of Engineering and Technology, and M.Sc. and Ph.D. degrees from the University of Birmingham in the UK. Previously, he worked as Professor of Electrical Engineering and Chair of the Engineering Department at Indiana University-Purdue University Fort Wayne. He also worked as Visiting Assistant Professor of Electrical Engineering at the University of Connecticut, Associate Professor of Electrical Engineering at Concordia University (Montreal, Canada), Professor of Electrical Engineering at Purdue University Calumet, and Visiting Professor of Electrical Engineering at King Fahd University of Petroleum and Minerals (Saudi Arabia), as a design and development engineer with Brush Electrical Machines Ltd. (England, UK), a Research Engineer with Lucas Group Research Centre (England, UK), and a Lecturer and Head of Control Engineering Department at the Higher Institute of Electronics (Malta).

Dr. Rashid is actively involved in teaching, researching, and lecturing in power electronics. He has published 16 books and more than 130 technical papers. His books are adopted as textbooks all over the world. One of his books, titled *Power Electronics*, has translations in Spanish, Portuguese, Indonesian, Korean, and Persian. Another of his works, *Microelectronics*, has translations in Spanish in Mexico and Spain. He has had many invitations from foreign governments and agencies to be keynote lecturer and consultant, from foreign universities to serve as an external Ph.D. examiner, and from funding agencies to review research proposals. His contributions in education are recognized by foreign governments and agencies to lecture and consult (NATO for Turkey in 1994, UNDP for Bangladesh in 1989 and 1994, Saudi Arabia in 1993, Pakistan in 1993, Malaysia in 1995 and 2002, Bangkok in 2002), by foreign universities (in Australia, Canada, Hong Kong, India, Malaysia, Singapore) to serve as an external examiner (for undergraduate, master's and Ph.D. examinations), by funding agencies (in Australia, Canada, USA, Hong Kong) to review research proposals, and by U.S. and foreign universities to evaluate promotion cases for professorship.

Dr. Rashid has authored nine Prentice Hall books: *Power Electronics — Circuits, Devices and Applications* (1988, 2/e 1993, 2003, 3/e), *SPICE for Power Electronics* (1993), *SPICE for Circuits and Electronics Using PSpice* (1990, 2/e 1995, 2003, 3/e), *Electromechanical and Electrical Machinery* (1986), and

*Engineering Design for Electrical Engineers* (1990). He has also authored five IEEE self-study guides, *Self-Study Guide on Fundamentals of Power Electronics*, *Power Electronics Laboratory Using PSpice*, *Selected Readings on SPICE Simulation of Power Electronics*, and *Selected Readings on Power Electronics* (IEEE Press, 1996) and *Microelectronics Laboratory Using Electronics Workbench* (IEEE Press, 2000). In addition, he has authored two books, *Electronic Circuit Design using Electronics Workbench* (January 1998) and *Microelectronic Circuits — Analysis and Design* (April 1999) by PWS Publishing, and has edited *Power Electronics Handbook* published by Academic Press (2001).

Dr. Rashid is a registered Professional Engineer in the Province of Ontario (Canada), a registered Chartered Engineer (UK), a Fellow of the Institution of Electrical Engineers (IEE, UK) and a Fellow of the Institute of Electrical and Electronics Engineers (IEEE, USA). He was elected as an IEEE Fellow with the citation "*Leadership in power electronics education and contributions to the analysis and design methodologies of solid-state power converters.*" Dr. Rashid is the recipient of the 1991 Outstanding Engineer Award from The Institute of Electrical and Electronics Engineers (IEEE). He received the 2002 IEEE Educational Activity Award (EAB) Meritorious Achievement Award in Continuing Education with the citation "*for contributions to the design and delivery of continuing education in power electronics and computer-aided-simulation.*" Dr. Rashid was an ABET program evaluator for electrical engineering from 1995 to 2000 and he is currently an engineering evaluator for the Southern Association of Colleges and Schools (SACS, USA). He has been elected as an IEEE-Industry Applications Society (IAS) a Distinguished Lecturer and Speaker. He is the Series Editor for *Power Electronics and Applications*, and *Nanotechnology and Applications* with CRC Press. He is also Editor-in-Chief of the *Electric Power and Energy Series* with Elsevier Publishing.

**Hasan M. Rashid** is a graduate student and Teaching Assistant since 2003 in the Department of Electrical and Computer Engineering, University of Florida. He received his BS degree in electrical engineering with Highest Honors from the University of Florida. He was designated as a University Scholar for the UF Undergraduate Research Initiative and completed a research project titled "Synthetic Ripple Design for Buck Converter." He designed, built, and tested a feedback converter (with higher than 80% efficiency) and reported his research in a paper titled "Design of an Efficient Half-Bridge Converter." He also completed a group project titled "Electronic Nose Based on Micro Mechanical Cantilever Arrays."

Mr. Rashid was on the Dean's List every Fall and Spring semester in the College of Engineering. He is a Member of Tau Beta Pi Engineering Honors Society and an Anderson Scholar. He was a Florida Bright Futures Scholar, Top Florida Scholar, and Valedictorian of his high school class in 2000.

---

# Acknowledgments

We would like to thank the following reviewers for their comments and suggestions:

Frederick C. Brockhurst, Rose–Hulman Institute of Technology

A. P. Saki Meliopoulos, Georgia Institute of Technology

Peter Lauritzen, University of Washington

Saburo Matsusaki, TDK Corporation, Japan

It has been a great pleasure working with the editorial staff: Nora Konopka, Helena Redshaw, and B. J. Clark. Finally, we would like to thank our family for their love, patience, and understanding.

---

# PSpice Software and Program Files

The enclosed CD contains (a) the user-defined model library file `Rashid_SP2_MODEL.LIB` and (b) all PSpice circuit files (with an extension `.CIR`) in the folder `Rashid_SP2_AD Circuits`, PSpice Schematics (with an extension `.SCH`) in the folder `Rashid_SP2_PSpice_Schematics`, and OrCAD Capture files (with extensions `.OPJ` and `.DSN`) in the folder `Rashid_SP2_Orcad_Capture` for use with the book. PSpice Schematics and OrCAD Capture software can be obtained or downloaded from

Cadence Design Systems, Inc.  
2655 Seely Avenue  
San Jose, CA 95134

Websites: <http://www.cadence.com>  
<http://www.orcad.com>  
<http://www.pspice.com>  
<http://www.ema-eda.com>

## IMPORTANT NOTES

The PSpice circuit files (with an extension `.CIR`) are self-contained, and each file contains the necessary devices or component models. However, the PSpice Schematics files (with an extension `.SCH`) need the user-defined model library file `Rashid_SP23_MODEL.LIB`, which is included with the PSpice Schematic files and must be included from the Analysis menu of PSpice Schematics. Similarly, the OrCAD Capture files (with extensions `.OPJ` and `.DSN`) also need the user-defined model library file `Rashid_SP2_MODEL.LIB`, which is included with the OrCAD Schematic files and must be included from the PSpice Simulation settings menu of the OrCAD Capture. If these files are not included, the simulation will not run and errors will occur.

For importing PSpice Schematics files to OrCAD Capture files, OrCAD Capture will require specifying the location of the `msim_evl.ini` file. OrCAD Capture folder may not have the `msim_evl.ini` file, and you must find the location of that file in your computer. If you cannot locate the file, you can copy the `msim_evl.ini` file from the enclosed CD to your window folder `C:\WINNT` so that its location becomes `C:\WINNT\msim_evl.ini`.

---

# Table of Contents

<b>Chapter 1</b>	<b>Introduction.....</b>	<b>1</b>
1.1	Introduction.....	1
1.2	Descriptions of SPICE .....	2
1.3	Types of Spice .....	2
1.4	Types of Analysis .....	3
1.5	Limitations of PSpice.....	5
1.6	Descriptions of Simulation Software Tools .....	5
1.7	PSpice Platform.....	6
1.7.1	PSpice A/D .....	6
1.7.2	PSpice Schematics.....	7
1.7.3	OrCAD Capture.....	7
1.8	PSpice Schematics vs. OrCAD Capture .....	9
1.9	SPICE Resources.....	10
1.9.1	Web Sites with Free SPICE Models .....	10
1.9.2	Web Sites with SPICE Models .....	11
1.9.3	SPICE and Circuit Simulation Information Sites .....	11
1.9.4	Engineering Magazines with SPICE Articles .....	12
	Suggested Reading.....	12
<b>Chapter 2</b>	<b>Circuit Descriptions.....</b>	<b>15</b>
2.1	Introduction.....	15
2.2	Input Files.....	15
2.3	Nodes .....	17
2.4	Element Values .....	17
2.5	Circuit Elements .....	19
2.6	Element Models.....	20
2.7	Sources.....	21
2.8	Output Variables .....	22
2.9	Types of Analysis .....	24
2.10	PSpice Output Commands .....	26
2.11	Format of Circuit Files.....	28
2.12	Format of Output Files.....	29
2.13	Examples of PSpice Simulations .....	30
2.13	PSpice Schematics.....	41
2.13.1	PSpice Schematics Layout .....	41
2.13.2	PSpice A/D .....	43
2.13.3	Probe.....	43

2.14	Importing Microsim Schematics in OrCAD Capture.....	45
	Suggested Reading.....	50
	Problems.....	50
<b>Chapter 3</b>	<b>Defining Output Variables.....</b>	<b>53</b>
3.1	Introduction.....	53
3.2	DC Sweep and Transient Analysis.....	53
3.2.1	Voltage Output.....	53
3.2.2	Current Output.....	55
3.2.3	Power Output.....	56
3.3	AC Analysis.....	59
3.3.1	Voltage Output.....	59
3.3.2	Current Output.....	59
3.4	Output Markers.....	61
3.5	Noise Analysis.....	61
3.6	Summary.....	62
<b>Chapter 4</b>	<b>Voltage and Current Sources.....</b>	<b>65</b>
4.1	Introduction.....	65
4.2	Sources Modeling.....	65
4.2.1	Pulse Source.....	65
4.2.1.1	Typical Statements.....	67
4.2.2	Piecewise Linear Source.....	67
4.2.2.1	Typical Statement.....	68
4.2.3	Sinusoidal Source.....	68
4.2.3.1	Typical Statements.....	69
4.2.4	Exponential Source.....	70
4.2.4.1	Typical Statements.....	71
4.2.5	Single-Frequency Frequency Modulation Source.....	71
4.2.5.1	Typical Statements.....	72
4.3	Independent Sources.....	73
4.3.1	Independent Voltage Source.....	73
4.3.1.1	Typical Statements.....	74
4.3.2	Independent Current Source.....	74
4.3.2.1	Typical Statements.....	75
4.3.3	Schematic Independent Sources.....	75
4.4	Dependent Sources.....	75
4.4.1	Polynomial Source.....	75
4.4.1.1	Typical Model Statements.....	78
4.4.2	Voltage-Controlled Voltage Source.....	78
4.4.2.1	Typical Statements.....	79
4.4.3	Current-Controlled Current Source.....	79
4.4.3.1	Typical Statements.....	80

4.4.4	Voltage-Controlled Current Source.....	80
4.4.4.1	Typical Statements .....	80
4.4.5	Current-Controlled Voltage Source .....	81
4.4.5.1	Typical Statements .....	82
4.4.6	Schematic Dependent Sources .....	82
4.5	Behavioral Device Modeling.....	82
4.5.1	VALUE .....	84
4.5.1.1	Typical Statements .....	85
4.5.2	TABLE.....	86
4.5.2.1	Typical Statements .....	86
4.5.3	LAPLACE .....	87
4.5.3.1	Typical Statements .....	87
4.5.4	FREQ .....	87
4.5.4.1	Typical Statements .....	88
	Summary .....	88
	Suggested Reading.....	89
	Problems.....	90
<b>Chapter 5</b>	<b>Passive Elements .....</b>	<b>95</b>
5.1	Introduction.....	95
5.2	Modeling of Elements .....	95
5.2.1	Some Model Statements.....	97
5.3	Operating Temperature .....	98
5.3.1	Some Temperature Statements .....	98
5.4	RLC Elements .....	98
5.4.1	Resistor .....	98
5.4.1.1	Some Resistor Statements.....	101
5.4.2	Capacitor.....	101
5.4.2.1	Some Capacitor Statements .....	102
5.4.3	Inductor.....	102
5.4.3.1	Some Inductor Statements .....	104
5.5	Magnetic Elements and Transformers .....	106
5.5.1	Linear Magnetic Circuits.....	107
5.5.2	Nonlinear Magnetic Circuits .....	111
5.6	Lossless Transmission Lines .....	119
5.7	Switches.....	119
5.7.1	Voltage-Controlled Switch .....	121
5.7.2	Current-Controlled Switch .....	124
5.7.3	Time-Dependent Switches.....	127
5.7.3.1	Time-Dependent Close Switch .....	128
5.7.3.2	Time-Dependent Open Switch.....	128
	Summary .....	128
	Suggested Reading.....	131
	Problems.....	131

<b>Chapter 6</b>	<b>Dot Commands</b>	137
6.1	Introduction	137
6.2	Models	137
6.2.1	.MODEL (Model)	138
6.2.2	.SUBCKT (Subcircuit)	138
6.2.3	.ENDS (End of Subcircuit)	139
6.2.4	.FUNC (Function)	140
6.2.5	.GLOBAL (Global)	141
6.2.6	.LIB (Library File)	142
6.2.7	.INC (Include File)	143
6.2.8	.PARAM (Parameter)	144
6.2.9	.STEP (Parametric Analysis)	145
6.3	Types of Output	147
6.3.1	.PRINT (Print)	148
6.3.2	.PLOT (Plot)	148
6.3.3	.PROBE (Probe)	149
	Probe Statements	150
6.3.4	Probe Output	150
6.3.5	.WIDTH (Width)	154
6.4	Operating Temperature and End of Circuit	154
6.5	Options	155
6.6	DC Analysis	156
6.6.1	.OP (Operating Point)	158
6.6.2	.NODESET (Nodeset)	158
6.6.3	.SENS (Sensitivity Analysis)	159
6.6.4	.TF (Small-Signal Transfer Function)	162
6.6.5	.DC (DC Sweep)	165
6.7	AC Analysis	170
6.8	Noise Analysis	174
6.9	Transient Analysis	178
6.9.1	.IC (Initial Transient Conditions)	178
6.9.2	.TRAN (Transient Analysis)	179
6.10	Fourier Analysis	183
6.11	Monte Carlo Analysis	186
6.12	Sensitivity and Worst-Case Analysis	192
	Summary	195
	Suggested Reading	195
	Problems	196
<b>Chapter 7</b>	<b>Diode Rectifiers</b>	201
7.1	Introduction	201
7.2	Diode Model	201
7.3	Diode Statement	204

7.4	Diode Characteristics.....	204
7.5	Diode Parameters.....	206
	7.5.1 Modeling Zener Diodes.....	210
	7.5.2 Tabular Data .....	211
7.6	Diode Rectifiers.....	214
7.7	Laboratory Experiments .....	234
	7.7.1 Experiment DR.1.....	234
	Single-Phase Full-Wave Center-Tapped Rectifier.....	234
	7.7.2 Experiment DR.2.....	235
	Single-Phase Bridge Rectifier .....	235
	7.7.3 Experiment DR.3.....	236
	Three-Phase Bridge Rectifier .....	236
7.8	Summary.....	237
	Suggested Reading.....	237
	Design Problems .....	237

## **Chapter 8** DC–DC Converters.....241

8.1	Introduction.....	241
8.2	DC Switch Chopper .....	241
8.3	BJT SPICE Model.....	245
8.4	BJT Parameters.....	248
8.5	Examples of BJT Choppers .....	253
8.6	MOSFET Choppers .....	262
8.7	MOSFET Parameters.....	267
8.8	Examples of MOSFET Choppers .....	274
8.9	IGBT Model .....	276
8.10	Laboratory Experiment.....	281
	8.10.1 Experiment TP.1 .....	281
	DC Buck Chopper .....	281
	8.10.2 Experimental TP-2.....	283
	DC Boost Chopper .....	283
8.11	Summary.....	283
	Suggested Reading.....	284
	Design Problems .....	285

## **Chapter 9** Pulse-Width-Modulated Inverters.....289

9.1	Introduction.....	289
9.2	Voltage-Source Inverters .....	289
9.3	Current-Source Inverters .....	311
9.4	Laboratory Experiments .....	318
	9.4.1 Experiment PW.1.....	318
	Single-Phase Half-Bridge Inverter .....	318

9.4.2	Experiment PW.2.....	319
	Single-Phase Full-Bridge Inverter.....	319
9.4.3	Experiment PW.3.....	319
	Single-Phase Full-Bridge Inverter with PWM Control.....	319
9.4.4	Experiment PW.4.....	320
	Single-Phase Full-Bridge Inverter with SPWM Control.....	320
9.4.5	Experiment PW.5.....	320
	Three-Phase Bridge Inverter.....	320
9.4.6	Experiment PW.6.....	321
	Single-Phase Current-Source Inverter.....	321
9.4.7	Experiment PW.7.....	322
	Three-Phase Current-Source Inverter.....	322
	Summary.....	324
	Suggested Reading.....	324
	Design Problems.....	324
<b>Chapter 10 Resonant-Pulse Inverters.....</b>		<b>329</b>
10.1	Introduction.....	329
10.2	Resonant-Pulse Inverters.....	329
10.3	Zero-Current Switching Converters (ZCSC).....	336
10.4	Zero-Voltage Switching Converter (ZVSC).....	341
10.5	Laboratory Experiments.....	345
10.5.1	Experiment RI.1.....	345
	Single-Phase Half-Bridge Resonant Inverter.....	345
10.5.2	Experiment RI.2.....	346
	Single-Phase Full-Bridge Resonant Inverter.....	346
10.5.3	Experiment RI.3.....	347
	Push-Pull Inverter.....	347
10.5.4	Experiment RI.4.....	347
	Parallel Resonant Inverter.....	347
10.5.5	Experiment RI.5.....	348
	ZCSC.....	348
10.5.6	Experiment RI.6.....	349
	ZVSC.....	349
10.6	Summary.....	350
	Suggested Reading.....	350
	Design Problems.....	350
<b>Chapter 11 Controlled Rectifiers.....</b>		<b>355</b>
11.1	Introduction.....	355
11.2	AC Thyristor Model.....	355
11.3	Controlled Rectifiers.....	364
11.4	Examples of Controlled Rectifiers.....	364
11.5	Switched Thyristor DC Model.....	388

11.6	GTO Thyristor Model .....	389
11.7	Example of Forced-Commutated Rectifiers.....	389
11.8	Laboratory Experiments .....	402
11.8.1	Experiment TC.1 .....	403
	Single-Phase Half-Wave Controlled Rectifier .....	403
11.8.2	Experiment TC.2 .....	404
	Single-Phase Full-Wave Controlled Rectifier .....	404
11.8.3	Experiment TC.3 .....	405
	Three-Phase Full-Wave Controlled Rectifier .....	405
	Summary .....	405
	Suggested Reading.....	406
	Design Problems .....	406
<b>Chapter 12 AC Voltage Controllers .....</b>		<b>411</b>
12.1	Introduction.....	411
12.2	AC Thyristor Model .....	411
12.3	AC Voltage Controllers .....	412
12.4	Examples of AC Voltage Controllers .....	412
12.5	Laboratory Experiments .....	437
12.5.1	Experiment AC.1 .....	437
	Single-Phase AC Voltage Controller .....	437
12.5.2	Experiment AC.2 .....	439
	Three-Phase AC Voltage Controller .....	439
12.6	Summary.....	440
	Suggested Reading.....	440
	Design Problems .....	440
<b>Chapter 13 Control Applications.....</b>		<b>443</b>
13.1	Introduction.....	443
13.2	Op-Amp Circuits .....	443
13.2.1	DC Linear Models.....	444
13.2.2	AC Linear Models .....	444
13.2.3	Nonlinear Macromodels .....	445
13.3	Control Systems .....	456
13.4	Signal Conditioning.....	462
13.5	Closed-Loop Current Control .....	472
	Suggested Reading.....	480
	Problems.....	480
<b>Chapter 14 Characteristics of Electrical Motors.....</b>		<b>483</b>
14.1	Introduction.....	483
14.2	DC Motor Characteristics .....	483
14.3	Induction Motor Characteristics.....	490

Suggested Reading.....	494
Problems.....	495
<b>Chapter 15 Simulation Errors, Convergence Problems, and Other Difficulties</b> .....	497
15.1 Introduction.....	497
15.2 Large Circuits .....	497
15.3 Running Multiple Circuits.....	498
15.4 Large Outputs .....	498
15.5 Long Transient Runs .....	498
15.6 Convergence .....	499
15.6.1 DC Sweep.....	499
15.6.2 Bias-Point Calculation.....	501
15.6.3 Transient Analysis .....	504
15.7 Analysis Accuracy.....	505
15.8 Negative Component Values .....	506
15.9 Power Switching Circuits.....	507
15.9.1 Model Parameters of Diodes and Transistors.....	507
15.9.2 Error Tolerances .....	508
15.9.3 Snubbing Resistor.....	508
15.9.4 Quasi-Steady-State Condition .....	508
15.10 Floating Nodes .....	512
15.11 Nodes with Fewer than Two Connections .....	516
15.12 Voltage Source and Inductor Loops.....	517
15.13 Running PSpice Files on Spice.....	518
15.14 Running Spice Files on PSpice.....	518
15.15 Using Earlier Version of Schematics .....	519
Suggested Reading.....	520
Problems.....	520
<b>Appendix A Running PSpice on PCs</b> .....	523
A.1 Installing PSpice Software in PCs .....	523
A.2 Creating Input Circuit Files .....	524
A.3 Running DOS Commands.....	526
A.4 PSpice Default Symbol Libraries.....	528
<b>Bibliography</b> .....	531

---

# 1 Introduction

The learning objectives of this chapter are to develop an understanding of the following:

- General description and the types of SPICE software
- Types of analysis that can be performed on electronic and electrical circuits
- Limitations of PSpice software
- Online resources on SPICE

## 1.1 INTRODUCTION

Electronic circuit design requires accurate methods of evaluating circuit performance. Because of the enormous complexity of modern integrated circuits, computer-aided circuit analysis is essential and can provide information about circuit performance that is almost impossible to obtain with laboratory prototype measurements. Computer-aided analysis makes possible the following procedures:

1. Evaluation of the effects of variations in such elements as resistors, transistors, and transformers
2. Assessment of performance improvements or degradations
3. Evaluation of the effects of noise and signal distortion without the need for expensive measuring instruments
4. Sensitivity analysis to determine the permissible bounds determined by the tolerances of all element values or parameters of active elements
5. Fourier analysis without expensive wave analyzers
6. Evaluation of the effects of nonlinear elements on circuit performance
7. Optimization of the design of electronic circuits in terms of circuit parameters

SPICE (simulation program with integrated circuit emphasis) is a general-purpose circuit program that simulates electronic circuits. It can perform analyses on various aspects of electronic circuits, such as the operating (or quiescent) points of transistors, time-domain response, small-signal frequency response, and so on. SPICE contains models for common circuit elements, active as well as passive, and it is capable of simulating most electronic circuits. It is a versatile program and is widely used in both industry and academic institutions.

Until recently, SPICE was available only on mainframe computers. In addition to the cost of the computer system, such a machine can be inconvenient for classroom use. In 1984, MicroSim introduced the PSpice simulator, which is

similar to the Berkeley version of SPICE and runs on an IBM-PC or compatible, and is available free of cost to students for classroom use. PSpice® thus widens the scope for the integration of computer-aided circuit analysis into electronic circuits courses at the undergraduate level. Other versions of PSpice, which will run on the Macintosh II, 486-based processor, VAX, SUN, NEC, and other computers, are also available.

## 1.2 DESCRIPTIONS OF SPICE

PSpice is a member of the SPICE family of circuit simulators, all of which originate from the SPICE2 circuit simulator, whose development spans a period of about 30 yr. During the mid-1960s, the program ECAP was developed at IBM [1]. In the late 1960s, ECAP served as the starting point for the development of the program CANCER at the University of California (UC) at Berkeley. Using CANCER as the basis, SPICE was developed at Berkeley in the early 1970s. During the mid-1970s, SPICE2, which is an improved version of SPICE, was developed at UC–Berkeley. The algorithms of SPICE2 are robust, powerful, and general in nature, and SPICE2 has become an industry-standard tool for circuit simulation. SPICE3, a variation of SPICE2, is designed especially to support computer-aided design (CAD) research programs at UC–Berkeley. As the development of SPICE2 was supported using public funds, this software is in the public domain, which means that it may be used freely by all U.S. citizens.

SPICE2, referred to simply as SPICE, has become an industry standard. The input syntax for SPICE is a free-format style that does not require data to be entered in fixed column locations. SPICE assumes reasonable default values for unspecified circuit parameters. In addition, it performs a considerable amount of error checking to ensure that a circuit has been entered correctly.

PSpice, which uses the same algorithms as SPICE2, is equally useful for simulating all types of circuits in a wide range of applications. A circuit is described by statements stored in a file called the *circuit file*. The circuit file is read by the SPICE simulator. Each statement is self-contained and independent of every other statement, and does not interact with other statements. SPICE (or PSpice) statements are easy to learn and use.

A schematic editor can be used to draw the circuit and create a Schematics file, which can then be read by PSpice for running the simulation.

## 1.3 TYPES OF SPICE

The commercially supported versions of SPICE2 can be classified into two types: mainframe versions and PC-based versions. Their methods of computation may differ, but their features are almost identical. However, some may include such additions as a preprocessor or shell program to manage input and provide interactive control, as well as a postprocessor to refine the normal SPICE output. A person used to one SPICE version (e.g., PSpice) should be able to work with other versions.

Mainframe versions are:

HSPICE (from Meta-Software), which is for integrated-circuit design with special device models

RAD-SPICE (from Meta-Software), which simulates circuits subjected to ionizing radiation

IG-SPICE (from A.B. Associates), which is designed for “interactive” circuit simulation with graphics output

I-SPICE (from NCSS Time Sharing), which is designed for “interactive” circuit simulation with graphics output

Precise (from Electronic Engineering Software)

PSpice (from MicroSim)

AccuSim (from Mentor Graphics)

Spectre (from Cadence Design)

SPICE-Plus (from Valid Logic)

The PC versions include the following:

AllSpice (from Acotech)

Is-Spice (from Intusoft)

Z-SPICE (from Z-Tech)

SPICE-Plus (from Analog Design Tools)

DSPICE (from Daisy Systems)

PSpice (from MicroSim)

OrCAD (from Cadence)

Spice (from KEMET)

B2 Spice A/D (from Beige Bag Software)

AIM-Spice (from AIM-Software)

VisualSpice (from Island Logix)

Spice3f4 (from Kiva Design)

OrCAD SPICE (from OrCAD)

MDSPICE (from Zeland Software, Inc.)

Ivex Spice (from Ivex Design)

## 1.4 TYPES OF ANALYSIS

PSpice allows various types of analysis. Each analysis is invoked by including its command statement. For example, a statement beginning with the .DC command invokes the DC sweep. The types of analysis and their corresponding . dot commands are described in the following text.

DC analysis is used for circuits with time-invariant sources (e.g., steady-state DC sources). It calculates all node voltages and branch currents for a range of values, and their quiescent (DC) values are the outputs. The dot commands and their functions are:

- DC sweep of an input voltage or current source, a model parameter, or temperature over a range of values (.DC)
- Determination of the linearized model parameters of nonlinear devices (.OP)
- DC operating point to obtain all node voltages
- Small-signal transfer function with small-signal gain, input resistance, and output resistance (Thevenin’s equivalent; .TF)
- DC small-signal sensitivities (.SENS)

Transient analysis is used for circuits with time-variant sources (e.g., AC sources and switched DC sources). It calculates all node voltages and branch currents over a time interval, and their instantaneous values are the outputs. The dot commands and their functions are:

- Circuit behavior in response to time-varying sources (.TRAN)
- DC and Fourier components of the transient analysis results (.FOUR)

AC analysis is used for small-signal analysis of circuits with sources of variable frequencies. It calculates all node voltages and branch currents over a range of frequencies, and their magnitudes and phase angles are the outputs. The dot commands and their functions are:

- Circuit response over a range of source frequencies (.AC)
- Noise generation at an output node for every frequency (.NOISE)

In Schematics versions, the commands are invoked from the setup menu, as shown in Figure 1.1.

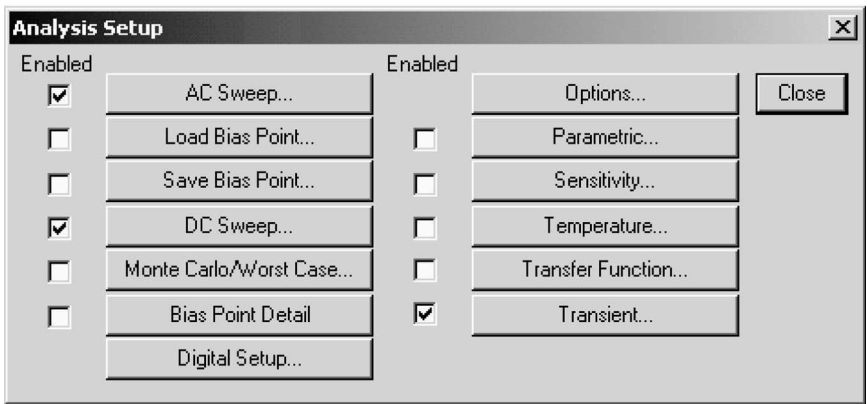


FIGURE 1.1 Analysis setup in PSpice Schematics versions.

## 1.5 LIMITATIONS OF PSpICE

As a circuit simulator, PSpice has the following limitations:

1. The PC-based student version of PSpice is restricted to circuits with 10 transistors only. However, the professional (or production) version can simulate a circuit with up to 200 bipolar transistors (or 150 MOSFETs).
2. The program is not interactive; that is, the circuit cannot be analyzed for various component values without editing the program statements.
3. PSpice does not support an iterative method of solution. If the elements of a circuit are specified, the output can be predicted. On the other hand, if the output is specified, PSpice cannot be used to synthesize the circuit elements.
4. The input impedance cannot be determined directly without running the graphic postprocessor, Probe. Although the student version does not require a floating-point coprocessor for running Probe, the professional version does.
5. To run the PC version requires 512 kilobytes of memory (RAM).
6. Distortion analysis is not available.
7. The output impedance of a circuit cannot be printed or plotted directly.
8. The student version can run with or without a floating-point coprocessor. If a coprocessor is present, the program will run at full speed. Otherwise, it will run 5 to 15 times slower. The professional version requires a coprocessor.

## 1.6 DESCRIPTIONS OF SIMULATION SOFTWARE TOOLS

There are many simulation software tools [1] in addition to SPICE; the following are some examples:

Automatic Integrated Circuit Modeling Spice (AIM-Spice) from AIM-Software is a new version of SPICE under the Microsoft Windows and Linux platforms.

AKNM Circuit Magic from Circuit Magic allows you to design, simulate, and learn about electrical circuits. It is an easy-to-use educational tool that allows simple DC and AC electrical circuits to be constructed and analyzed. The software allows circuit calculations using Kirchoff's laws, and node voltage and mesh current methods. It includes a schematic editor and vector diagram editor.

B2 Spice A/D 2000 from Beige Bag Software is a full-featured mixed-mode simulator that combines powerful capabilities with an interface that is deceptively easy to use.

Electronics Workbench Suite from Electronics Workbench is a professional circuit design solution with a suite of integrated tools that includes

schematic capture, simulation, layout, and autorouting for printed circuit boards (PCBs) and programmable logic devices such as FPGAs and CPLDs.

SPICE simulation, analog and mixed-signal circuit design, magnetics transformer design, and test program development tools are provided by Intusoft.

VisualSpice from Island Logix is a electronic circuit design and simulation software. It is a completely integrated, modern-user-interface circuit design environment that allows one to quickly and easily capture schematic designs, perform simulation, and analyze the results.

Ivex Design provides Windows-based EDA tools, schematic capture, SPICE tools, and PCB layout.

Schematic CAD software and EDA software include circuit simulation, schematic entry, PCB layout, and Gerber Viewer.

MacroSim Digital Simulator from Visionics is a sophisticated software tool that integrates the process of designing and simulating the operation of digital electronic circuitry. It has been developed for professional engineers, hobbyists, and tertiary and late-secondary students.

MDSPICE from Zeland Software is a mixed-frequency and time-domain SPICE simulator for predicting the time-domain response of high-speed networks, high-frequency circuits, and nonlinear devices directly using S-parameters.

Micro-Cap from Spectrum Software is an analog or digital simulation that is compatible with SPICE and PSpice.

NOVA-686 Linear RF Circuit Simulation is a shareware, RF circuit simulation program for the RF design engineer, radio amateur, and hobbyist.

SIMetrix from Catena Software is an affordable mixed-mode circuit simulator designed for professional circuit designers.

## 1.7 PSPICE PLATFORM

The platform depends on the SPICE version. There are three platforms for PSpice, as follows:

1. PSpice A/D or OrCAD PSpice A/D (version 9.1 or above)
2. PSpice Schematics (version 9.1 or below)
3. OrCAD Capture Lite (version 9.2 or above)

### 1.7.1 PSPICE A/D

The platform for PSpice A/D is shown in [Figure 1.2](#). A circuit described by statements and analysis commands is simulated by a run command from the platform. The output results can be displayed and viewed from platform menus.

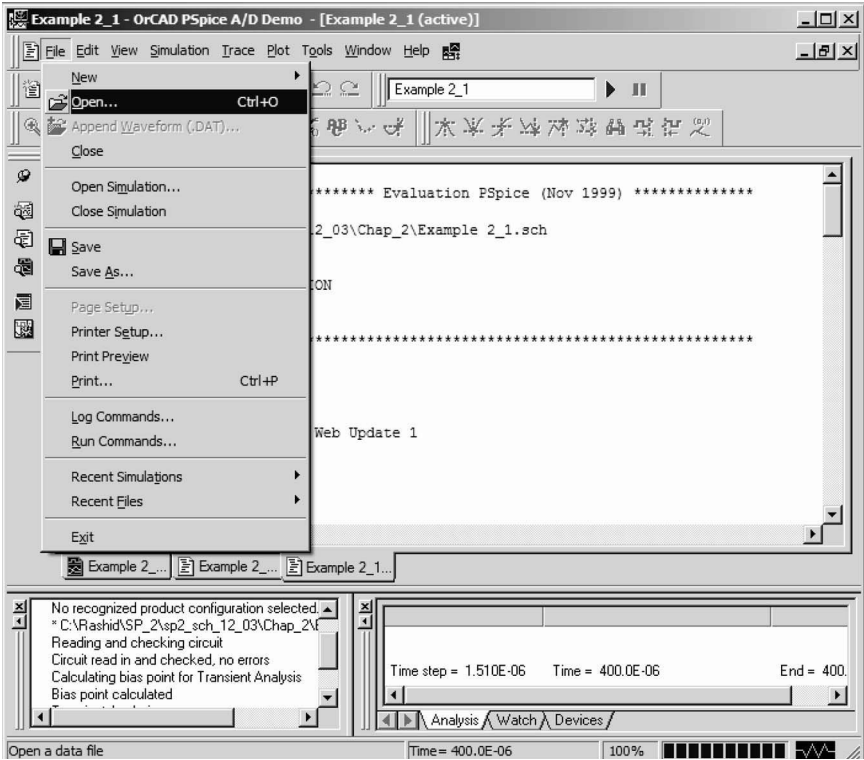


FIGURE 1.2 Platform for PSpice A/D (version 9.1).

### 1.7.2 PSpice SCHEMATICS

The platform for PSpice Schematics is shown in Figure 1.3. The circuit that is drawn on the platform is run from the analysis menu. The simulation type and settings are specified from the Analysis menu. After the simulation run is completed, PSpice automatically opens PSpice A/D for displaying and viewing the output results.

### 1.7.3 ORCAD CAPTURE

The platform for OrCAD Capture, which is similar to that of PSpice Schematics and has more features, is shown in Figure 1.4. The circuit that is drawn on the platform is run from the PSpice menu. The simulation type and settings are specified from the PSpice menu. After the simulation run is completed, Capture automatically opens PSpice A/D for displaying and viewing the output results.

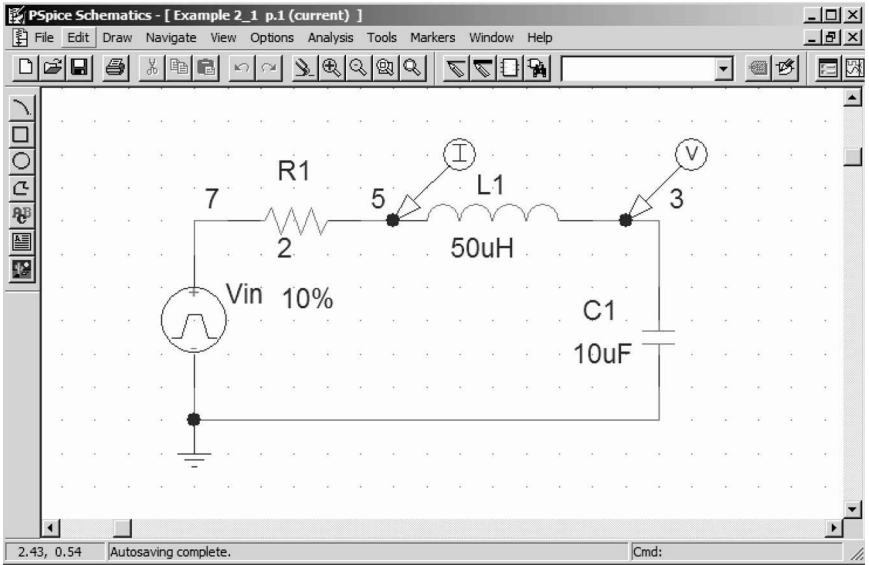


FIGURE 1.3 Platform for PSpice Schematics (version 9.1).

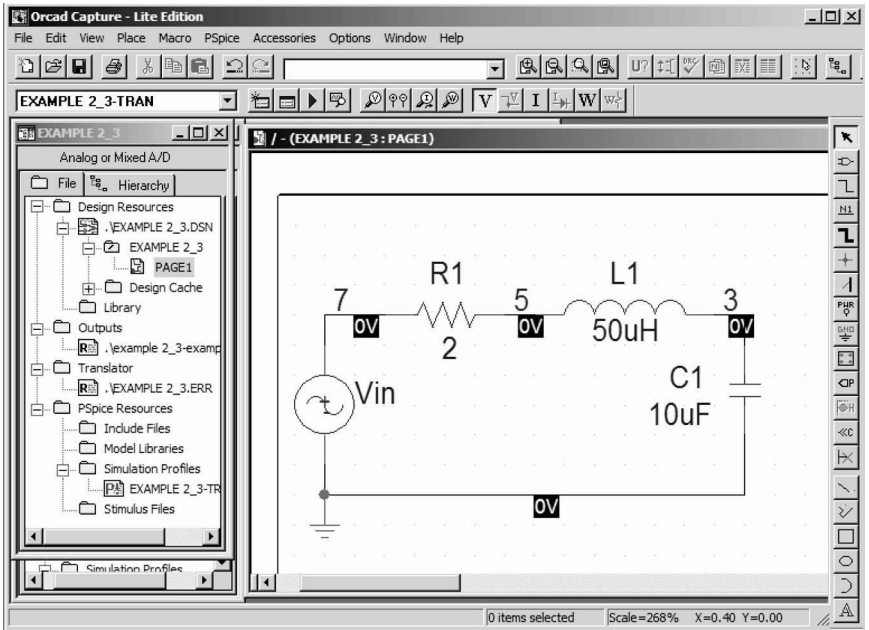
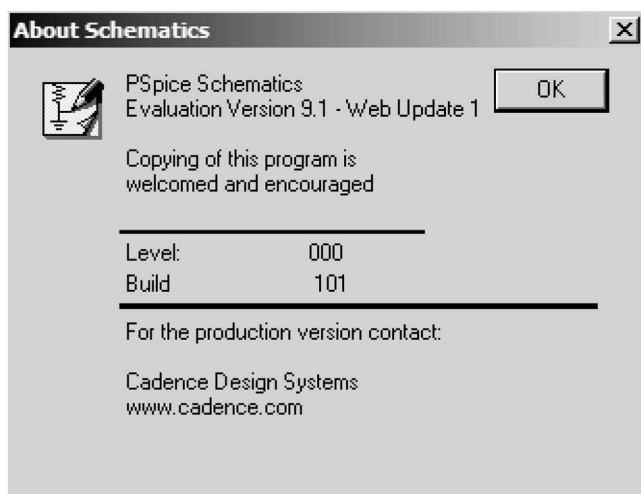


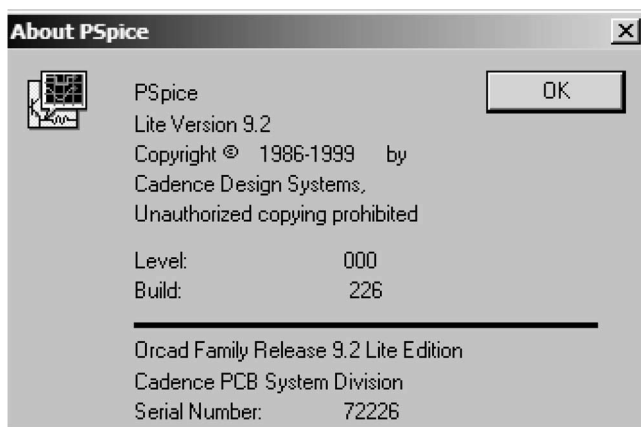
FIGURE 1.4 Platform for OrCAD Capture (version 9.1).

## 1.8 PSPICE SCHEMATICS VS. ORCAD CAPTURE

OrCAD Capture has some new features, and the platform is similar to that of PSpice Schematic. Schematics files (with extension .SCH) can be imported to OrCAD Capture (with extension .OPJ). However, OrCAD files cannot be run on PSpice Schematics. Therefore, it is advisable that those readers familiar with PSpice Schematics use PSpice Schematics version 9.1, which has a platform similar to that of version 8.0. However, its PSpice A/D is similar to that of OrCAD Capture. PSpice Schematics (version 9.1), as shown in Figure 1.5, can be downloaded from the Cadence Design Systems Web site <http://www.cadence.com>.



(a)



(b)

**FIGURE 1.5** About Schematics. (a) PSpice, (b) OrCAD.

## 1.9 SPICE RESOURCES

There are many online resources. Some of them are listed in the following subsections.

### 1.9.1 WEB SITES WITH FREE SPICE MODELS

Analog Devices

[http://products.analog.com/products\\_html/list\\_gen\\_spice.html](http://products.analog.com/products_html/list_gen_spice.html)

Apex Microtechnology

<http://eportal.apexmicrotech.com/mainsite/index.asp>

Coilcraft

<http://www.coilcraft.com/models.cfm>

Comlinear

<http://www.national.com/models>

Elantec

<http://www.elantec.com/pages/products.html>

Epcos Electronic Parts and Components

[http://www.epcos.de/web/home/html/home\\_d.html](http://www.epcos.de/web/home/html/home_d.html)

Fairchild Semiconductor Models and Simulation Tools

<http://www.fairchildsemi.com/models/>

Infineon Technologies AG

<http://www.infineon.com/>

Intersil Simulation Models

<http://www.intersil.com/design/simulationModels.asp>

International Rectifier

<http://www.irf.com/product-info/models/>

Johanson Technology

<http://www.johansontechnology.com/>

Linear Technology

<http://www.linear-tech.com/software/>

Maxim

<http://www.maxim-ic.com/>

Microchip

<http://www.microchip.com/index.asp>

Motorola Semiconductor Products

<http://www1.motorola.com/>

National Semiconductor

<http://www.national.com/models>

Philips Semiconductors

<http://www.semiconductors.philips.com/>

Polyfet

<http://www.polyfet.com/>

Teccor

<http://www.teccor.com/asp/sitemap.asp?group=downloads>

Texas Instruments

<http://www.ti.com/sc/docs/msp/tools/macromod.htm#comps>

Zetex

<http://www.zetex.com/>

### 1.9.2 WEB SITES WITH SPICE MODELS

Analog & RF Models

<http://www.home.earthlink.net/~wksands/>

Analog Innovations

<http://www.analog-innovations.com/>

Duncan's Amp Pages

<http://www.duncanamps.com/>

EDN Magazine

<http://www.e-insite.net/ednmag/>

Intusoft Free SPICE Models

<http://www.intusoft.com/models.htm>

MOSIS IC Design Models

<http://www.mosis.org/>

Planet EE

<http://www.planetee.com/>

PSpice.com

<http://www.pspice.com/>

SPICE Models from Symmetry

<http://www.symmetry.com/>

SPICE Model Index

<http://homepages.which.net/~paul.hills/Circuits/Spice/ModelIndex.html>

### 1.9.3 SPICE AND CIRCUIT SIMULATION INFORMATION SITES

AboutSpice.com

<http://www.aboutspice.com/>

Artech House Publishers — Books and Software for High-Technology Professionals

<http://www.artech-house.com/>

EDTN Home Page

<http://www.edtn.com/>

E/J Bloom Associates Home Page — SMPS Books & Software

<http://www.ejbloom.com/>

MOSIS IC Foundry

<http://www.mosis.org/>

NCSU SPICE Benchmarks

[http://www.cbl.ncsu.edu/pub/Benchmark\\_dirs/](http://www.cbl.ncsu.edu/pub/Benchmark_dirs/)

NIST Modeling Validation Group

<http://ray.eeel.nist.gov/modval.html>

Norman Koren Vacuum Tube Audio Page

<http://www.normankoren.com/Audio/>

PSpice.com

<http://www.pspice.com/>

Ridley Engineering PWM Simulation

<http://www.ridleyengineering.com/>

SGS-Thomson

<http://us.st.com/stonline/index.shtml>

SPICE Simulations Dr Vincent G Bello

<http://www.spicesim.com/>

SPICE Simulation One Trick Pony (Japanese)

Temic (Siliconix)

[http://www.temic.com/index\\_en.html?](http://www.temic.com/index_en.html?)

University of Exeter's Online SPICE3 User's Manual

<http://newton.ex.ac.uk/teaching/CDHW/Electronics2/userguide/>

Virtual Library Electrical Engineering

<http://webdiee.cem.itesm.mx/wwwvlee/>

Yahoo Club Circuit Simulation Chat Room

<http://login.yahoo.com/config/login?.intl=uk&.src=ygrp&.done=http://uk.groups.yahoo.com%2Fclubs%2Felectroniccircuitsimulation>

#### 1.9.4 ENGINEERING MAGAZINES WITH SPICE ARTICLES

EDN Home Page

<http://www.e-insite.net/ednmag/>

Electronic Design

<http://www.elecdesign.com/>

PCIM Home Page

<http://www.pcim.com/>

Personal Engineering & Instrumentation

<http://www.pcim.com/>

Planet EE

<http://www.planetee.com/>

### Suggested Reading

1. M.H. Rashid, *Introduction of PSpice Using Orcad for Circuits and Electronics*, Englewood Cliffs, NJ: Prentice-Hall, 2004.
2. M.H. Rashid, *SPICE for Power Electronics and Electric Power*, Englewood Cliffs, NJ: Prentice-Hall, 1995.
3. Edward Brumgnach, *PSpice for Windows*, New York: Delmar Publishers, 1995.
4. Roy W. Goody, *PSpice for Windows-A Circuit Simulation Primer*, Englewood Cliffs, NJ: Prentice-Hall, 1995.
5. Roy W. Goody, *PSpice for Windows Vol II: Operational Amplifiers and Digital Circuits*, Englewood Cliff, NJ: Prentice-Hall, 1996.

6. Roy W. Goody, *OrCAD PSpice for Windows Volume I: DC and AC Circuits*, Englewood Cliffs, NJ: Prentice-Hall, 2000.
7. Roy W. Goody, *OrCAD PSpice for Windows Volume II: Devices, Circuits, and Operational Amplifiers*, Englewood Cliffs, NJ: Prentice-Hall, 2000.
8. Marc E. Herniter, *Schematic Capture with Cadence PSpice*, Englewood Cliffs, NJ: Prentice-Hall, 2001.
9. John Keown, *PSpice and Circuit Analysis*, 3rd ed., New York: Merrill (Macmillan Publishing Company), 1997.
10. Paul G. Krol, *Inside Orcad Capture*, Clifton Park, NY: OnWord Press, 1998.
11. Robert Lamey, *The Illustrated Guide to PSpice for Windows*, New York: Delmar Publishers, 1995.
12. Yim-Shu Lee, *Computer-Aided Analysis and Design of Switch-Mode Power Supplies*. New York: Marcel Dekker, 1993.
13. Giuseppe Massobrio and Paolo Antognetti, *Semiconductor Device Modeling with SPICE*, 2nd ed., New York: McGraw-Hill, 1993.
14. Attia John Okyere, *PSPICE and MATLAB for Electronics: An Integrated Approach*, Boca Raton, FL: CRC Press, 2002.
15. T.E. Price, *Analog Electronics: An Integrated PSpice Approach*, Englewood Cliffs, NJ: Prentice-Hall, 1996.
16. R. Ramshaw and D. Schuurman, *PSpice Simulation of Power Electronics Circuits*, New York: Kluwer Academic Publishers, 1997.
17. Chris Schroeder, *Inside Orcad Capture for Windows*, Burlington, MA: Newnes, 1998.
18. Gordon W. Roberts and Adel S. Sedra, *SPICE*, New York: Oxford University Press, 1997.
19. John A. Stuller, *Basic Introduction to PSpice*, New York: John Wiley & Sons, 1995.
20. James A. Svoboda, *PSpice for Linear Circuits*, New York: John Wiley & Sons, 2002.
21. Paul Tuinenga, *SPICE: A Guide to Circuit Simulation and Analysis Using PSpice*, 3rd ed., Englewood Cliffs, NJ: Prentice-Hall, 1995.

---

# 2 Circuit Descriptions

The learning objectives of this chapter are:

- Describing circuits for PSpice simulation
- Creating input files that can be read by PSpice
- Obtaining output results and plots of simulations
- Performing PSpice simulation for finding the transient plots and total harmonic distortion (THD) of voltages and currents

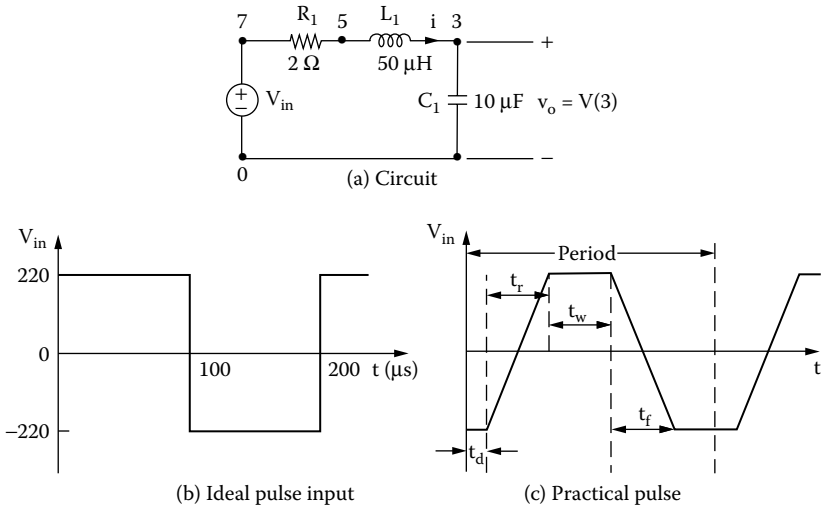
## 2.1 INTRODUCTION

PSpice is a general-purpose circuit program that can be applied to simulate electronic and electrical circuits. A circuit must be specified in terms of element names, element values, nodes, variable parameters, and sources. The input to the circuit shown in Figure 2.1(a) is a pulse voltage as shown in Figure 2.1(b). The circuit is to be simulated for calculating and plotting the transient response from 0 to 400  $\mu\text{sec}$  with an increment of 1  $\mu\text{sec}$ . The Fourier series coefficients and THD are to be printed. We discuss how to (1) describe this circuit to PSpice, (2) specify the type of analysis to be performed, and (3) define the output variables required. Description and analysis of a circuit require that the following be specified:

- Input files
- Nodes
- Element values
- Circuit elements
- Element models
- Sources
- Output variables
- Types of analysis
- PSpice output commands
- Format of circuit files
- Format of output files

## 2.2 INPUT FILES

The input to the SPICE simulation can be either a Schematics file or a net-list file (also known as the *circuit file*). In a circuit file, the user assigns the node numbers to the circuit as shown in Figure 2.1(a). The ideal and practical pulses



**FIGURE 2.1** RLC circuit with pulse input. (a) Circuit, (b) ideal pulse input, (c) practical pulse.

are shown in Figure 2.1(b) and Figure 2.1(c). The nodes connect the circuit elements, the semiconductor devices, and the sources. If a resistor  $R$  is connected between two nodes 7 and 5, SPICE relates the voltage  $v_R$  across  $R$  and the current  $i$  through  $R$  by

$$v_R = V(7) - V(5) = R i$$

where the current  $i$  flows from node 7 to 5. If an inductor  $L$  is connected between two nodes 5 and 3, SPICE relates the voltage  $v_L$  across  $L$  and the current  $i$  through  $L$  by

$$v_L = V(5) - V(3) = L \frac{di}{dt}$$

where the current  $i$  flows from node 5 to 3. If a capacitor  $C$  is connected between two nodes 3 and 0, SPICE relates the voltage  $v_C$  across  $C$ , and the current  $i$  through  $C$  by

$$v_C = V(3) - V(0) = \frac{1}{C} \int i dt + v_C(t = 0)$$

where the current  $i$  flows from node 3 to 0,  $v_C(t = 0)$  is the initial condition (or voltage) at  $t = 0$ , and  $V(0) = 0$  is the ground potential.

From these descriptions of the circuit elements in the form of a net list, SPICE develops a set of matrices and solves for all voltages and currents for specified input sources. The circuit file can be simulated by PSpice A/D. Table 2.1 shows

**TABLE 2.1**  
**Names and Functions of Programs within PSpice**

Program Name	Program Function
Schematics	Schematic circuit entry, symbol editor, and design management
PSpice A/D	Mixed analog and digital circuit simulation
Probe	Presentation and postprocessing of simulation results
Stimulus Editor	Graphic creation of input signals

the names and functions of programs within PSpice. Probe is a graphical post-processor for displaying output variables such as voltages, currents, powers, and impedances.

For a schematic input file, PSpice Schematics creates the net list automatically. Once the descriptions of the circuit and the type of analysis are specified, PSpice Schematics can simulate the schematic file and then solve for all voltages and currents.

## 2.3 NODES

**For PSpice A/D:** Node numbers, which must be integers from 0 to 9999 but need not be sequential, are assigned to the circuit of [Figure 2.1\(a\)](#). Elements are connected between nodes. The node numbers are specified after the name of the element connected to the node. Node 0 is predefined as the ground. All nodes must be connected to at least two elements and should therefore appear at least twice. All nodes must have a DC path to the ground node. This condition, which is not met in all circuits, is normally satisfied by connecting very large resistors (see [Section 15.10](#)).

**For PSpice Schematics:** Node numbers are assigned by PSpice and are usually alphanumeric such as \$N\_0005 and \$N\_0003, as listed in the following table:

First Node	Second Node
\$N_0005	\$N_0003
0	+
-	out
\$N_0003	-
0	out

## 2.4 ELEMENT VALUES

The value of a circuit element is written after the nodes to which the element is connected. The values are written in standard floating-point notation with optional

scale and units suffixes. Some values without suffixes that are allowed by PSpice are

```
55. 5.0 5E+3 5.0E+3 5.E3
```

There are two types of suffixes: the scale suffix and the units suffix. The scale suffixes multiply the numbers that they follow. Scale suffixes recognized by PSpice are:

F	1E-15
P	1E-12
N	1E-9
U	1E-6
MIL	25.4E-6
M	1E-3
K	1E3
MEG	1E6
G	1E9
T	1E12

The units suffixes that are normally used are:

V	volt
A	ampere
HZ	hertz
OHM	ohm
H	henry
F	farad
DEG	degree

The first suffix is always the scale suffix; the units suffix follows the scale suffix. In the absence of a scale suffix, the first suffix may be a units suffix provided it is not a symbol of a scale suffix. The units suffixes are always ignored by PSpice. If the value of an inductor is 15  $\mu\text{H}$ , it is written as 15U or 15UH. In the absence of scale and units suffixes, the units of voltage, current, frequency, inductance, capacitance, and angle are by default volts, amperes, hertz, henrys, farads, and degrees, respectively. PSpice ignores any units suffix, and the following values are equivalent:

```
25E-3 25.0E-3 25M 25MA 25MV 25MOHM 25MH
```

Note the following:

1. The scale suffixes are all uppercase letters.
2. M means “milli,” not “mega.” 2  $\text{M}\Omega$  is written as 2MEG or 2MEGOHM.

---

**TABLE 2.2**  
**Symbols of Circuit Elements and Sources**

First Letter	Circuit Elements and Sources
B	GaAs MES field-effect transistor
C	Capacitor
D	Diode
E	Voltage-controlled voltage source
F	Current-controlled current source
G	Voltage-controlled current source
H	Current-controlled voltage source
I	Independent current source
J	Junction field-effect transistor
K	Mutual inductors (transformer)
L	Inductor
M	MOS field-effect transistor
Q	Bipolar junction transistor
R	Resistor
S	Voltage-controlled switch <sup>a</sup>
T	Transmission line
V	Independent voltage source
W	Current-controlled switch <sup>a</sup>

<sup>a</sup> Not available in SPICE2 but available in SPICE3.

---

## 2.5 CIRCUIT ELEMENTS

**For PSpice A/D:** Circuit elements are identified by name. A name must start with a letter symbol corresponding to the element, but after that it can contain either letters or numbers. Names can be up to eight characters long. Table 2.2 shows the first letter of elements and sources. For example, the name of a capacitor must start with a C.

The format for describing passive elements is

```
<element name> <positive node> <negative node> <value>
```

where the current is assumed to flow from the positive node N+ to the negative node N-. The formats for passive elements are described in [Chapter 5](#). The passive elements of [Figure 2.1\(a\)](#) are described as follows:

The statement that  $R_1$  has a value of  $2\ \Omega$  and is connected between nodes 7 and 5 is

```
R1 7 5 2
```

The statement that  $L_1$  has a value of  $50\ \mu\text{H}$  and is connected between nodes 5 and 3 is

$L_1$  5 3 50UH

The statement that  $C_1$  has a value of 10  $\mu\text{F}$  and is connected between nodes 3 and 0 is

$C_1$  3 0 10UF

**For PSpice Schematics:** The name of an element begins with a specific letter, as shown in Table 2.2. The part symbols can be obtained from the Place menu as shown in Figure 2.2(a). The symbols for passive elements are obtained from the analog.slb library as shown in Figure 2.2(b). The element name as shown in Figure 2.3(a) and its value can be changed within the schematic as shown in Figure 2.3(b). The net list is created by PSpice automatically, and a typical listing is shown in the following table:

Element Name	First Node	Second Node	Value
R_R1	\$N_0002	\$N_0001	2
R_Rx	0	+	1 k
R_RF	-	out	5 k
C_C1	\$N_0001	-	10 $\mu\text{F}$
R_RL	0	out	20 k

## 2.6 ELEMENT MODELS

The values of some circuit elements are dependent on other parameters; for example, the inductance of an inductor depends on the initial conditions, the capacitance on voltage, and the resistance on temperature. Models may be used to assign values to the various parameters of circuit elements. The techniques for specifying models of sources, passive elements, and dot commands are described in Chapter 4, Chapter 5, and Chapter 6, respectively.

We shall represent the source voltage by a pulse, which has a model of the form

PULSE(-VS +VS TD TR TF PW PER)

where

- VS, +VS = negative and positive values of the pulse, respectively,
- TD, TR, TF = delay time, rise time, and fall time, respectively,
- PW = width of the pulse, and
- PER = period of the pulse.

In practice, it is not possible to generate a pulse with a zero value for the TD and TF. Thus, TR and TF should have small but finite values. A practical pulse is shown in Figure 2.1(c). Let us assume that TD = 0 and TR = TF = 1 nsec. The model for the input voltage of Figure 2.1(b) becomes

PULSE (-220V +220V 0 1NS 1NS 100US 200US)

Place	Macro	Accessories	Options
Part...			Shift+P
Wire			Shift+W
Bus			Shift+B
Junction			Shift+J
Bus Entry			Shift+E
Net Alias...			Shift+N
Power...			Shift+F
Ground...			Shift+G
Off-Page Connector...			
Hierarchical Block...			
Hierarchical Port...			
Hierarchical Pin...			
No Connect			Shift+X
Title Block...			
Bookmark...			
Text...			Shift+T
Line			
Rectangle			
Ellipse			
Arc			
Polyline			Shift+Y
Picture...			

(a)

**FIGURE 2.2** Place and Part menus from the analog.slb library file. (a) Place menu for getting parts, (b) symbols from analog.slb library file.

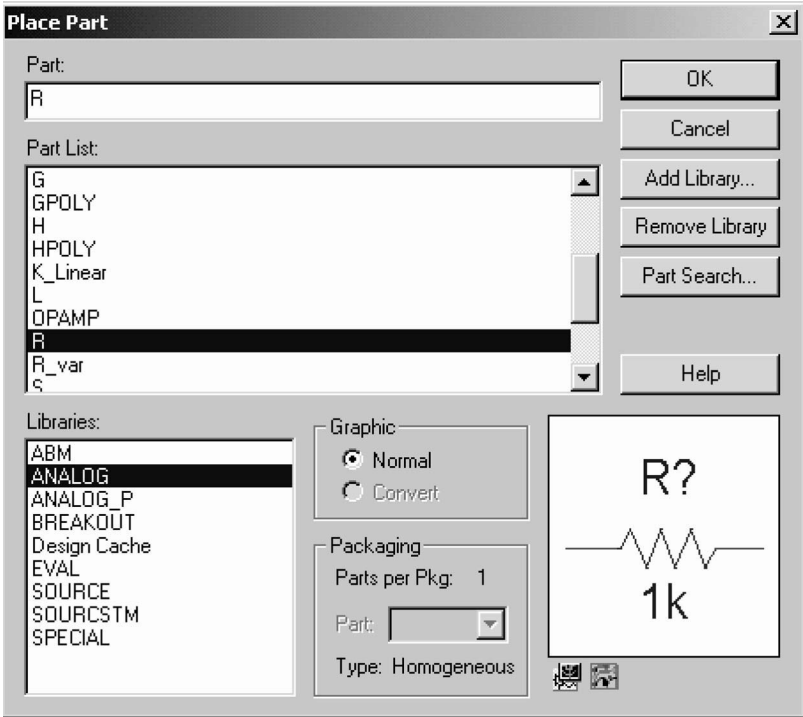
**For PSpice Schematics:** Model parameters are often specifications of the sources, as shown in [Figure 2.4\(a\)](#) for a pulse voltage. The values can be changed from the Display Properties menu as shown in [Figure 2.4\(b\)](#).

## 2.7 SOURCES

**For PSpice A/D:** Voltage (or current) sources can be either dependent or independent. Also listed in [Table 2.2](#) are the letter symbols for the types of sources. An independent voltage (or current) source can be DC, sinusoidal, pulse, exponential, polynomial, piecewise linear, or single-frequency frequency modulation. Models for describing source parameters are discussed in [Chapter 4](#).

The format for a source is

```
<source name> <positive node> <negative node> <source model>
```



(b)

**FIGURE 2.2** (continued).

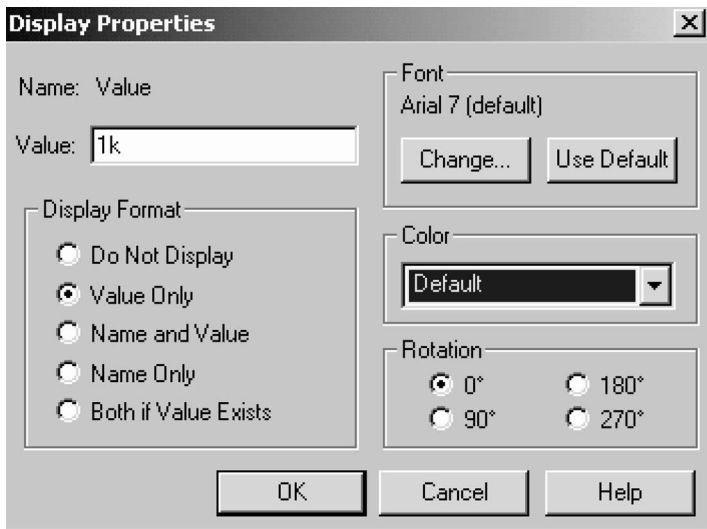
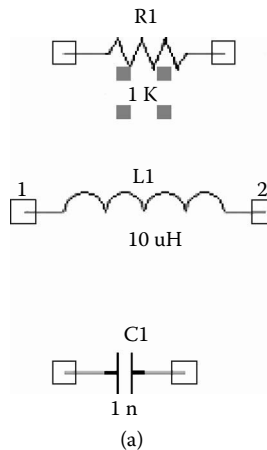
where the current is assumed to flow into the source from positive node  $N+$  to negative node  $N-$ . The order of nodes  $N+$  and  $N-$  is critical. Assuming that node 7 has a higher potential than node 0, the statement for the input source  $v_{in}$  connected between nodes 7 and 0 is

```
VIN 7 0 PULSE (-220V +220V 0 1NS 1NS 100US 200US)
```

**For PSpice Schematics:** The name of a source with the specified letter is shown in [Table 2.2](#). The source symbols for voltages and current can be obtained from the source.slb library as shown in [Figure 2.5](#).

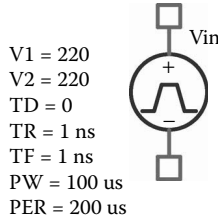
## 2.8 OUTPUT VARIABLES

**For PSpice A/D:** PSpice has some unique features for printing and plotting output voltages and currents. The various types of output variables permitted by PSpice are discussed in [Chapter 3](#). For example, the voltage of node 3 with respect to node 0 is specified by  $V(3, 0)$  or  $V(3)$ .

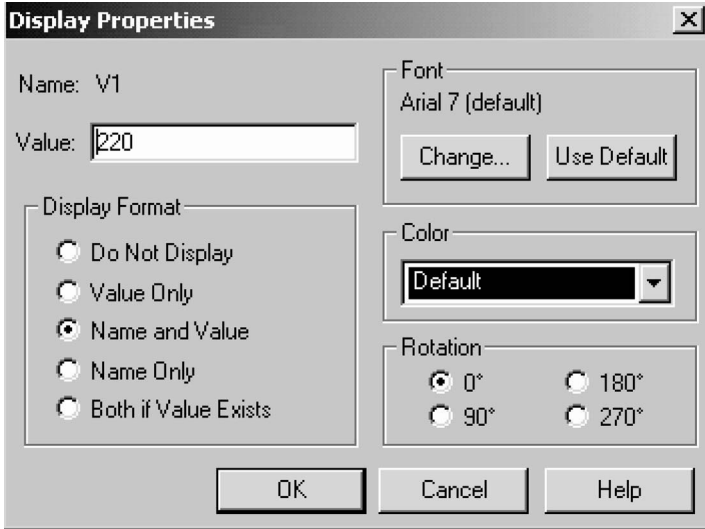


**FIGURE 2.3** Symbols and names of typical elements. (a) Symbols, (b) display properties.

**For PSpice Schematics:** PSpice assigns the node numbers. Thus, the user does not know the node numbers and, hence, cannot refer the output voltages to the node numbers. Instead, the output voltage is referred to one of two terminals of an element. For examples, the output voltage at the terminal 1 of a resistor R1 is specified by  $V(R1:1)$ , at the terminal 2 by  $V(R1:2)$ , and between terminals 1 and 2 by  $V(R1:1,R1:2)$ .



(a)



(b)

**FIGURE 2.4** Model parameters of a pulse voltage. (a) Pulse parameters, (b) display properties.

## 2.9 TYPES OF ANALYSIS

**For PSpice A/D:** PSpice allows various types of analysis. Each type is invoked by including its command statement. For example, a statement beginning with a .DC command will cause a DC sweep to be carried out. The types of analysis and their corresponding dot commands are:

### DC analysis

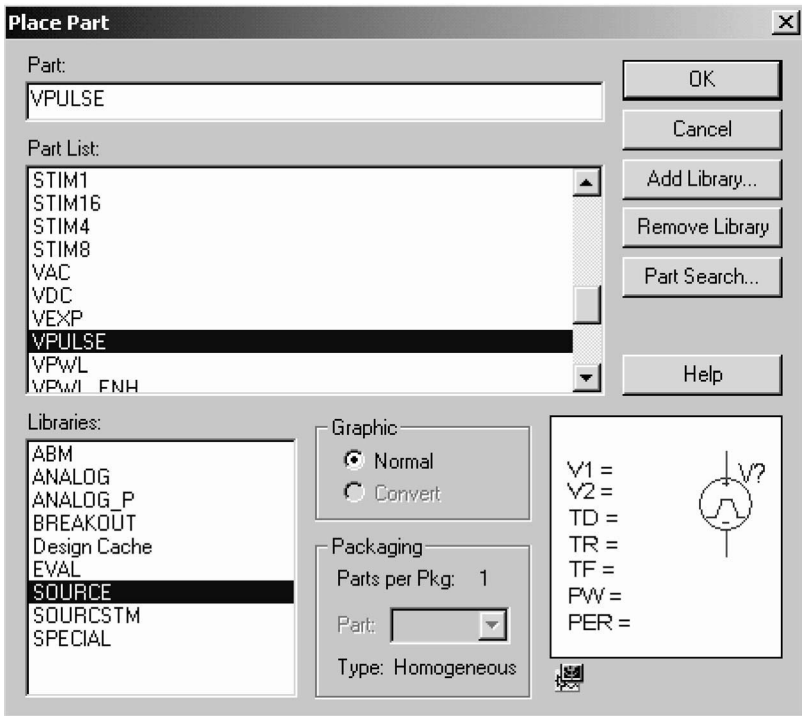
DC sweep of an input voltage or current source, a model parameter, or temperature (.DC)

Linearized device model parameterization (.OP)

DC operating point (.OP)

Small-signal transfer function (Thévenin's equivalent; .TF)

Small-signal sensitivities (.SENS)



**FIGURE 2.5** Sources from the source.slb library.

### Transient analysis

Time-domain response (.TRAN)

Fourier analysis (.FOUR)

### AC analysis

Small-signal frequency response (.AC)

Noise analysis (.NOISE)

It should be noted that the dot is an integral part of a command. The various dot commands are discussed in detail in [Chapter 6](#).

The format for performing a transient response is

```
.TRAN TSTEP TSTOP
```

where TSTEP is the time increment and TSTOP is the final (stop) time. Therefore, the statement for the transient response from 0 to 400  $\mu\text{sec}$  with a 1- $\mu\text{sec}$  increment is

```
.TRAN 1US 400US
```

PSpice performs a Fourier analysis from the results of the transient analysis. The command for the Fourier analysis of voltage V(N) is

```
.FOUR FREQ VN
```

where FREQ is the fundamental frequency. Thus, the duration of the transient analysis must be at least one period. Here,  $PERIOD = 1/FREQ$ . The command for the Fourier analysis of voltage V(3) with  $PERIOD = 200 \mu\text{sec}$  and  $FREQ = 1/200 \mu\text{sec} = 5 \text{ kHz}$  is

```
.FOUR 5KHZ V(3)
```

**For PSpice Schematics:** The type of analysis to be performed on a circuit is chosen from the Simulation Settings menu (shown in [Figure 2.6\(b\)](#)) within the Edit Simulation Profile menu (shown in [Figure 2.6\(a\)](#)).

## 2.10 PSPICE OUTPUT COMMANDS

The most common forms of output are print tables and plots. The transient response (.TRAN), DC sweep (.DC), frequency response (.AC), and noise analysis (.NOISE) can produce output in the form of print tables and plots. The command for output in the form of tables is .PRINT, that for output plots is .PLOT, and that for graphical output is

```
.PROBE
```

The statement for the plots of V(3) and V(7) from the results of transient analysis is

```
.PLOT TRAN V(3)V(7)
```

The statement for the tables of V(3) and V(7) from the results of transient analysis is

```
.PRINT TRAN V(3)V(7)
```

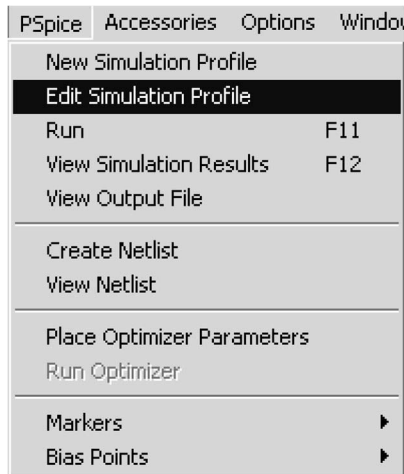
The output of .PRINT and .PLOT commands are stored in an output file created automatically by PSpice.

Probe is the graphics postprocessor of PSpice, and the statement for this command is

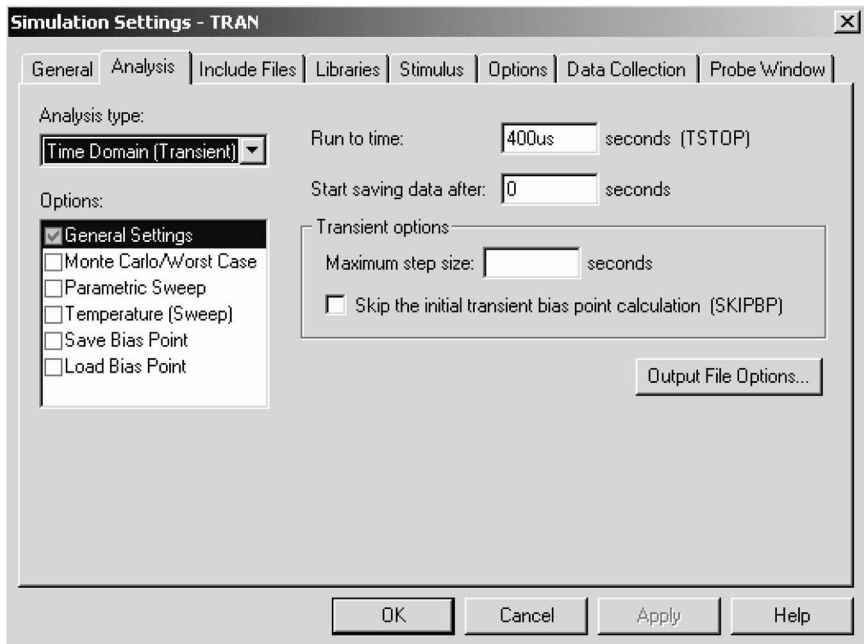
```
.PROBE
```

This causes the results of a simulation to be available in the form of graphical outputs on the display and also as hard copy. After executing the .PROBE command, Probe will display a menu on the screen to obtain graphical output. It is very easy to use Probe: With the .PROBE command, there is no need for the .PLOT command. .PLOT generates the plot on the output file, whereas .PROBE gives graphical output on the monitor screen, which can be dumped directly to a plotter or printer. The output commands are discussed in Section 6.3.

Probe is normally used for graphical outputs, instead of the print command.



(a)



(b)

**FIGURE 2.6** Analysis Settings menu. (a) Edit Simulation Profile menu, (b) selecting the analysis type: Transient Analysis.

## 2.11 FORMAT OF CIRCUIT FILES

**For PSpice A/D:** A circuit file that is read by PSpice may be divided into five parts: (1) the title, which describes the type of circuit, or any comments, (2) the circuit description, which defines the circuit elements and the set of model parameters, (3) the analysis description, which defines the type of analysis, (4) the output description, which defines the way the output is to be presented, and (5) the end of program. Therefore, the format for a circuit file is as follows:

Title  
 Circuit description  
 Analysis description  
 Output description  
 End-of-file statement (.END)

Note the following:

1. The first line is the title line, and it may contain any type of text.
2. The last line must be the .END command.
3. The order of the intervening lines is not important and does not affect the results of the simulation.
4. If a PSpice statement is longer than one line, it can be continued in the next line. A continuation line is identified by a plus sign (+) in the first column of the next line. The continuation lines must follow one another in the proper order.
5. A comment line may be included anywhere and should be preceded by an asterisk (\*).
6. The number of blanks between items is not significant (except for the title line). Tabs and commas are equivalent to blanks. For example, “ ” and “ ” and “ , ” and “ , ” are all equivalent.
7. PSpice statements or comments can be in either upper- or lowercase letters.
8. SPICE2 statements must be in uppercase letters. It is advisable to type the PSpice statements in uppercase so that the same circuit file can be run on SPICE2 also.
9. If you are not sure of a command or statement, use that command or statement to run the circuit file and see what happens. SPICE is user-friendly software that provides an error message on the output file.
10. In electrical circuits, subscripts are normally assigned to symbols for voltages, currents, and circuit elements. However, in SPICE, the symbols are represented without subscripts. For example,  $v_s$ ,  $i_s$ ,  $L_1$ ,  $C_1$ , and  $R_1$  are represented by VS, IS, L1, C1, and R1, respectively. As a result, the SPICE circuit description of voltages, currents, and circuit elements is often different from that in terms of the circuit symbols.

The menu for PSpice A/D is shown in [Figure 2.7](#). A new circuit file can be created, or an existing file can be opened by using the PSpice File menu, shown

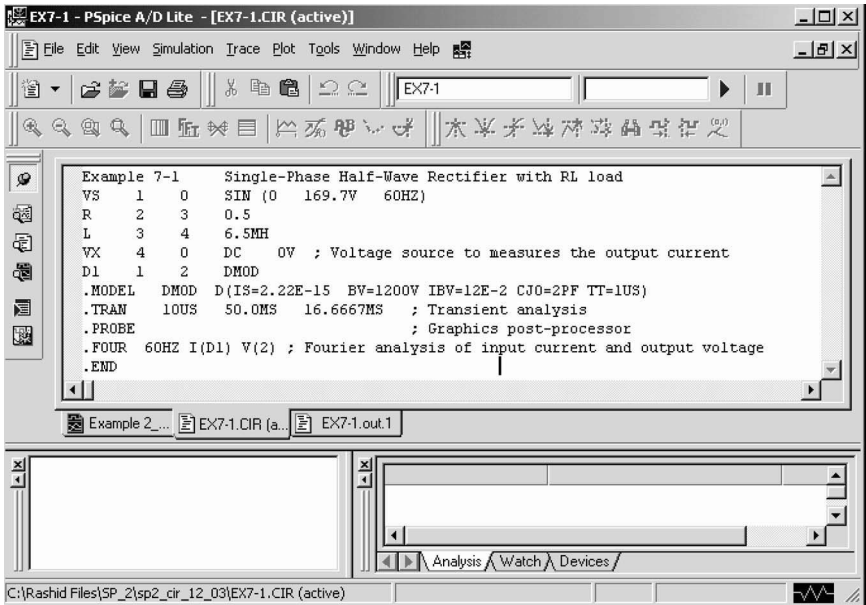


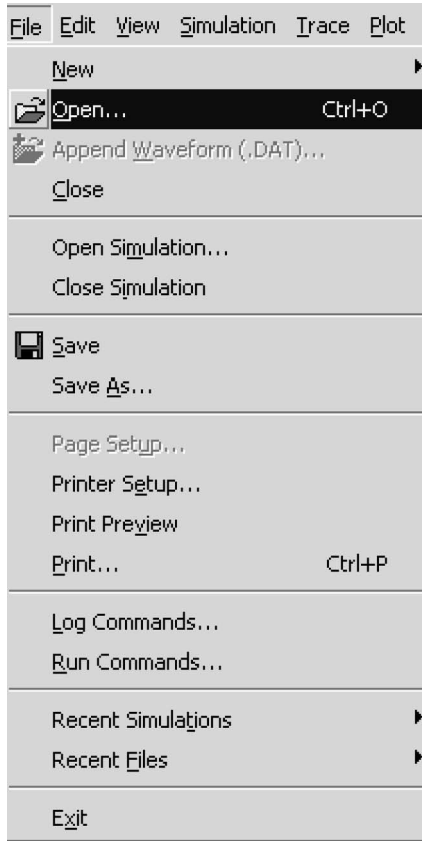
FIGURE 2.7 The PSpice A/D menu.

in Figure 2.8(a). The file can also be created by using any text file editor (e.g., Notepad or a word processor). The circuit file can be run from the PSpice Simulation menu, shown in Figure 2.8(b). The output file can be viewed from the PSpice View menu, shown in Figure 2.8(c), and the graphical plot can be viewed by selecting Simulation Results from the View menu, shown in Figure 2.8(b).

## 2.12 FORMAT OF OUTPUT FILES

The results of a simulation by PSpice are stored in an output file. It is possible to control the type and amount of output by various commands. PSpice will indicate any error in the circuit file by displaying a message on the screen and will suggest looking at the output file for details. The output is of four types:

1. A description of the circuit that includes the net list, the device list, the model parameter list, and so on.
2. Direct output from some of the analyses without the .PLOT and .PRINT commands. This includes the output from the .OP, .TF, .SENS, .NOISE, and .FOUR analyses.
3. Prints and plots resulting from .PRINT and .PLOT commands, including output from the .DC, .AC, and .TRAN analyses.
4. Run statistics, which includes various types of summary information about the entire run, including times required by various analyses and the amount of memory used.



(a)

**FIGURE 2.8** Submenus of the PSpice A/D. (a) File menu, (b) View menu, (c) Simulation menu.

## 2.13 EXAMPLES OF PSPICE SIMULATIONS

We have discussed the details of describing the circuit in [Figure 2.1\(a\)](#) as a PSpice input file. We will illustrate PSpice simulation by four examples.

### EXAMPLE 2.1 TRANSIENT PULSE RESPONSE OF AN *RLC* CIRCUIT

The *RLC* circuit of [Figure 2.1\(a\)](#) is to be simulated on PSpice to calculate and plot the transient response from 0 to 400  $\mu\text{sec}$  with an increment of 1  $\mu\text{sec}$ . The capacitor voltage,  $V(3)$ , and the current through  $R_1$ ,  $I(R1)$ , are to be plotted. The Fourier series coefficients and THD are to be printed. The circuit file's name is EX2.1.CIR, and the outputs are to be stored in the file EX2.1.OUT. The .PROBE command will make the results available both in display form and as hard copy.



FIGURE 2.8 (continued).

**SOLUTION**

The PSpice schematic is shown in Figure 2.9(a). The voltage and current markers display the output waveforms in Probe at the end of the simulation. The input voltage is specified by a pulse source as shown in Figure 2.9(b). The Transient Analysis is set at the Analysis Setup menu as shown in Figure 2.9(c), and its specifications are set at the Transient menu as shown in Figure 2.9(d). The circuit file contains the following statements:

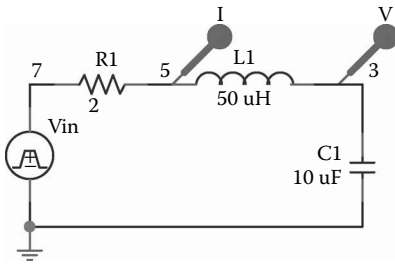
**Example 2.1 Pulse response of an RLC circuit**

- SOURCE** ■ \* The format for a pulse source is  
 \* PULSE (-V<sub>s</sub> +V<sub>s</sub> TD TR TF PW PER)  
 \* Refer to Chapter 4 for modeling sources.  
 \* v<sub>in</sub> is connected between nodes 7 and 0, assuming  
 that node 7  
 \* is at a higher potential than node 0.  
 \* For -220 to +220 V, a delay of t<sub>d</sub> = 0, a rise time  
 of t<sub>r</sub> = 1 nsec,  
 \* a fall time of t<sub>f</sub> = 1 nsec, a pulse width =  
 100 μsec, and  
 \* a period = 200 μsec, the source is described by

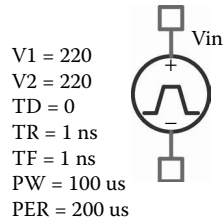
```

VIN 7 0 PULSE (-220V 200V 0 1NS 1NS 100US 200US)
CIRCUIT ■■ * R1, with a value of 2 Ω, is connected between nodes
7 and 5.
* Assuming that current flows into R1 from node 7 to
node 5 and that
* the voltage of node 7 with respect to node 5,
V(7, 5), is positive,
* R1 is described by
R1 7 5 2
* L1, with a value of 50 μH, is connected between
nodes 5 and 3.
* Assuming that current flows into L1 from node 5 to
node 3 and that
* the voltage of node 5 with respect to node 3,
V(5, 3), is positive,
* L1 is described by
L1 5 3 50UH
* C1, with a value of 10 μF, is connected between
nodes 3 and 0.
* Assuming that current flows into C1 from node 3 to
node 0 and that
* the voltage of node 3 with respect to node 0, V(3),
is positive,
* C1 is described by
C1 3 0 10UF
ANALYSIS ■■■ * Transient analysis is invoked by the .TRAN command,
whose simple format is
.TRAN TSTEP TSTOP
* Refer to Chapter 6 for dot commands. For transient
analysis
* from 0 to 400 μsec with an increment of 1 μsec,
the statement is
.TRAN 1US 400US
* The following statement prints the results of
transient analysis for V(R1), V(L1), and V(C1):
.PRINT TRAN V(R1) V(L1) V(C1)
* The following statement plots the results of
transient analysis for V(3) and I(R1):
.PLOT TRAN V(3)I(R1)
* Refer to Chapter 6 for dot commands. For Fourier
analysis
* of V(3) at a fundamental frequency of 5 kHz, the
statement is
.FOUR 5KHZ V(3)
* Graphic output can be obtained simply by invoking
the .PROBE command
* (refer to Chapter 6 for dot commands):
.PROBE
* The end of program is invoked by the .END command:
.END

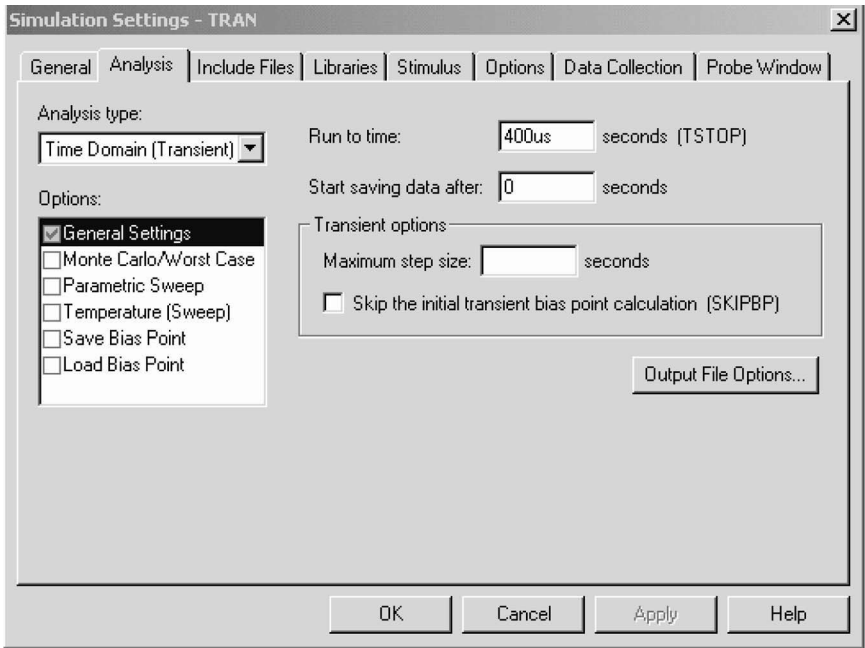
```



(a)



(b)



(c)

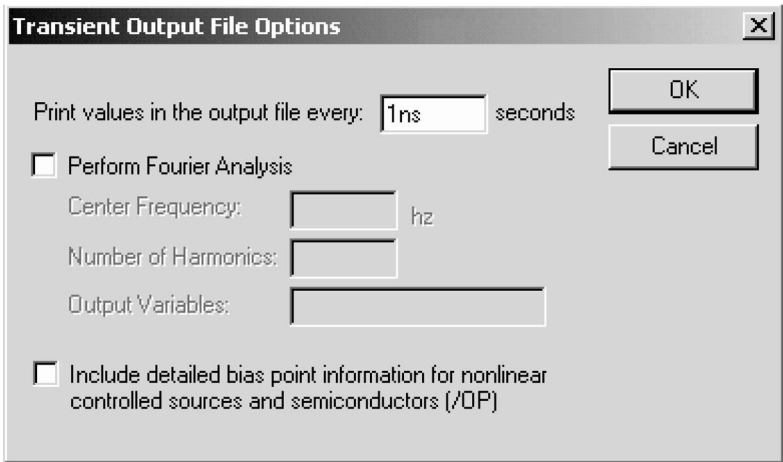
**FIGURE 2.9** PSpice schematic for Example 2.1. (a) PSpice schematic, (b) specifications of pulse voltage, (c) analysis and runtime setup, (d) transient output options.

If the PSpice programs are loaded in a fixed (hard) disk and the circuit file is stored in a floppy diskette on drive A:, the general command to run the circuit file is

```
PSPICE A: <input file> A: <output file>
```

For an input file EX2.1.CIR and the output file EX2.1.OUT, the command is

```
PSPICE A:EX2.1.CIR A:EX2.1.OUT
```



(d)

FIGURE 2.9 (continued).

If the output file's name is omitted, the results are stored by default on an output file that has the same name as the input file and is in the same drive, but with an extension .OUT. It is a good practice to have .CIR and .OUT extensions on circuit files so that the circuit file and the corresponding output file can be identified. Thus, the command can simply be

```
PSPICE A:EX2.1.CIR
```

The results of the transient response that are obtained on the display by the .PROBE command are shown in Figure 2.10. The results of the .PRINT statement can be obtained by printing the contents of the output file EX2.1.OUT. From this output file the results of the Fourier analysis are as follows:

---

### Fourier Components of Transient Response V(3)

DC COMPONENT =  $-1.726830E-01$

Harmonic No	Frequency (Hz)	Fourier Component	Normalized Component	Phase (Deg)	Normalized Phase (Deg)
1	5.000E+03	3.502E+02	1.000E+00	-5.171E+01	0.000E+00
2	1.000E+04	2.718E-01	7.762E-04	-1.795E+02	-1.278E+02
3	1.500E+04	2.245E+01	6.410E-02	-1.517E+02	-1.000E+02
4	2.000E+04	8.506E-02	2.429E-04	1.708E+02	2.225E+02
5	2.500E+04	4.411E+00	1.259E-02	-1.601E+02	-1.084E+02
6	3.000E+04	5.024E-02	1.435E-04	1.753E+02	2.270E+02
7	3.500E+04	1.683E+00	4.806E-03	-1.595E+02	-1.078E+02
8	4.000E+04	3.617E-02	1.033E-04	1.791E+02	2.309E+02
9	4.500E+04	8.936E-01	2.552E-03	-1.608E+02	-1.090E+02

TOTAL HARMONIC DISTORTION = 6.555345E+00 PERCENT

---

Example 2.1 Pulse response of a RLC-circuit

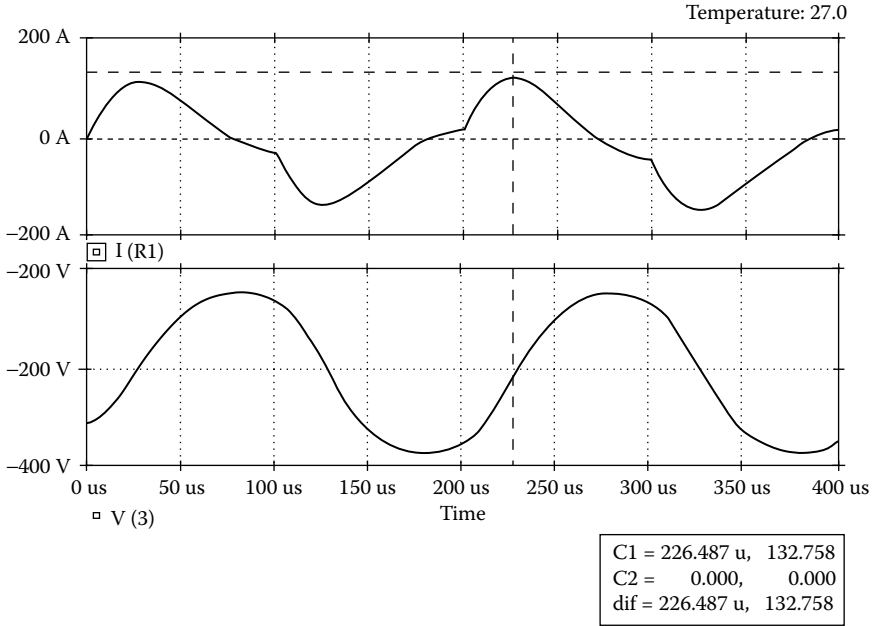


FIGURE 2.10 Pulse response for Example 2.1.

**EXAMPLE 2.2 EFFECT OF RESISTORS ON THE TRANSIENT PULSE RESPONSE OF AN RLC CIRCUIT**

Three RLC circuits with  $R = 2 \Omega$ ,  $1 \Omega$ , and  $8 \Omega$  are shown in Figure 2.11(a). The inputs are identical step voltages, as shown in Figure 2.11(b). Using PSpice the transient response from 0 to 400  $\mu\text{sec}$  with an increment of 1  $\mu\text{sec}$  is to be calculated and plotted. The capacitor voltages are the outputs V(3), V(6), and V(9), which are to be plotted. The circuit is to be stored in the file EX2.1.CIR, and the outputs are to be stored in the file EX2.2.OUT. The results should also be available for display and as hard copy, using the .PROBE command.

**SOLUTION**

The PSpice schematic is shown in Figure 2.12. The voltage and current markers display the output waveforms in Probe at the end of the simulation. The input voltages are specified by three pulse sources that are similar to that in Figure 2.9(b). Transient Analysis is set at the Analysis Setup menu as shown in Figure 2.9(c), and its specifications are set at the Transient menu as shown in Figure 2.9(d).

The description of the circuit file is similar to that of Example 2.1, except that the input is a step voltage rather than a pulse voltage. The circuit may be regarded as three RLC circuits having three separate inputs. The step signal can be represented by a piecewise linear source, and it is described in general by

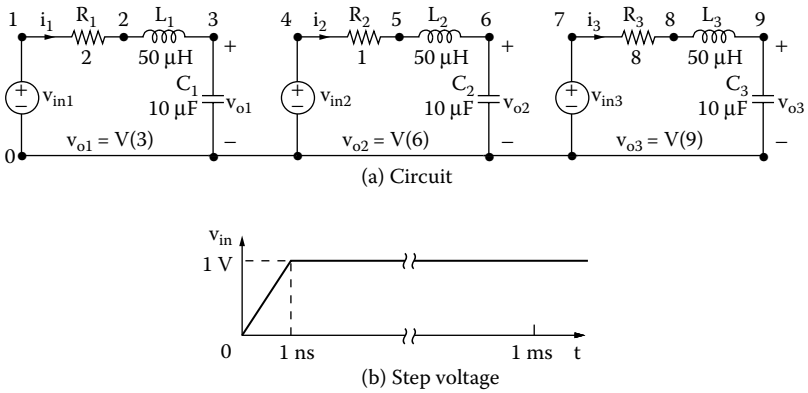


FIGURE 2.11 (a) RLC circuits, (b) step-pulse input voltages.

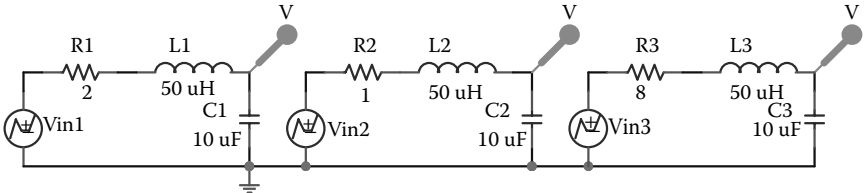


FIGURE 2.12 PSpice schematic for Example 2.2

PWL (T1 V1 T2 V2 ... TNVN)

where VN is the voltage at time TN. Assuming a rise time of 1 nsec, the step voltage of Figure 2.11(b) can be described by

PWL(0 0 1NS 1V 1MS 1V)

The listing of the circuit file is as follows:

The results of the transient analysis that are obtained on the display by the .PROBE command are shown in Figure 2.13. The results of the .PRINT statement can be obtained by printing the contents of the output file EX2.2.OUT.

**EXAMPLE 2.3 TRANSIENT RESPONSE OF AN RLC CIRCUIT WITH A SINUSOIDAL INPUT VOLTAGE**

Example 2.1 may be repeated with the input voltage as a sine wave of  $v_{in} = 10 \sin(2\pi \times 5000t)$ .

**Example 2.2 Step response of series RLC circuits**

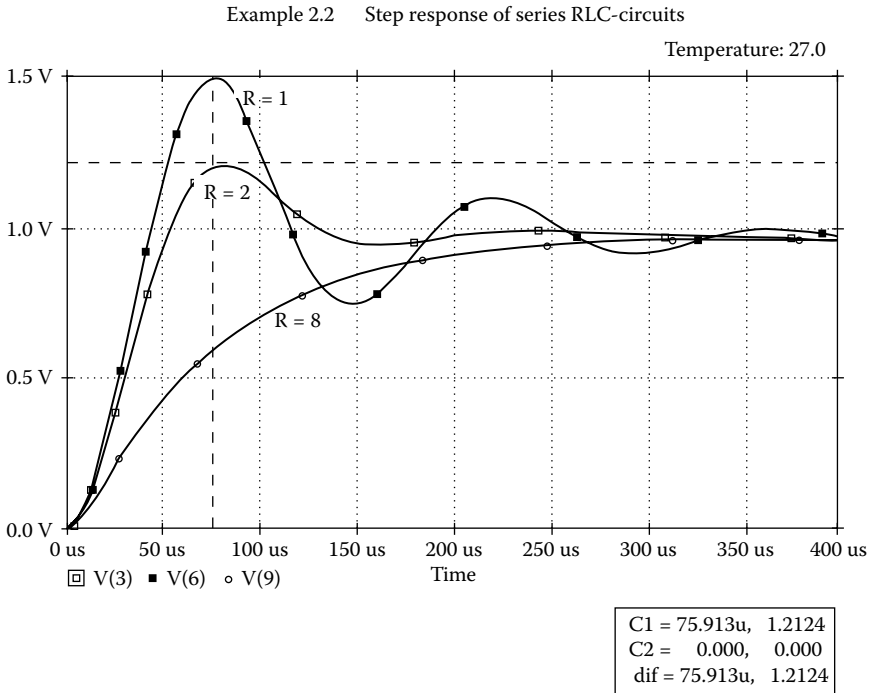
```

SOURCE   ■ V11 1 0 PWL (0 0 1NS 1V 1MS 1V) ; Step of 1 V
             V12 4 0 PWL (0 0 1NS 1V 1MS 1V) ; Step of 1 V
             V13 7 0 PWL (0 0 1NS 1V 1MS 1V) ; Step of 1 V

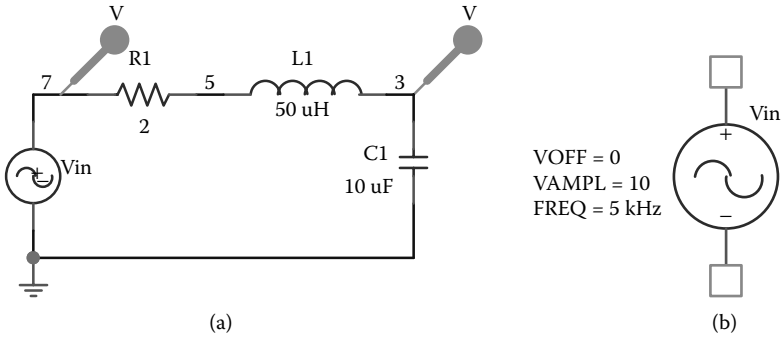
CIRCUIT  ■■ R1 1 2 2
              L1 2 3 50UH
              C1 3 0 10UF
              R2 4 5 1
              L2 5 6 50UH
              C2 6 0 10UF
              R3 7 8 8
              L3 8 9 50UH
              C3 9 0 10UF

ANALYSIS ■■■ .PLOT TRAN V(3) V(6) V(9) ; Plot output voltages
                .TRAN 1US 400US          ; Transient analysis
                .PROBE                    ; Graphics post-processor

                .END
    
```



**FIGURE 2.13** Step response of *RLC* circuits for Example 2.2.



**FIGURE 2.14** PSpice schematic for Example 2.3: (a) PSpice schematic, (b) specifications of sinusoidal source.

### SOLUTION

The PSpice schematic is shown in Figure 2.14(a). The voltage and current markers display the output waveforms in Probe at the end of the simulation. The input voltage is specified by a sinusoidal source as shown in Figure 2.14(b). The transient analysis is set at the Analysis Setup menu as shown in Figure 2.9(c), and its specifications are set at the transient menu as shown in Figure 2.9(d).

The model for a simple sinusoidal source is

```
SIN(VO VA FREQ)
```

where

VO = offset voltage, V

VA = peak voltage, V

FREQ = frequency, Hz

For a sinusoidal voltage  $v_{in} = 10 \sin(2\pi \times 5000t)$ , the model is

```
SIN(0 10V 5KHZ)
```

The circuit file contains the following statements:

---

### Example 2.3 RLC circuit with sinusoidal input voltage

- SOURCE** ■ \* The format for a simple sinusoidal source is  
 \* SIN(VO VA FREQ)  
 \* Refer to Chapter 4 for modeling sources.  
 \*  $v_{in}$  is connected between nodes 7 and 0, assuming that node 7  
 \* is at a higher potential than node 0.  
 \* With a peak voltage of  $V_A = 10$  V, a frequency = 5 kHz, and

\* an offset value of  $V_o = 0$ , the source is described by  
 VIN 7 0 SIN (0 10V 5KHZ) ; Input voltage

```
CIRCUIT ■■■ R1 7 5 2
              L1 5 3 50UH
              C1 3 0 10UF
```

```
ANALYSIS ■■■ .PLOT TRAN V(3) V(7) ; Plot output voltages
                .TRAN 1US 500US ; Transient analysis
                .PROBE ; Graphics post-processor
                .END
```

Example 2.3 A RLC-circuit with a sinusoidal input voltage

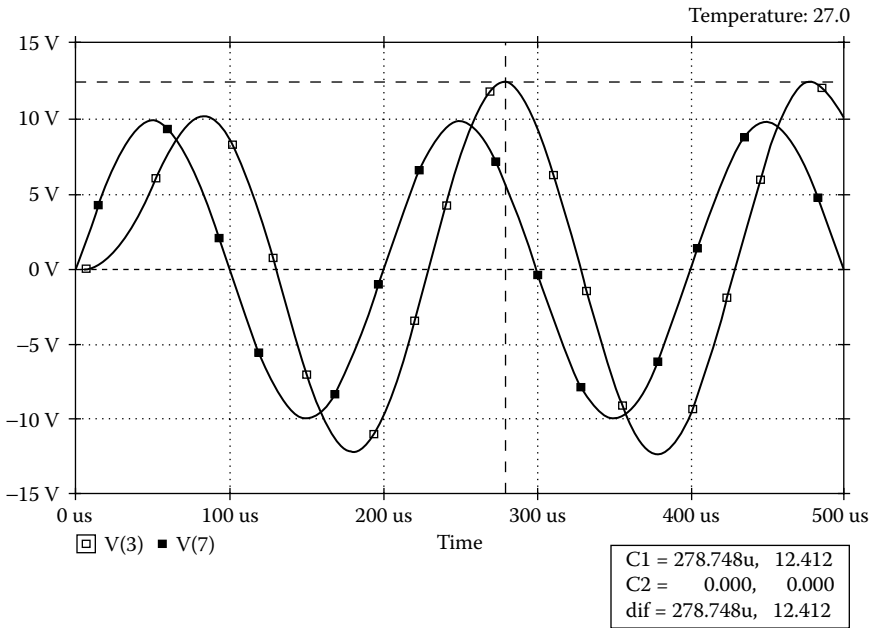


FIGURE 2.15 Transient response for Example 2.3.

The results of the transient response that are obtained on the display by the .PROBE command are shown in Figure 2.15. The results of the .PRINT statement can be obtained by printing the contents of the output file EX2.3.OUT.

**EXAMPLE 2.4 FINDING THE FREQUENCY RESPONSE OF AN RLC CIRCUIT**

For the circuit of Figure 2.11(a), the frequency response is to be calculated and printed over the frequency range 100 to 100 kHz with a decade increment and 100 points per decade. The peak magnitude and phase angle of the voltage across the capacitors are to be plotted on the output file. The results should also be available for display and as hard copy, using the .PROBE command.

**SOLUTION**

The input voltage is AC, and its frequency is variable. We will consider a voltage source with a peak magnitude of 1 V. The PSpice schematic is shown in [Figure 2.16\(a\)](#). The voltage and current markers display the output waveforms in Probe at the end of the simulation. The input voltage is specified by an AC source as shown in [Figure 2.16\(b\)](#). The AC Analysis is set at the Analysis Setup menu as shown in [Figure 2.16\(c\)](#), and its specifications are set from the AC Sweep menu, also shown in [Figure 2.16\(c\)](#).

The circuit file is similar to that of Example 2.2, except that the statements for the type of analysis and output are different. The frequency response analysis is invoked by the .AC command, whose format is

```
.AC DEC NP FSTART FSTOP
```

where

```
DEC =sweep by decade
NP =number of points per decade
FSTART =starting frequency
FSTOP =ending (or stop) frequency
```

For NP = 100, FSTART = 100 Hz, and FSTOP = 100 kHz, the statement is

```
.AC DEC 100 100 100KHZ
```

The magnitude and phase of voltage V(3) are specified as VM(3) and VP(3). The statement to plot is

```
.PLOT AC VM(3) VP(3)
```

The input voltage is AC, and the frequency is variable. We can consider a voltage source with a peak magnitude of 1 V. The statement for an independent voltage source is

```
VIN 7 0 AC 1V
```

The circuit file contains the following statements:

**Example 2.4 Frequency response of RLC circuits**

```
SOURCE   ■ * vin is an independent voltage source whose frequency
            is varied
            * by PSpice during the frequency response analysis.
            VI1 1 0 AC 1V ; Ac voltage of 1 V
            VI2 4 0 AC 1V ; Ac voltage of 1 V
            VI3 7 0 AC 1V ; Ac voltage of 1 V
CIRCUIT  ■■ R1 1 2 2 L1 2 3 50UH
```

```

C1 3 0 10UF
R2 4 5 1
L2 5 6 50UH
C2 6 0 10UF
R3 7 8 8
L3 8 9 50UH
C3 9 0 10UF

```

**ANALYSIS** ■■■ \* The frequency response analysis is invoked by the .AC command, whose format is

```

* .ACDECNPFSTARTFSTOP
* Refer to Chapter 6 for dot commands.
.ACDEC100100HZ100KHZ
* Plots the results of .AC analysis for the magnitude
and phase of V(3):
.PLOTACVM(3)VP(3)
.PROBE
.END

```

---

The results of the frequency response obtained on the display using the .PROBE command are shown in [Figure 2.17](#). The results of the .PLOT statement can be obtained by printing the contents of the output file EX2.4.OUT. The .AC and .TRAN commands could be added to the same circuit file to perform the corresponding analyses.

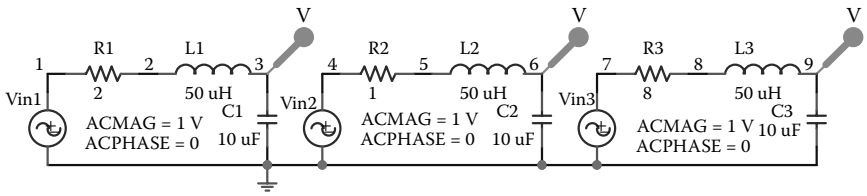
## 2.13 PSPICE SCHEMATICS

If the PSpice student version software is properly installed, it will have the following portions modules:

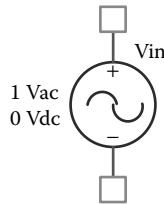
- PSpice Schematics — This is the front-end input interface and is similar to Microsim Schematics version 8.0. Schematics Capture has replaced it and its menu layout has slightly changed, but the basic elements have not.
- PSpice A/D — This is a mixed-signal simulation tool similar to Microsim Design Center, and it is relatively unchanged in OrCAD.
- Probe — This is a graphical postprocessor for viewing the simulation results, similar to Microsim Design Center and relatively unchanged as well.

### 2.13.1 PSPICE SCHEMATICS LAYOUT

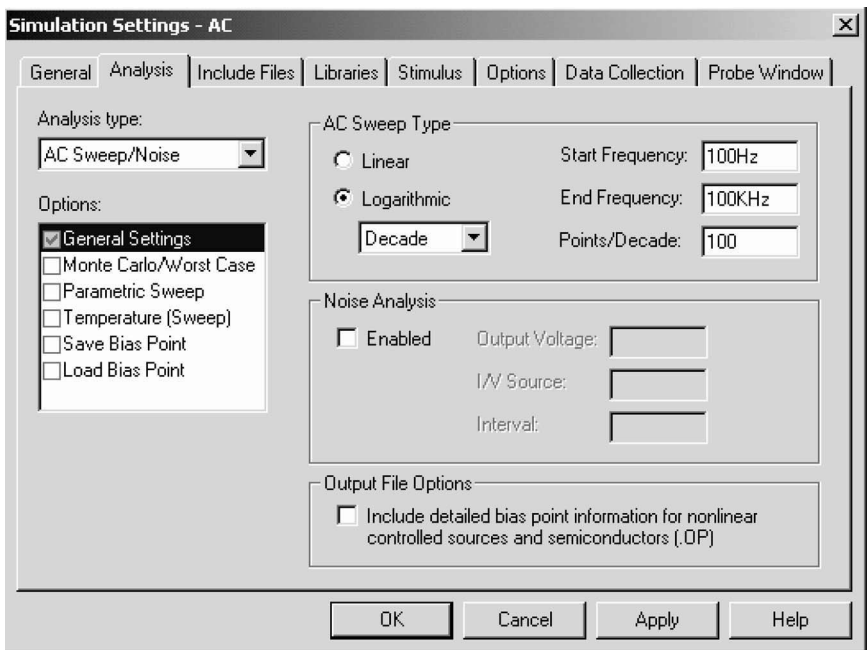
[Figure 2.18](#) shows the layout of PSpice Schematics. The top menu shows all the main menus. The right-hand-side menu shows the Schematic Drawing menu for selecting and placing parts. For example, a part can be placed from the Get New Parts of the Drawing menu as shown in [Figure 2.19](#). [Figure 2.20\(a\)](#) shows the



(a)



(b)



(c)

**FIGURE 2.16** PSpice schematic for Example 2.14. (a) PSpice schematic, (b) specifications of AC source, (c) AC analysis and sweep setup.

Example 2.4 Frequency response of RLC-circuits

Temperature: 27.0

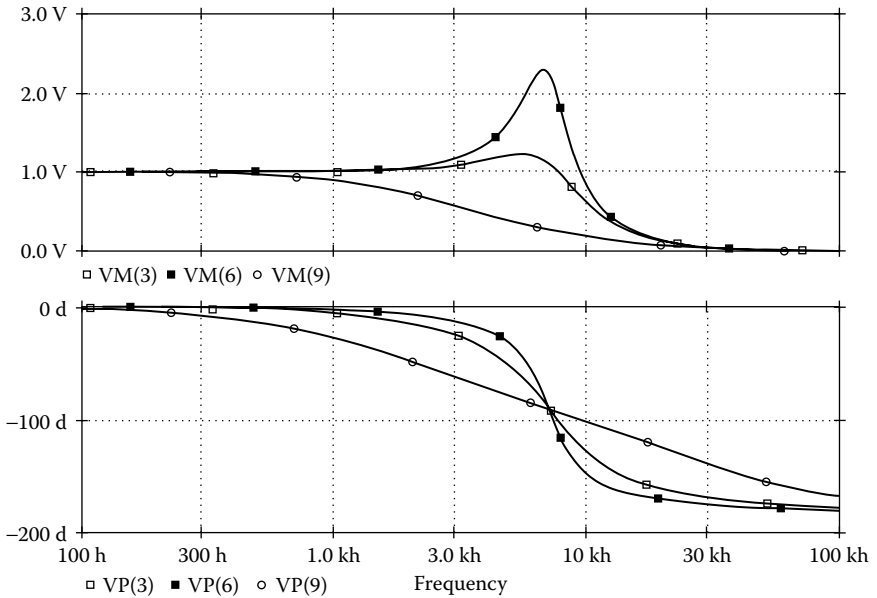


FIGURE 2.17 Frequency responses of RLC circuit for Example 2.4.

Parts menu for selecting a part, and Figure 2.20(b) shows the menu for placing a part (e.g., R) from the Schematics library (e.g., Analog).

Figure 2.21(a) shows the Analysis menu for selecting the setup, and Figure 2.21(b) shows the menu for selecting analysis type (e.g., DC sweep, time domain, AC sweep, and bias point), temperature sweep, and Monte Carlo/worst case.

2.13.2 PSpice A/D

PSpice A/D combines PSpice and Probe for editing and running a simulation file, viewing output and simulation results, and setting the simulation profile. Its menu is identical to that of OrCAD Capture and is shown in Figure 2.22(a). The left-hand-side menu as shown in Figure 2.22(b) allows viewing the simulation results and setting simulation profiles.

2.13.3 PROBE

Probe menu is included in PSpice A/D. Figure 2.23(a) shows the trace menu for plotting the output variables, and Figure 2.23(b) shows the menu for setting the plot axes and the number of plots.

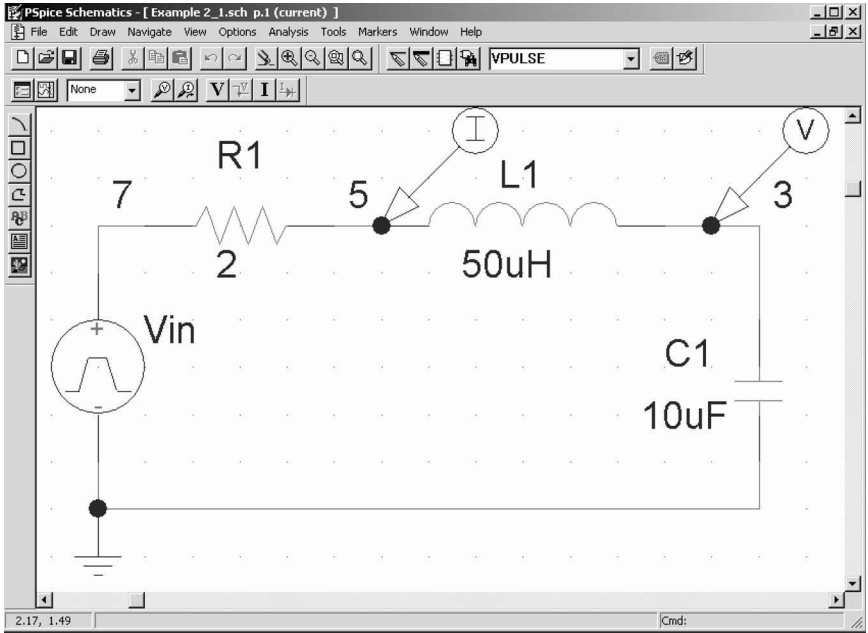
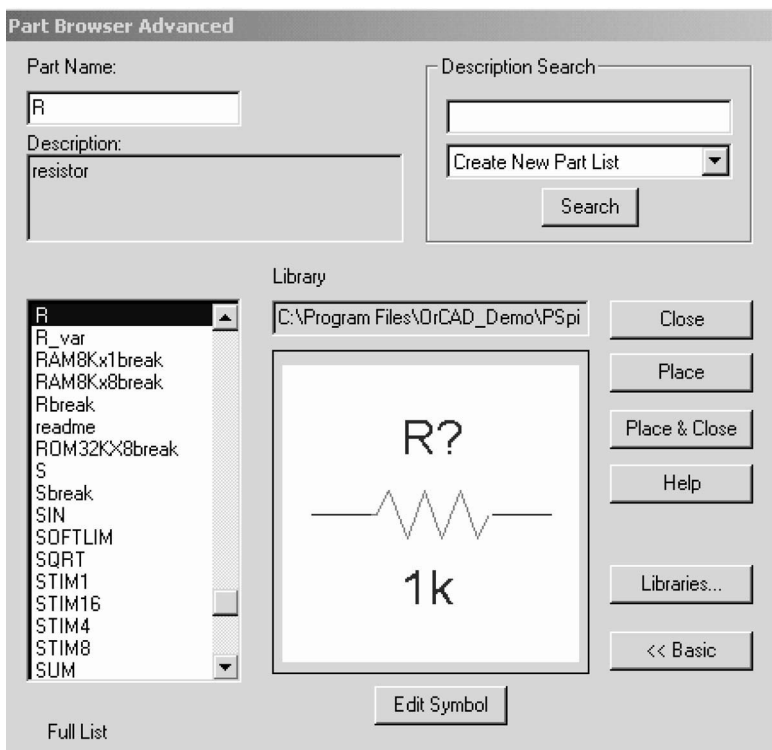


FIGURE 2.18 PSpice schematics.

Draw	Navigate	View	Option
		Repeat	Space
		Place Part	Ctrl+P
		Wire	Ctrl+W
		Bus	Ctrl+B
		Block	
		Arc	
		Circle	
		Box	
		Polyline	
		Text...	Ctrl+T
		Text Box	
		Insert Picture...	
		Get New Part...	Ctrl+G
		Rewire	Ctrl+D

FIGURE 2.19 Draw menu for “Get New Parts.”



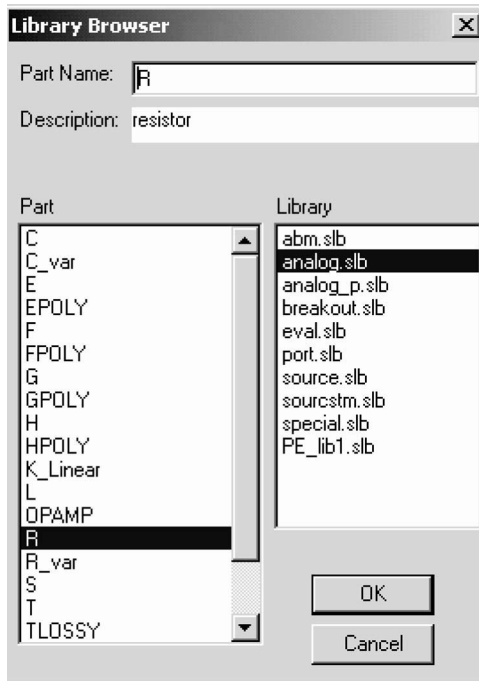
(a)

**FIGURE 2.20** Parts and library menus. (a) Part menu, (b) selecting a part from Schematics library.

## 2.14 IMPORTING MICROSIM SCHEMATICS IN ORCAD CAPTURE

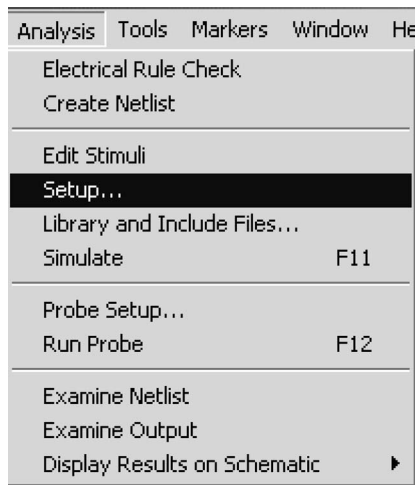
OrCAD Capture uses a file extension `.OPJ`. However, Microsim Schematics version 9.1 or below uses the file extension `.SCH`. Therefore, a Schematics file can be run directly without conversion on OrCAD capture. A Schematics file (`.SCH`) can be imported to OrCAD Capture from its File menu as shown in [Figure 2.24\(a\)](#). It requires identifying the location of the following files:

- The name and the location of the Schematics file with `.SCH` extension
- The name and the location of the Capture file with `.OPJ` extension, where the imported file will be saved as shown in [Figure 2.24\(b\)](#).
- The name and the location of the schematic configuration file with `.INI` extension. Once the conversion is completed, the imported file with `.OPJ` extension can be simulated on OrCAD Capture.



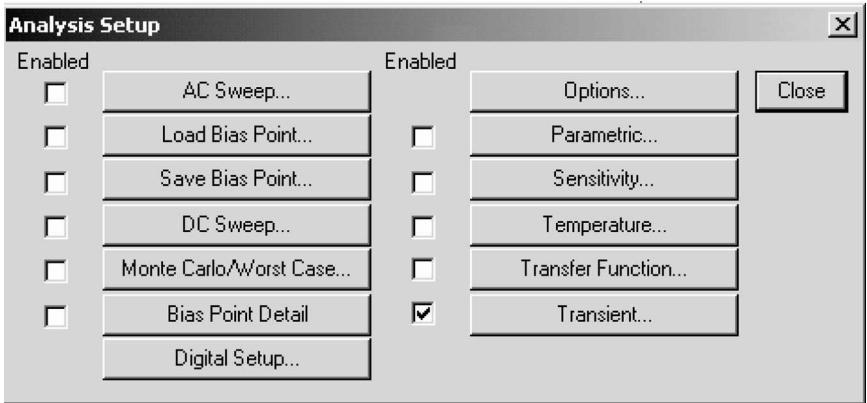
(b)

FIGURE 2.20 (continued).



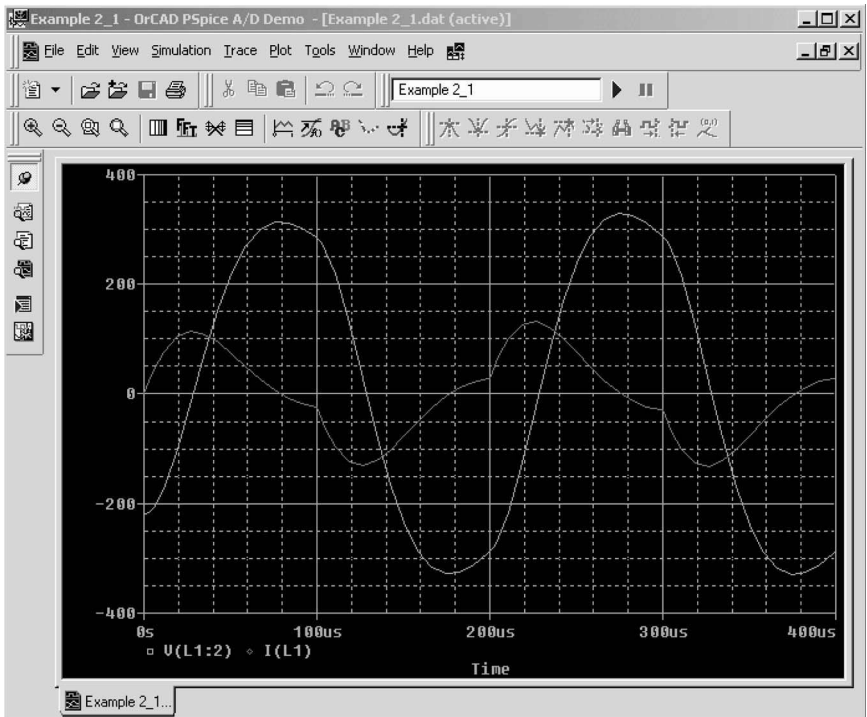
(a)

FIGURE 2.21 Analysis Setup menu. (a) Analysis menu, (b) enabling the analysis type: Transient.



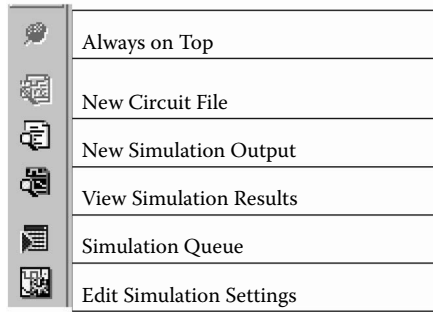
(b)

FIGURE 2.21 (continued).



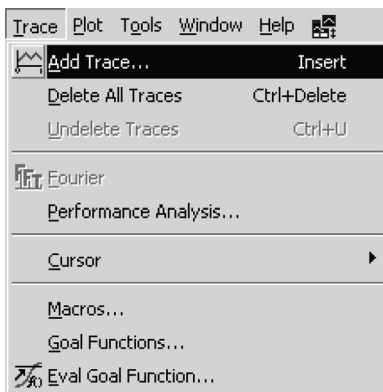
(a)

FIGURE 2.22 PSpice menu. (a) PSpice A/D menu, (b) PSpice A/D Viewing and Setting menus.

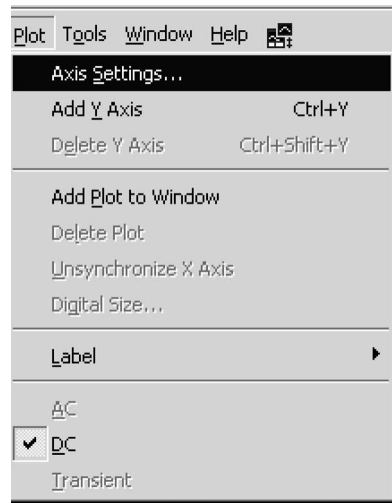


(b)

FIGURE 2.22 (continued).

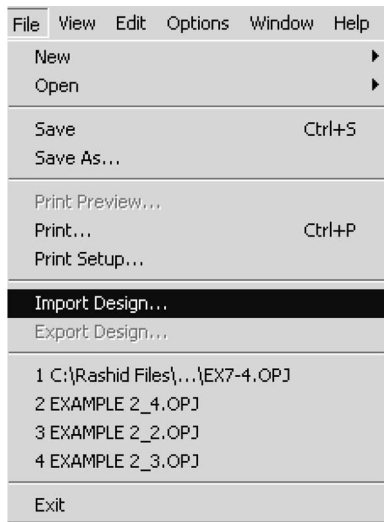


(a)

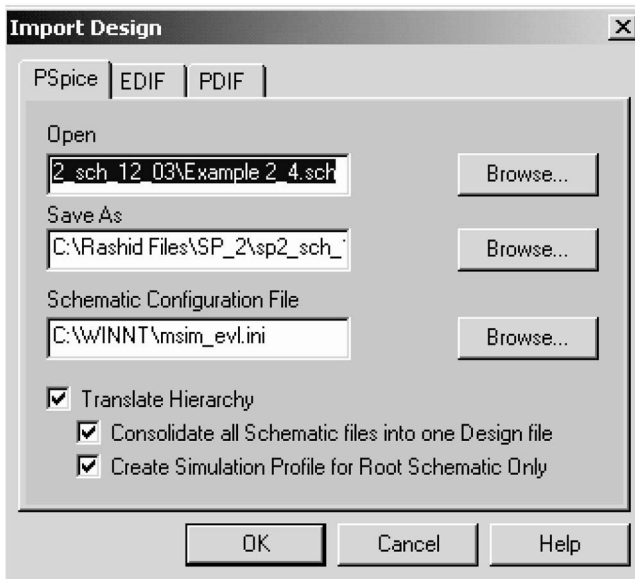


(b)

FIGURE 2.23 Probe menu of PSpice A/D. (a) Trace menu of Probe, (b) Plot menu of Probe.



(a)



(b)

**FIGURE 2.24** Importing Microsim Schematics file. (a) File menu, (b) design import.

## Suggested Reading

1. M. H. Rashid, *Introduction to PSpice Using OrCAD for Circuits and Electronics*, 3rd ed., Englewood Cliffs, NJ: Prentice-Hall, 2003.
2. M.H. Rashid, *SPICE For Power Electronics and Electric Power*, Englewood Cliffs, NJ: Prentice-Hall, 1993.
3. Paul W. Tuinenga, *SPICE: A guide to circuit simulation and analysis using PSPICE*, 3rd ed., Englewood Cliffs, NJ: Prentice-Hall, 1995.
4. *PSpice Manual*, Irvine, CA: MicroSim Corporation, 1992.

## PROBLEMS

### 2.1

The *RLC* circuit of Figure P2.1 is to be simulated to calculate and plot the transient response from 0 to 2 msec with an increment of 10  $\mu\text{sec}$ . The voltage across resistor *R* is the output. The input and output voltages are to be plotted on an output file. The results should also be available for display and as hard copy using the .PROBE command.

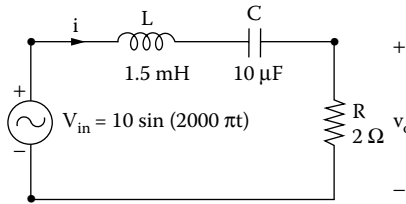


FIGURE P2.1 Series RLC circuit.

### 2.2

Repeat Problem 2.1 for the circuit of Figure P2.2, where the output is taken across capacitor *C*.

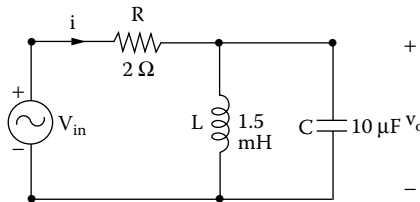
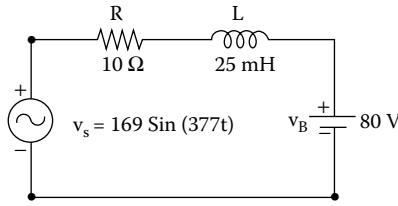


FIGURE P2.2 Series and parallel RLC circuit.

### 2.3

Repeat Problem 2.1 for the circuit of Figure P2.3, where the output is the current  $i_s$  through the circuit.



**FIGURE P2.3** Series RLC circuit.

**2.4**

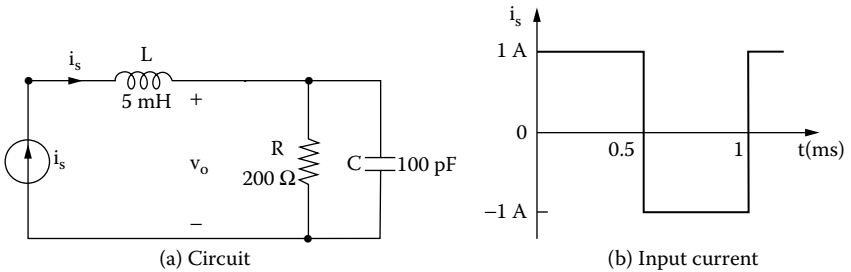
Repeat Problem 2.1 if the input is a step input, as shown in [Figure 2.3\(b\)](#).

**2.5**

Repeat Problem 2.2 if the input is a step input, as shown in [Figure 2.3\(b\)](#).

**2.6**

The *RLC* circuit of [Figure P2.6\(a\)](#) is to be simulated to calculate and plot the transient response from 0 to 2 msec with an increment of 5  $\mu$ sec. The input is a step current, as shown in [Figure P2.6\(b\)](#). The voltage across resistor *R* is the output. The input and output voltages are to be plotted on an output file. The results should also be available for display and as hard copy, using the `.PROBE` command.



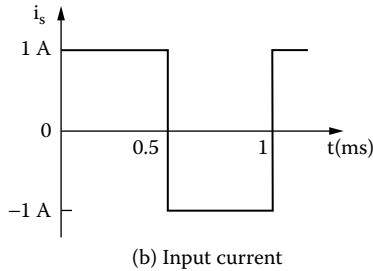
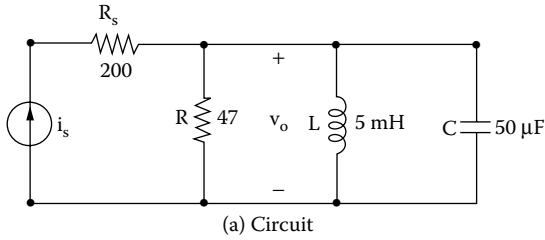
**FIGURE P2.6** Series and parallel RLC circuit.

**2.7**

Repeat Problem 2.6 for the circuit of [Figure P2.7](#), where the output is taken across capacitor *C*.

**2.8**

The circuit of [Figure P2.2](#) is to be simulated to calculate and print the frequency response over the frequency range 10 to 100 kHz with a decade increment and



**FIGURE P2.7** RLC circuit with a current source.

10 points per decade. The peak magnitude and phase angle of the voltage across the resistor are to be printed on the output file. The results should also be available for display and as hard copy, using the `.PROBE` command.

## 2.9

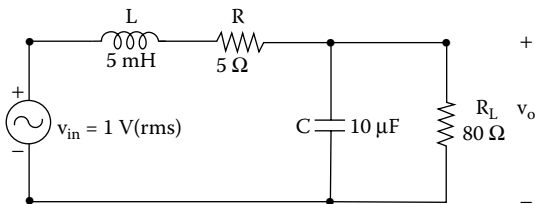
Repeat Problem 2.8 for the circuit of [Figure P2.6](#).

## 2.10

Repeat Problem 2.8 for the circuit of [Figure P2.7](#).

## 2.11

Repeat Problem 2.8 for the circuit of [Figure P2.11](#).



**FIGURE P2.11** RLC circuit with a parallel load.

---

# 3 Defining Output Variables

The learning objectives of this chapter are:

- Defining and specifying the output variables for AC and transient analysis
- Defining and specifying the magnitude and phase angles of output variables for AC analysis
- Defining and specifying the output variables for noise analysis

## 3.1 INTRODUCTION

PSpice has some unique features for printing or plotting output voltages or currents by .PRINT and .PLOT statements. These statements, which may have up to eight output variables, are discussed in [Chapter 6](#). The output variables that are allowed depend on the type of analysis:

DC sweep and transient analysis  
AC analysis  
Noise analysis

## 3.2 DC SWEEP AND TRANSIENT ANALYSIS

DC sweep and transient analysis use the same type of output variables. The variables can be divided into two types, voltage output and current output. A variable can be assigned the symbol or terminal symbol of a device (or element) to identify whether the output is the voltage across the device (or element) or the current through it. [Table 3.1](#) shows the symbols for two-terminal elements. [Table 3.2](#) shows the symbols and terminal symbols for three- and four-terminal devices.

### 3.2.1 VOLTAGE OUTPUT

The output voltages for DC sweep and transient analysis can be obtained by the following statements:

V(<node>)      Voltage at <node> with respect to ground  
V(N1,N2)      Voltage at node  $N_1$  with respect to node  $N_2$   
V(<name>)      Voltage across two-terminal device, <name>

---

**TABLE 3.1**  
**Symbols for Two-Terminal Elements**

First Letter	Element
C	Capacitor
D	Diode
E	Voltage-controlled voltage source
F	Current-controlled current source
G	Voltage-controlled current source
H	Current-controlled voltage source
I	Independent current source
L	Inductor
R	Resistor
V	Independent voltage source

---



---

**TABLE 3.2**  
**Symbols and Terminal Symbols for Three-  
or Four-Terminal Devices**

First Letter	Device	Terminals
B	GaAs MESFET	D (drain) G (gate) S (source)
J	JFET	D (drain) G (gate) S (source)
M	MOSFET	D (drain) G (gate) S (source) B (bulk, substrate)
Q	BJT	C (collector) B (base) E (emitter) S (substrate)
Z	IGBT	G (Gate) C (Collector) E (Emitter)

---

$V_x(\langle \text{name} \rangle)$  Voltage at terminal  $x$  of three-terminal device,  $\langle \text{name} \rangle$

$V_{xy}(\langle \text{name} \rangle)$  Voltage across terminals  $x$  and  $y$  of three-terminal device,  $\langle \text{name} \rangle$

$V_z(\langle \text{name} \rangle)$  Voltage at port  $z$  of transmission line,  $\langle \text{name} \rangle$

The meaning of the PSpice variables is given in the following text:

PSpice Variables	Meaning
V(0)	Voltage at the ground terminal
V(R1:1)	Voltage at terminal 1 of resistor $R_1$
V(R1:2)	Voltage at terminal 2 of resistor $R_1$
V1(R1)	Voltage at terminal 1 of resistor $R_1$
V2(R1)	Voltage at terminal 2 of resistor $R_1$
V(Vin+)	Voltage at positive terminal (+) of voltage source $V_{in}$
V(Vin-)	Voltage at negative terminal (-) of voltage source $V_{in}$
V(5)	Voltage at node 5 with respect to ground
V(4,2)	Voltage of node 4 with respect to node 2
V(R1)	Voltage of resistor $R_1$ , where the first node (as defined in the circuit file) is positive with respect to the second node
V(L1)	Voltage of inductor $L_1$ , where the first node (as defined in the circuit file) is positive with respect to the second node
V(C1)	Voltage of capacitor $C_1$ , where the first node (as defined in the circuit file) is positive with respect to the second node
V(D1)	Voltage across diode $D_1$ , where the anode positive is positive with respect to the cathode
VC(Q3)	Voltage at the collector of transistor $Q_3$ , with respect to ground
VDS(M6)	Drain-source voltage of MOSFET $M_6$
VB(T1)	Voltage at port B of transmission line $T_1$

*Note:* SPICE and some versions of PSpice do not permit measuring voltage across a resistor, an inductor, and a capacitor [e.g., V(R1), V(L1), and V(C1)]. This type of statement is applicable only to outputs by .PLOT and .PRINT commands.

### 3.2.2 CURRENT OUTPUT

The output currents for DC sweep and transient analysis can be obtained by the following statements:

- I(<name>) Current through <name>
- Ix(<name>) Current into terminal  $x$  of <name>
- Iz(<name>) Current at port  $z$  of transmission line, <name>

The meaning of the PSpice variables is given in the following text:

PSpice Variables	Meaning
I(R1)	Current through the resistor $R_1$ , flowing from terminal 1 to terminal 2
I(Vin)	Current flowing from the positive terminal to the negative terminal of the source $V_{in}$

I(VS)	Current flowing into DC source $V_s$
I(R5)	Current flowing into resistor $R_5$ , where the current is assumed to flow from the first node (as defined in the circuit file) through $R_5$ to the second node
I(D1)	Current into diode $D_1$
IC(Q4)	Current into the collector of transistor $Q_4$
IG(J1)	Current into gate of JFET $J_1$
ID(M5)	Current into drain of MOSFET $M_5$
IA(T1)	Current at port A of transmission line $T_1$

---

*Note:* SPICE and some versions of PSpice do not permit measuring the current through a resistor [e.g., I(R5)]. The easiest way is to add a dummy voltage source of 0 V (say, VX = 0 V) and to measure the current through that source [e.g., I(VX)].

### 3.2.3 POWER OUTPUT

The following statement can give the instantaneous power dissipation (VI) of an element for DC and transient analysis:

W(<name>) Power absorbed by the element <name>

The meaning of the PSpice variables is given in the following text:

PSpice Variables	Meaning
W(R1)	Apparent power (VI product) of resistor $R_1$
W(Vin)	Apparent power (VI product) of source $V_{in}$

---

#### EXAMPLE 3.1 DEFINING THE OUTPUT VARIABLES OF A BJT CIRCUIT

A DC circuit with a bipolar transistor is shown in [Figure 3.1](#). Write the various currents and voltages in the forms that are allowed by PSpice. The DC sources of 0 V are introduced to measure currents  $I_1$  and  $I_2$ .

#### SOLUTION

Symbol	PSpice Variable	Meaning
$I_B$	IB(Q1)	Base current of transistor $Q_1$
$I_C$	IC(Q1)	Collector current of transistor $Q_1$
$I_E$	IE(Q1)	Emitter current of transistor $Q_1$
$I_S$	I(VCC)	Current through voltage source $V_{cc}$
$I_1$	I(VX)	Current through voltage source $V_x$
$I_2$	I(VY)	Current through voltage source $V_y$
$V_B$	VB(Q1)	Voltage at the base of transistor $Q_1$

$V_C$	VC(Q1)	Voltage at the collector of transistor $Q_1$
$V_E$	VE(Q1)	Voltage at the emitter of transistor $Q_1$
$V_{CE}$	VCE(Q1)	Collector–emitter voltage of transistor $Q_1$
$V_{BE}$	VBE(Q1)	Base–emitter voltage of transistor $Q_1$

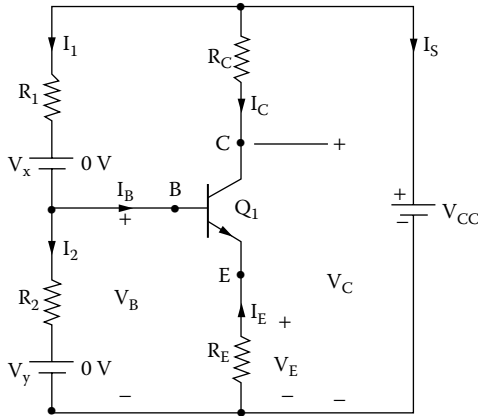


FIGURE 3.1 DC circuit with a bipolar transistor.

**EXAMPLE 3.2 DEFINING THE OUTPUT VARIABLES OF AN RLC CIRCUIT**

An RLC circuit with a step input is shown in Figure 3.2. Write the various currents and voltages in the forms that are allowed by PSpice.

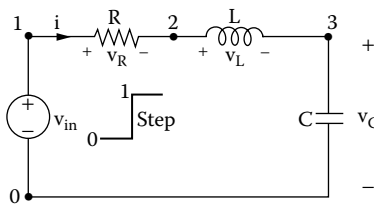


FIGURE 3.2 RLC circuit with a step input.

**SOLUTION**

After the simulation is completed, all possible output variables can be displayed from the Add Traces menu of the PSpice A/D menu as shown in Figure 3.3. Analog operations as shown in Figure 3.3 can also be performed to plot the traces of certain output functions. Note that for transient analysis, time is a variable.

Symbol	PSpice Variable	Meaning
$i_R$	I(R)	Current through resistor $R$
$i_L$	I(L)	Current through inductor $L$
$i_C$	I(C)	Current through capacitor $C$
$i_{in}$	I(VIN)	Current flowing into voltage source $v_{in}$
$v_3$	V(3)	Voltage of node 3 with respect to ground
$v_{2,3}$	V(2,3)	Voltage of node 2 with respect to node 3
$v_{1,2}$	V(1,2)	Voltage of node 1 with respect to node 2
$v_R$	V(R)	Voltage of resistor $R$ where the first node (as defined in the circuit file) is positive with respect to the second node
$v_L$	V(L)	Voltage of inductor $L$ where the first node (as defined in the circuit file) is positive with respect to the second node
$v_C$	V(C)	Voltage of inductor $L$ where the first node (as defined in the circuit file) is positive with respect to the second node

*Note:* SPICE and some versions of PSpice do not permit measuring voltage across a resistor, an inductor, and a capacitor [e.g., V(R1), V(L1), and V(C1)]. This type of statement is applicable only to outputs by .PLOT and .PRINT commands.

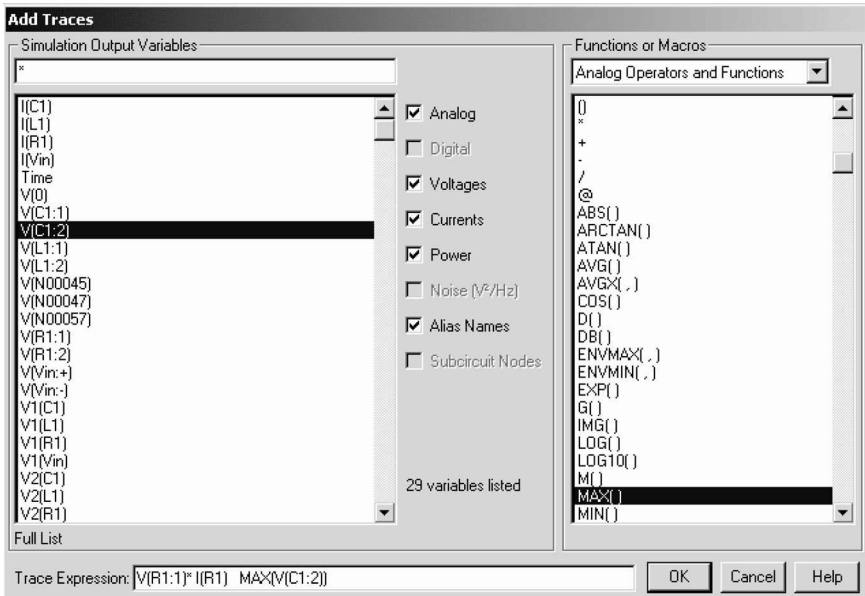


FIGURE 3.3 Simulation output variables.

### 3.3 AC ANALYSIS

In AC analysis, the output variables are sinusoidal quantities and are represented by complex numbers. An output variable can have magnitude, magnitude in decibels, phase, group delay, real part, and imaginary part. A suffix is added to the output variables listed in Subsection 3.2.1 and Subsection 3.2.2 as follows:

Suffix	Meaning
(none)	Peak magnitude
M	Peak magnitude
DB	Peak magnitude in decibels
P	Phase in radians
G	Group delay ( $-\delta_{\text{phase}}/\delta_{\text{frequency}}$ )
R	Real part
I	Imaginary part

#### 3.3.1 VOLTAGE OUTPUT

The statement variables for AC analysis are similar to those for DC sweep and transient analysis, provided that the suffixes are added as illustrated:

PSpice Variable	Meaning
VP(R1:1)	Phase angle of the voltage at terminal 1 of resistor $R_1$
VP(R1:2)	Phase angle of the voltage at terminal 2 of resistor $R_1$
VM(R1:1)	Magnitude of the voltage at terminal 1 of resistor $R_1$
VM(R1:2)	Magnitude of the voltage at terminal 2 of resistor $R_1$
VP(Vin+)	Phase angle of the voltage at positive terminal (+) of voltage source $V_{\text{in}}$
VM(5)	Magnitude of voltage at node 5 with respect to ground
VM(4,2)	Magnitude of voltage at node 4 with respect to node 2
VDB(R1)	Decibel magnitude of voltage across resistor $R_1$ , where the first node (as defined in the circuit file) is assumed to be positive with respect to the second node
VP(D1)	Phase of anode voltage of diode $D_1$ with respect to cathode
VCM(Q3)	Magnitude of the collector voltage of transistor $Q_3$ with respect to ground
VDSP(M6)	Phase of the drain-source voltage of MOSFET $M_6$
VBP(T1)	Phase of voltage at port B of transmission line $T_1$
VR(2,3)	Real part of voltage at node 2 with respect to node 3
VI(2,3)	Imaginary part of voltage at node 2 with respect to node 3

#### 3.3.2 CURRENT OUTPUT

The statement variables for AC analysis are similar to those for DC sweep and transient responses. However, only the currents through the elements listed in

**TABLE 3.3**  
**Current Through Elements**  
**for AC Analysis**

First Letter	Element
C	Capacitor
I	Independent current source
L	Inductor
R	Resistor
T	Transmission line
V	Independent voltage source

Table 3.3 are available. For all other elements, a zero-valued voltage source must be placed in series with the device (or device terminal) of interest. Then a print or plot statement should be used to determine the current through this voltage source.

The meaning of the PSpice statement variables is given in the following text:

PSpice Variable	Meaning
IP(R1)	Phase angle of the current through the resistor $R_1$ flowing from terminal 1 to terminal 2
IM(R1)	Magnitude of the current through the resistor $R_1$ flowing from terminal 1 to terminal 2
IP(Vin+)	Phase angle of the current flowing from the positive terminal to the negative terminal of the source $V_{in}$ .
IM(R5)	Magnitude of current through resistor $R_5$
IR(R5)	Real part of current through resistor $R_5$
II(R5)	Imaginary part of current through resistor $R_5$
IM(VIN)	Magnitude of current through source $v_{in}$
IR(VIN)	Real part of current through source $v_{in}$
II(VIN)	Imaginary part of current through source $v_{in}$
IAG(T1)	Group delay of current at port A of transmission line $T_1$

*Note:* If the symbol  $M$  for magnitude is omitted for the AC analysis, PSpice recognizes the variable as the magnitude of a voltage or a current. That is, VM(R1:1) is identical to V(R1:1).

### EXAMPLE 3.3 DEFINING THE OUTPUT VARIABLES OF AN *RLC* CIRCUIT FOR AC ANALYSIS

The frequency response is obtained for the *RLC* circuit of [Figure 3.4](#). Write the various voltages and currents in the forms that are allowed by PSpice. The dummy voltage source of 0 V is introduced to measure current  $I_L$ .

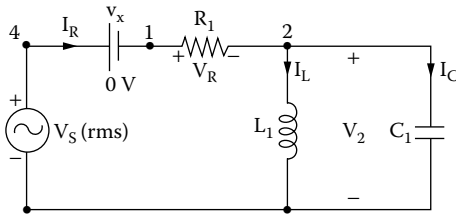


FIGURE 3.4 RLC circuit for Example 3.3.

**SOLUTION**

The meaning of the PSpice statement variables is given in the following text:

Symbol	PSpice Variable	Meaning
$V_2$	VM(2)	Peak magnitude of voltage at node 2
$\angle V_2$	VP(2)	Phase angle of voltage at node 2
$V_{12}$	VM(1,2)	Peak magnitude of voltage between nodes 1 and 2
$\angle V_{12}$	VP(1,2)	Phase angle of voltage between nodes 1 and 2
$I_R$	IM(VX)	Magnitude of current through voltage source $V_x$
$\angle I_R$	IP(VX)	Phase angle of current through voltage source $V_x$
$I_L$	IM(L1)	Magnitude of current through inductor $L_1$
$\angle I_L$	IP(L1)	Phase angle of current through inductor $L_1$
$I_C$	IM(C1)	Magnitude of current through capacitor $C_1$
$\angle I_C$	IP(C1)	Phase angle of current through capacitor $C_1$

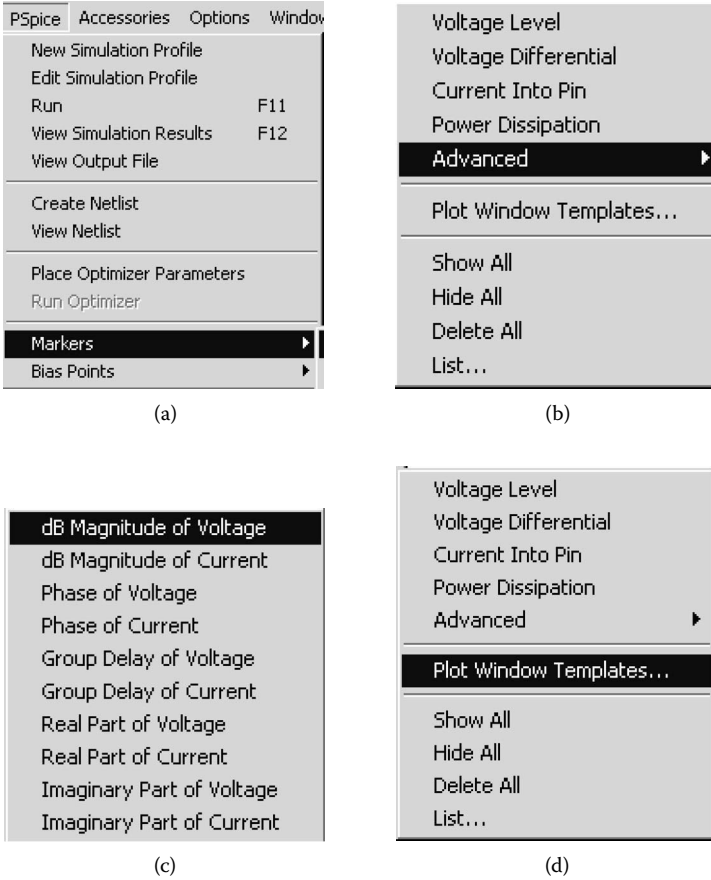
**3.4 OUTPUT MARKERS**

In PSpice Schematics, markers can be selected from the PSpice menu as shown in Figure 3.5(a) to display the voltages, currents, and power dissipation as shown in Figure 3.5(b). The advanced markers can be selected from the Markers menu to display the magnitude, phase, group delay, real part, and imaginary part as shown in Figure 3.5(c). Window Templates, as shown in Figure 3.5(d), can be used to plot certain functions such as average and derivatives as shown in Figure 3.5(e).

**3.5 NOISE ANALYSIS**

For the noise analysis, the output variables are predefined as follows:

Output Variable	Meaning
ONNOISE	Total rms summed noise at output node
INOISE	ONNOISE equivalent at the input node
DB(ONNOISE)	ONNOISE in decibels
DB(INNOISE)	INOISE in decibels



**FIGURE 3.5** PSpice markers. (a) PSpice menu, (b) Markers menu, (c) Advanced menu (d) Markers menu, and (e) Templates menu.

The noise output statement is

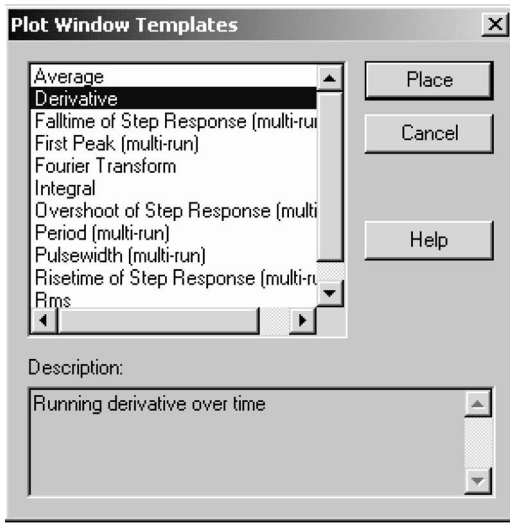
```
.PRINT NOISE INOISE ONOISE
```

*Note:* The noise output from only one device cannot be obtained by a `.PRINT` or `.PLOT` command. However, the print interval on the `.NOISE` statement can be used to output this information. The `.NOISE` command is discussed in Section 6.8.

### 3.6 SUMMARY

The PSpice variables can be summarized as follows:

V(<node>)	Voltage at <node> with respect to ground
V(N1, N2)	Voltage at node $N_1$ with respect to node $N_2$
V(<name>)	Voltage across two-terminal device <name>



(e)

FIGURE 3.5 (continued).

Vx(<name>)	Voltage at terminal <i>x</i> of device <name>
Vxy(<name>)	Voltage at terminal <i>x</i> with respect to terminal <i>y</i> for device <name>
Vz(<name>)	Voltage at port <i>z</i> of transmission line <name>
I(<name>)	Current through device <name>
Ix(<name>)	Current into terminal <i>x</i> of device <name>
Iz(<name>)	Current at port <i>z</i> of transmission line <name>
(none)	Magnitude
M	Magnitude
DB	Magnitude in decibels
P	Phase in radians
G	Group delay ( $-\delta_{\text{phase}}/\delta_{\text{frequency}}$ )
R	Real part
I	Imaginary part

---

# 4 Voltage and Current Sources

The learning objectives of this chapter are:

- Modeling of dependent and independent voltage and current sources
- Specifying dependent and independent voltage and current sources
- Behavioral modeling of voltage- and current-controlled sources with specifications in the form VALUE, TABLE, LAPLACE, FREQ, or as mathematical functions

## 4.1 INTRODUCTION

PSpice allows generating dependent (or independent) voltage and current sources. An independent source can be time variant. A nonlinear source can also be simulated by a polynomial. In this chapter we explain the techniques for generating sources. The PSpice statements for various sources require:

- Source modeling
- Independent sources
- Dependent sources
- Behavioral device modeling

## 4.2 SOURCES MODELING

The independent voltage and current sources that can be modeled by PSpice are:

- Pulse
- Piecewise linear
- Sinusoidal
- Exponential
- Single-frequency frequency modulation

### 4.2.1 PULSE SOURCE

The waveform and parameters of a pulse waveform are shown in [Figure 4.1](#) and [Table 4.1](#). The schematic and the model parameters of a pulse source are shown in [Figure 4.2\(a\)](#). The model parameters that are shown in [Table 4.1](#) can be changed from the menus as shown in [Figure 4.2\(b\)](#). In addition to the transient specifica-

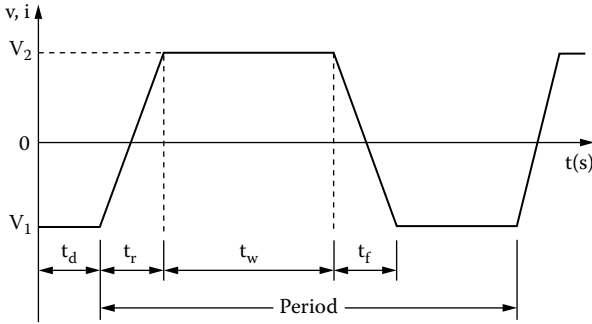
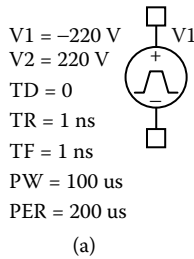


FIGURE 4.1 Pulse waveform.

**TABLE 4.1**  
**Model Parameters of Pulse Sources**

Name	Meaning	Unit	Default
V1	Initial voltage	V	None
V2	Pulsed voltage	V	None
TD	Delay time	sec	0
TR	Rise time	sec	TSTEP
TF	Fall time	sec	TSTEP
PW	Pulse width	sec	TSTOP
PER	Period	sec	TSTOP



New Column...		Apply	Display...	Delete Property	Filter by: Orcad-PSpice									
	Reference	Value	AC	DC	PER	PW	Source Part	TD	TF	TR	V1	V2		
1	S1	V1	VPULSE	1	5	200us	100us	VPULSE.Normal	0	1ns	1ns	-220	220	

(b)

FIGURE 4.2 PSpice schematic for a pulse source. (a) Symbol, (b) editing model parameters.

tions, the DC (i.e., DC=5V) and AC (AC=1V) specifications can be assigned to the same source. The pulse source is used for the transient analysis of a circuit.

The symbol of a pulse source is PULSE and the general form is

```
PULSE (V1 V2 TD TR TF PW PER)
```

V1 and V2 must be specified by the user. TSTEP and TSTOP in Table 4.1 are the incrementing time and stop time, respectively, during transient (.TRAN) analysis.

### 4.2.1.1 Typical Statements

For  $V_1 = -1$ ,  $V_2 = 1$  V,  $t_d = 2$  nsec,  $t_r = 2$  nsec,  $t_f = 2$  nsec, pulse width = 50 nsec, and period = 100 nsec, the model statement is

```
PULSE (-1 1 2NS 2NS 2NS 50NS 100NS)
```

With  $V_1 = 0$ ,  $V_2 = 1$ , the model becomes

```
PULSE (0 1 2NS 2NS 2NS 50NS 100NS)
```

With  $V_1 = 0$ ,  $V_2 = -1$ , the model becomes

```
PULSE (0 -1 2NS 2NS 2NS 50NS 100NS)
```

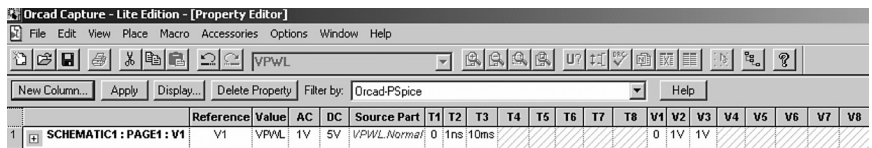
### 4.2.2 PIECEWISE LINEAR SOURCE

A point in a waveform can be described by time  $T_i$  and its value  $V_i$ . Every pair of values  $(T_i, V_i)$  specifies the source value  $V_i$  at time  $T_i$ . The voltage at a time between the intermediate points is determined by PSpice by using linear interpolation.

The schematic of a piecewise linear source is shown in Figure 4.3(a), and the menu for setting the model parameters are shown in Figure 4.3(b). Up to ten



(a)

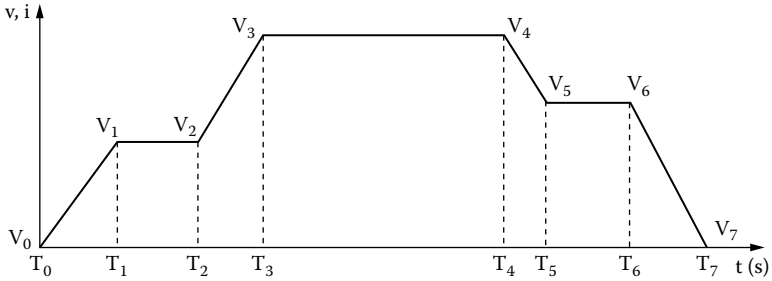


(b)

**FIGURE 4.3** Piecewise linear source in PSpice schematics. (a) Symbol, (b) editing model parameters.

**TABLE 4.2**  
**Model Parameters of PWL Sources**

Name	Meaning	Unit	Default
$T_i$	Time at a point	sec	None
$V_i$	Voltage at a point	V	None



**FIGURE 4.4** Piecewise linear waveform.

points (time, voltages or currents) can be specified. In addition to the transient specifications, the DC (i.e., DC=5V) and AC (AC=1V) specifications can be assigned to the same source.

The symbol of a piecewise linear source is PWL, and the general form is (see Table 4.2):

```
PWL (T1 V1 T2 V2 ... TN VN)
```

#### 4.2.2.1 Typical Statement

The model statement for the typical waveform of Figure 4.4 is

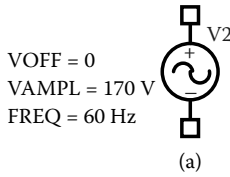
```
PWL (0 3 10US 3V 15US 6V 40US 6V 45US 2V 60US 0V)
```

#### 4.2.3 SINUSOIDAL SOURCE

The schematic and the model parameters of a sinusoidal source are shown in Figure 4.5(a). The model parameters that are shown in Table 4.3 can be changed from the menus as shown in Figure 4.5(b). In addition to the transient specifications, the DC (i.e., DC = 5V) and AC (AC = 1V) specifications can be assigned to the same source.

The symbol of a sinusoidal source is SIN and the general form is (see Table 4.3)

```
SIN (V0 VA FREQ TD ALP THETA)
```



New Column...		Apply	Display...	Delete Property	Filter by:	Orcad-PSpice						
		Reference	Value	AC	DC	DF	FREQ	PHASE	Source Part	TD	VAMPL	VOFF
1	SCHEMATIC1 : PAGE1 : V2	V2	VSIN	1	5	0	60Hz	0	VSIN.Normal	0	170	0

(b)

FIGURE 4.5 Sinusoidal source. (a) Symbol, (b) model parameters.

**TABLE 4.3**  
**Model Parameters of SIN Sources**

Name	Meaning	Unit	Default
VO	Offset voltage	V	None
VA	Peak voltage	V	None
FREQ	Frequency	Hz	1/TSTOP
TD	Delay time	sec	0
ALPHA	Damping factor	1/sec	0
THETA	Phase delay	Degrees	0

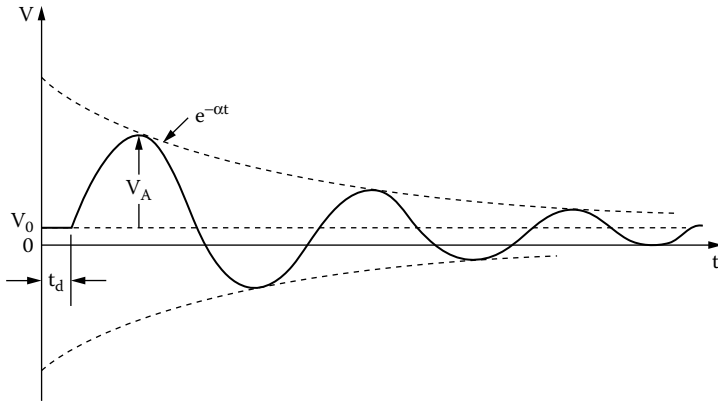
VO and VA must be specified by the user. TSTOP in Table 4.3 is the stop time during transient (.TRAN) analysis. The waveform stays at 0 for a time of TD and then the voltage becomes an exponentially damped sine wave. An exponentially damped sine wave is described by

$$V = V_O + V_A e^{-\alpha(t-t_d)} \sin[2\pi f(t - t_d) - \theta]$$

and this is shown in Figure 4.6.

#### 4.2.3.1 Typical Statements

```
SIN (0 1V 10KHZ 10US 1E5)
SIN (15V 10KHZ 01E5 30DEG)
SIN (0 2V 10KHZ 0 030DEG)
SIN (0 2V 10KHZ)
```



**FIGURE 4.6** Damped sinusoidal waveform.

#### 4.2.4 EXPONENTIAL SOURCE

The waveform and parameters of an exponential waveform are shown in Figure 4.7 and Table 4.4. The schematic of an exponential source is shown in Figure 4.8(a), and the menu for setting the model parameters are shown in Figure 4.8(b). In addition to the transient specifications, the DC (i.e., DC = 5V) and AC (AC = 1V) specifications can be assigned to the same source. TD1 is the rise-delay time, TC1 is the rise-time constant, TD2 is the fall-delay time and TD2 is the fall-time constant. The symbol of exponential sources is EXP and the general form is

EXP (V1 V2 TD1 TC1 TD2 TC2)

V1 and V2 must be specified by the user. TSTEP in Table 4.4 is the incrementing time during transient (.TRAN) analysis. In an EXP waveform, the voltage remains V1 for the first TD1 seconds. Then, the voltage rises exponentially from V1 to V2 with a rise-time constant of TC1. After a time of TD2, the voltage falls exponentially from V2 to V1 with a fall-time constant of TC2. (The values of EXP waveform as well as the values of other time-dependent waveforms at intermediate time points are determined by PSpice by means of linear interpolation.)

**TABLE 4.4**  
**Model Parameters of EXP Sources**

Name	Meaning	Unit	Default
V1	Initial voltage	V	None
V2	Pulsed voltage	V	None
TD1	Rise-delay time	sec	0
TC1	Rise-time constant	sec	TSTEP
TD2	Fall-delay time	sec	TD1 + TSTEP
TC2	Fall-time constant	sec	TSTEP

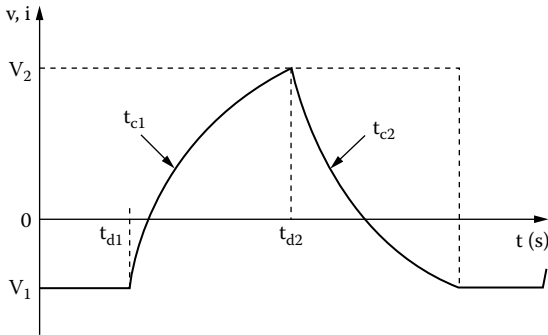
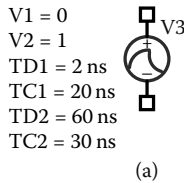


FIGURE 4.7 Exponential waveform.



New Column...		Apply	Display...	Delete Property	Filter by: Orcad-PSpice										
		Reference	Value	AC	DC	Source Part	TC1	TC2	TD1	TD2	V1	V2			
1	SCHEMATIC1 : PAGE1 : V3	V3	VEXP	1	5	VEXP.Normal	20ns	30ns	2ns	60ns	0	1			

(b)

FIGURE 4.8 Exponential Source in PSpice schematic. (a) Symbol, (b) editing model parameters.

### 4.2.4.1 Typical Statements

For  $V1 = 0$ ,  $V2 = 1V$ ,  $TD1 = 2NS$ ,  $TC1 = 20NS$ ,  $TD2 = 60NS$ , and  $TD2 = 30NS$ , the model statement is

```
EXP (0 1 2NS 20NS 60NS 30NS)
```

With  $TRD = 0$ , the statement becomes

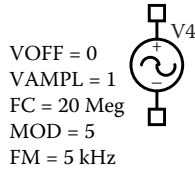
```
EXP (0 1 0 20NS 60NS 30NS)
```

With  $V1 = -1V$  and  $V2 = 2V$ , it is

```
EXP (-1 2 2NS 20NS 60NS 30NS)
```

### 4.2.5 SINGLE-FREQUENCY FREQUENCY MODULATION SOURCE

The schematic of a single-frequency frequency modulation (SFFM) source is shown in Figure 4.9(a), and the menu for setting the model parameters is shown



(a)

New Column...		Apply	Display...	Delete Property	Filter by: Orcad-PSpice						
	Reference	Value	AC	DC	FC	FM	MOD	Source Part	VAMPL	VOFF	
1	SCHEMATIC1: PAGE1: V4	V4	VSFFM	1	5	20Meg	5kHz	5	VSFFM.Normal	1	0

(b)

**FIGURE 4.9** SFFM source in PSpice schematic. (a) Symbol, (b) editing model parameters.

**TABLE 4.5**  
**Model Parameters of SFFM Sources**

Name	Meaning	Unit	Default
VO	Offset voltage	V	None
VA	Amplitude of voltage	V	None
FC	Carrier frequency	Hz	1/TSTOP
MOD	Modulation index		0
FS	Signal frequency	Hz	1/TSTOP

in Figure 4.9(b). In addition to the transient specifications, the DC (i.e., DC = 5V) and AC (AC = 1V) specifications can be assigned to the same source.

The symbol of a source with single-frequency frequency modulation is SFFM, and the general form is (see Table 4.5)

SFFM (VO VA FC MOD FS)

VO and VA must be specified by the user. TSTOP is the stop time during transient (.TRAN) analysis. The waveform is of the form

$$V = V_O + V_A \sin[(2 F_C t) + M \sin(2 F_S t)]$$

#### 4.2.5.1 Typical Statements

For  $V_O = 0$ ,  $V_A = 1V$ ,  $F_C = 30MHz$ ,  $MOD = 5$ , and  $F_S = 5kHz$ , the model statement is

SFFM (0 1V 30MHZ 55KHZ)

With  $V_O = 1mV$  and  $V_A = 2V$ , the model becomes

SFFM (1MV 2V 30MHZ 55KHZ)

### 4.3 INDEPENDENT SOURCES

The independent sources can be time invariant and time variant. They can be currents or voltages, as shown in Figure 4.10. The following notations are used only to explain the general format of a statement and do not appear in the PSpice statement:

(text)	Text within parentheses is a comment
[item]	Optional item
[item]*	Zero or more of optional item
<item>	Item required
<item>*	Zero or more of item required

#### 4.3.1 INDEPENDENT VOLTAGE SOURCE

The symbol of an independent voltage source is V, and the general form is

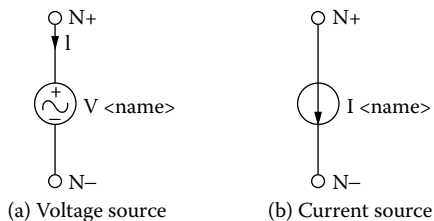
```
V<name>  N+      N-
+        [dc <value>]
+        [ac <(magnitude) value> <(phase) value>]
+        [(transient specifications)]
```

*Note:* The first column with a + (plus) signifies continuation of the PSpice statement. After the + sign, the statement can continue in any column.

The (transient specifications) must be one of the following sources:

PULSE (<parameters>)	For a pulse waveform
PWL (<parameters>)	For a piecewise linear waveform
SIN (<parameters>)	For a sinusoidal waveform
EXP (<parameters>)	For an exponential waveform
SFFM (<parameters>)	For a frequency-modulated waveform

N+ is the positive node and N- is the negative node, as shown in Figure 4.10(a). Positive current flows from node N+ through the voltage source to the negative



**FIGURE 4.10** (a) Voltage source, (b) current source.

node N–. The voltage source need not be grounded. For the DC, AC, and transient values, the default value is zero. None or all of DC, AC, and transient values may be specified. The <(phase) value> is in degrees.

The source is set to the DC value in DC analysis. It is set to AC value in AC analysis. If the <(phase) value> in AC analysis is omitted, the default is 0. The time-dependent source (e.g., PULSE, EXP, SIN, etc.) is assigned for transient analysis. A voltage source may be used as an ammeter in PSpice by inserting a zero-valued voltage source into the circuit for the purpose of measuring current. Because a zero-valued source behaves as a short circuit, there will be no effect on circuit operation.

#### 4.3.1.1 Typical Statements

```
V1      15 0 6V          ; By default, DC specification of 6 V
V2      15 0 DC        6V      ; DC specification of 6 V
VAC     5 6 AC        1V      ; AC specification of 1 V with 0° delay
VACP   5 6 AC        1V 45DEG ; AC specification of 1 V with 45° delay
VPULSE 10 0 PULSE (0 1 2NS 2NS 2NS 50NS 100NS) ; Transient pulse
VIN     25 22 DC 2 AC 1 30 SIN (0 2V 10KHZ)
```

*Note:* VIN assumes 2 V for DC analysis, 1 V with a delay angle of 30° for AC analysis, and a sine wave of 2 V at 10 kHz for transient analysis. This allows source specifications for different analyses in the same statement.

#### 4.3.2 INDEPENDENT CURRENT SOURCE

The symbol of an independent current source is I, and the general form is

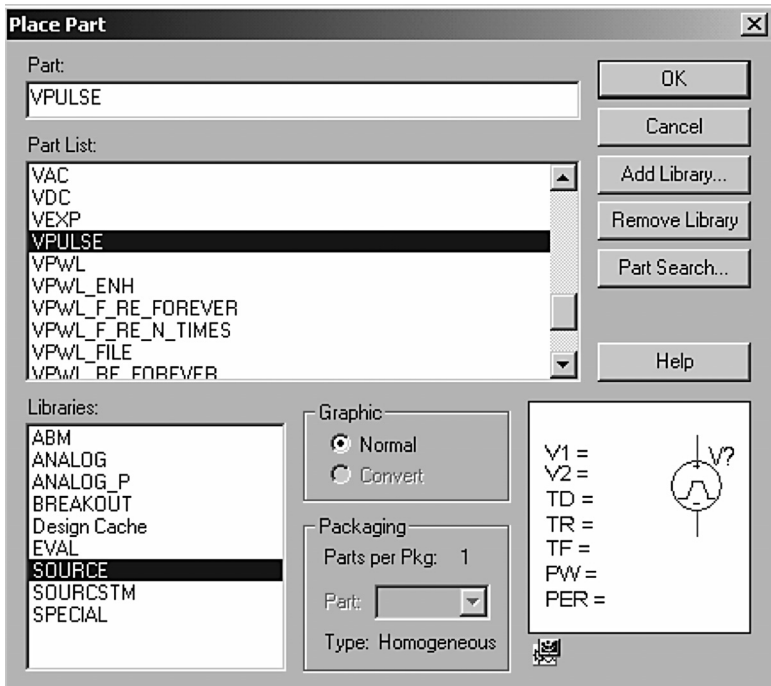
```
I<name> N+      N-
+          [dc <value>]
+          [ac <(magnitude) value> <(phase) value>]
+          [(transient specifications)]
```

The (transient specifications) must be one of the following sources:

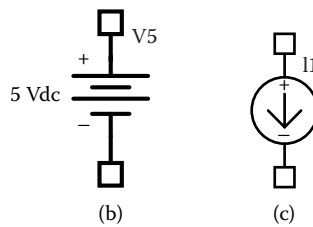
PULSE (<parameters>)	For a pulse waveform
PWL (<parameters>)	For a piecewise linear waveform
SIN (<parameters>)	For a sinusoidal waveform
EXP (<parameters>)	For an exponential waveform
SFFM (<parameters>)	For a frequency-modulated waveform

N+ is the positive node and N– is the negative node, as shown in [Figure 4.10\(b\)](#). Positive current flows from node N+ through the current source to the negative node N–. The current source need not be grounded. The source specifications are similar to those of an independent voltage source.





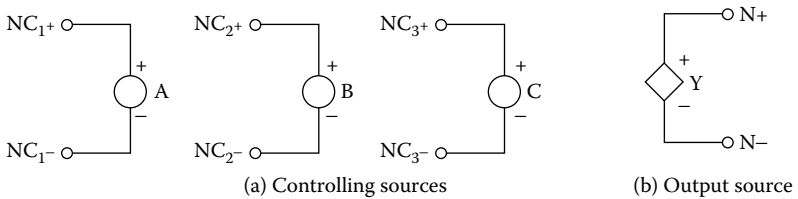
(a)



(b)

(c)

**FIGURE 4.11** Independent DC sources. (a) Sources menu, (b) DC voltage source, (c) DC current source.



(a) Controlling sources

(b) Output source

**FIGURE 4.12** Polynomial source.

number of dimensions. For current-controlled sources, the number of controlling sources must be equal to the number of dimensions. The number of dimensions and the number of coefficients are arbitrary.

For a polynomial of  $n = 1$  with  $A$  as the only controlling variable, the source function takes the form

$$Y = P_0 + P_1A + P_2A^2 + P_3A^3 + P_4A^4 + \dots + P_nA^n$$

where  $P_0, P_1, \dots, P_n$  are the coefficient values, and this is written in PSpice as

$$\text{POLY NC1+ NC1- } P_0 \ P_1 \ P_2 \ P_3 \ P_4 \ P_5 \ \dots \ P_n$$

where NC1+ and NC1- are the positive and negative nodes, respectively, of controlling source  $A$ .

For a polynomial of  $n = 2$  with  $A$  and  $B$  as the controlling sources, the source function  $Y$  takes the form

$$Y = P_0 + P_1A + P_2B + P_3A^2 + P_4AB + P_5B^2 + P_6A^3 \\ + P_7A^2B + P_8AB^2 + P_9B^3 + \dots$$

and this is described in PSpice as

$$\text{POLY(2) NC1+ NC1- NC2+ NC2- } P_0 \ P_1 \ P_2 \ P_3 \ P_4 \ P_5 \ \dots \ P_n$$

where NC1+, NC2+ and NC1-, NC2- are the positive and negative nodes, respectively, of the controlling sources.

For a polynomial of  $n = 3$  with  $A, B,$  and  $C$  as the controlling sources, the source function  $Y$  takes the form

$$Y = P_0 + P_1A + P_2B + P_3C + P_4A^2 + P_5AB + P_6AC + P_7B^2 + P_8BC + P_9C^2 \\ + P_{10}A^3 + P_{11}A^2B + P_{12}A^2C + P_{13}AB^2 + P_{14}ABC + P_{15}AC^2 + P_{16}B^3 \\ + P_{17}B^2C + P_{18}BC^2 + P_{19}C^3 + P_{20}A^4 + \dots$$

and this is written in PSpice as

$$\text{POLY(3) NC1+ NC1- NC2+ NC2- NC3+ NC3- } P_0 \ P_1 \ P_2 \ P_3 \ P_4 \\ P_5 \ \dots \ P_n$$

where NC1+, NC2+, NC3+ and NC1-, NC2-, NC3- are the positive and negative nodes, respectively, of the controlling sources.

#### 4.4.1.1 Typical Model Statements

For  $Y = 2V(10)$ , the model is

```
POLY 10 0 2.0
```

For  $Y = V(5) + 2[V(5)]^2 + 3[V(5)]^3 + 4[V(5)]^4$ , the model is

```
POLY 5 0 0.0 1.0 2.0 3.0 4.0
```

For  $Y = 0.5 + V(3) + 2V(5) + 3[V(3)]^2 + 4V(3)V(5)$ , the model is

```
POLY(2) 3 0 5 0 0.5 1.0 2.0 3.0 4.0
```

For  $Y = V(3) + 2V(5) + 3V(10) + 4[V(3)]^2$ , the model is

```
POLY(3) 3 0 5 0 10 0 0.0 1.0 2.0 3.0 4.0
```

If  $I(VN)$  is the controlling current through voltage source  $VN$ , and  $Y = I(VN) + 2[I(VN)]^2 + 3[I(VN)]^3 + 4[I(VN)]^4$ , the model is

```
POLY VN 0.0 1.0 2.0 3.0 4.0
```

If  $I(VN)$  and  $I(VX)$  are the controlling currents, and  $Y = I(VN) + 2I(VX) + 3[I(VN)]^2 + 4I(VN)I(VX)$ , the model is

```
POLY(2) VN VX 0.0 1.0 2.0 3.0 4.0
```

*Note:* If the source is of one dimension and only one coefficient is specified, as in the first example, in which  $Y = 2V(10)$ , PSpice assumes that  $P_0 = 0$  and the value specified is  $P_1$ . That is,  $Y = 2A$ .

#### 4.4.2 VOLTAGE-CONTROLLED VOLTAGE SOURCE

The dependent sources are shown in [Figure 4.13](#). The symbol of the voltage-controlled voltage source shown in [Figure 4.13\(a\)](#) is E, and it takes the linear form

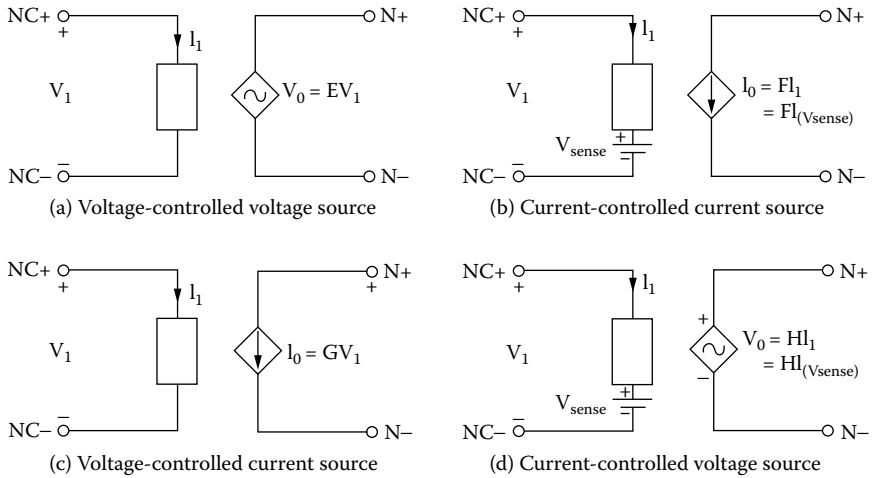
```
E<name> N+ N- NC+ NC- <(voltage gain) value>
```

$N+$  and  $N-$  are the positive and negative output nodes, respectively, and  $NC+$  and  $NC-$  are the positive and negative nodes, respectively, of the controlling voltage. The nonlinear form is

```
E<name> N+ N- [POLY (polynomial specifications)]
+ [VALUE (expression)] [TABLE (expression)]
+ [LAPLACE (expression)] [FREQ (expression)]
```

The POLY description is described in Section 4.4.1. The number of controlling nodes in POLY is twice the number of dimensions. A particular node may appear more than once, and the output and controlling nodes could be the same.

The VALUE, TABLE, LAPLACE, and FREQ descriptions of sources are available only with the analog behavioral modeling option of PSpice and are discussed in Section 4.5.



**FIGURE 4.13** Dependent sources. (a) Voltage-controlled voltage source, (b) current-controlled current source, (c) voltage-controlled current source, (d) current-controlled voltage source.

**4.4.2.1 Typical Statements**

```
EAB 1 2 4 6 1.0 ; Voltage gain of 1
EVOLT 4 7 20 22 2E5 ; Voltage gain of 2E5
```

ENONLIN, which is connected between nodes 25 and 40, is controlled by V(3) and V(5). Its value is given by the polynomial  $Y = V(3) + 1.5V(5) + 1.2[V(3)]^2 + 1.7V(3)V(5)$ , and the model becomes

```
ENONLIN 25 40POLY(2) 3 0 5 0 0.0 1.0 1.5 1.2 1.7
; POLY source
```

E2, which is connected between nodes 10 and 12, is controlled by V(5), and its value is given by the polynomial  $Y = V(5) + 1.5[V(5)]^2 + 1.2[V(5)]^3 + 1.7[V(5)]^4$ , and the model becomes

```
E2 10 12 POLY 5 0 0.0 1.0 1.5 1.2 1.7 ; POLY source
```

**4.4.3 CURRENT-CONTROLLED CURRENT SOURCE**

The symbol of the current-controlled current source shown in Figure 4.13(b) is F, and it takes the linear form

```
F<name> N+ N- VN <(current gain) value>
```

N+ and N- are the positive and negative nodes, respectively, of the current source. VN is a voltage source through which the controlling current flows. The controlling current is assumed to flow from the positive node of VN, through the

voltage source VN, to the negative node of VN. The current through the controlling voltage source, I(VN), determines the output current.

The voltage source VN that monitors the controlling current must be an independent voltage source, and it can have a finite value or zero. If the current through a resistor controls the source, a dummy voltage source of 0 V should be connected in series with the resistor to monitor the controlling current.

The nonlinear form is

```
F<name> N+ N- [POLY (polynomial specifications)]
```

The POLY source is described in Subsection 4.4.1. The number of controlling current sources for the POLY must be equal to the number of dimensions.

#### 4.4.3.1 Typical Statements

```
FAB 1 2 VIN 10 ; Current gain of 10
```

```
FAMP 13 4 VCC 50 ; Current gain of 50
```

FNONLIN, which is connected between nodes 25 and 40, is controlled by the current through voltage source VN. Its value is given by the polynomial  $I = I(VN) + 1.5[I(VN)]^2 + 1.2[I(VN)]^3 + 1.7[I(VN)]^4$ , and the PSpice model becomes

```
FNONLIN 25 40 POLY VN 0.0 1.0 1.5 1.2 1.7
```

#### 4.4.4 VOLTAGE-CONTROLLED CURRENT SOURCE

The symbol of the voltage-controlled current source shown in [Figure 4.13\(c\)](#) is G, and it takes the linear form

```
G<name> N+ N- NC+ NC- <(transconductance) value>
```

N+ and N- are the positive and negative output nodes, respectively, and NC+ and NC- are the positive and negative nodes, respectively, of the controlling voltage.

The nonlinear form is

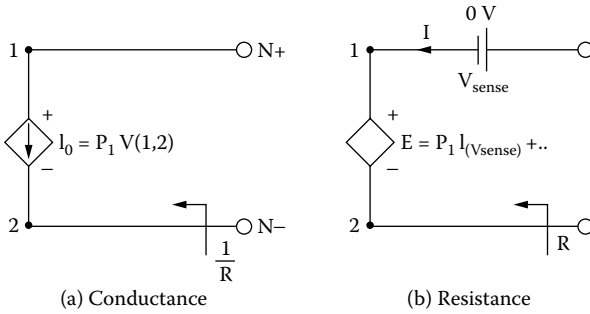
```
G<name> N+ N- [POLY (polynomial specifications)]
+ [VALUE (expression)] [TABLE (expression)]
+ [LAPLACE (expression)] [FREQ (expression)]
```

The POLY description is described in Subsection 4.4.1. The VALUE, TABLE, LAPLACE, and FREQ descriptions of sources are available only with the analog behavioral modeling option of PSpice. These are discussed in Section 4.5.

#### 4.4.4.1 Typical Statements

```
GAB 1 2 4 6 1.0 ; Transconductance of 1
```

```
GVOLT 4 7 20 22 2E5 ; Transconductance of 2E5
```



**FIGURE 4.14** (a) Conductance, (b) resistance.

GNONLIN, which is connected between nodes 25 and 40, is controlled by V(3) and V(5). Its value is given by the polynomial  $Y = V(3) + 1.5V(5) + 1.2[V(3)]^2 + 1.7V(3)V(5)$ , and the model becomes

```
GNONLIN 25 40 POLY(2) 3 0 5 0 0.0 1.0 1.5 1.2 1.7;
POLY source
```

G2, which is connected between nodes 10 and 12, is controlled by V(5), and its value is given by the polynomial  $Y = V(5) + 1.5[V(5)]^2 + 1.2[V(5)]^3 + 1.7[V(5)]^4$ , and the model becomes

```
G2 10 12 POLY 5 0 0.0 1.0 1.5 1.2 1.7 ; POLY source
```

A voltage-controlled current source can be used to simulate conductance if the controlling nodes are the same as the output nodes. This is shown in Figure 4.14(a). For example, the PSpice statement

```
GRES 4 6 4 6 0.1 ; transconductance of 0.1
```

is a linear conductance of 0.1 seimens ( $\Omega^{-1}$  or mhos) with a resistance of  $1/0.1 = 10 \Omega$ . The PSpice statement

```
GMHO 1 2 POLY 1 2 0.0 1.5M 1.7M ; POLY source
```

represents a nonlinear conductance ( $\Omega^{-1}$ ) of the polynomial form

$$I = 1.5 \times 10^{-3}V(1,2) + 1.7 \times 10^{-3}[V(1,2)]^2$$

### 4.4.5 CURRENT-CONTROLLED VOLTAGE SOURCE

The symbol of the current-controlled voltage source shown in Figure 4.13(d) is H, and it takes the linear form

```
H<name> N+ N- VN <(transresistance) value>
```

N+ and N- are the positive and negative nodes, respectively, of the voltage source. VN is a voltage source through which the controlling current flows, and its specifications are similar to those for a current-controlled current source.

The nonlinear form is

```
H<name> N+ N- [POLY (polynomial specifications)]
```

The POLY source is described in Subsection 4.4.1. The number of controlling current sources for the POLY must be equal to the number of dimensions.

#### 4.4.5.1 Typical Statements

```
HAB 1 2 VIN 10
```

```
HAMP 13 4 VCC 50
```

HNONLIN, which is connected between nodes 25 and 40, is controlled by I(VN). Its value is given by the polynomial  $V = I(VN) + 1.5[I(VN)]^2 + 1.2[I(VN)]^3 + 1.7[I(VN)]^4$ , and the model becomes

```
HNONLIN 25 40 POLY VN 0.0 1.0 1.5 1.2 1.7 ; POLY
source
```

A voltage-controlled current source can be applied to simulate resistance if the controlling current is the same as the current through the voltage between the output nodes. This is shown in [Figure 4.8](#). For example, the PSpice statement

```
HRES 4 6 VN 0.1 ; Transresistance of 0.1
```

is a linear resistance of 10  $\Omega$ .

The PSpice statement

```
HOHM 1 2 POLY VN 0.0 1.5M 1.7M ; POLY source
```

represents a nonlinear resistance in ohms of the polynomial form

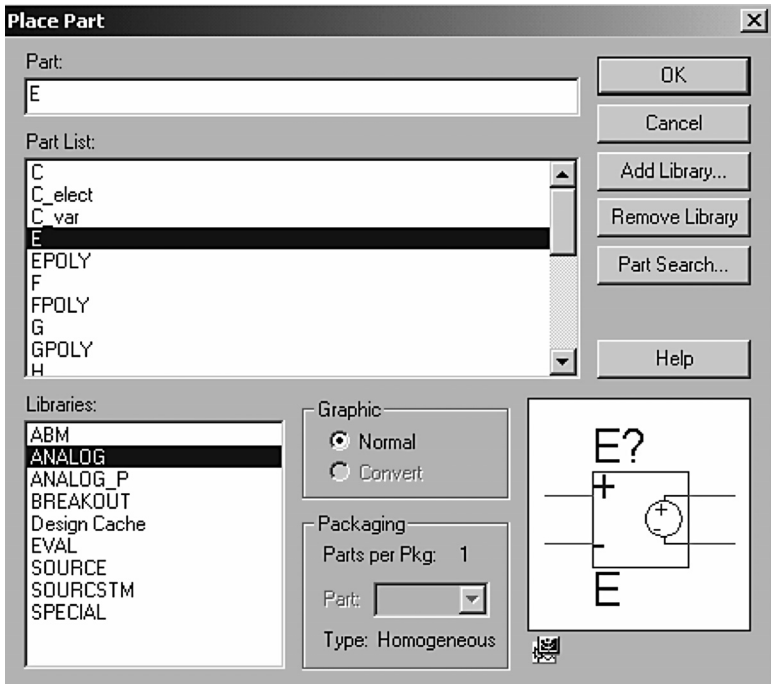
$$H = 1.5 \times 10^{-3}I(VN) + 1.7 \times 10^{-3}[I(VN)]^2$$

#### 4.4.6 SCHEMATIC DEPENDENT SOURCES

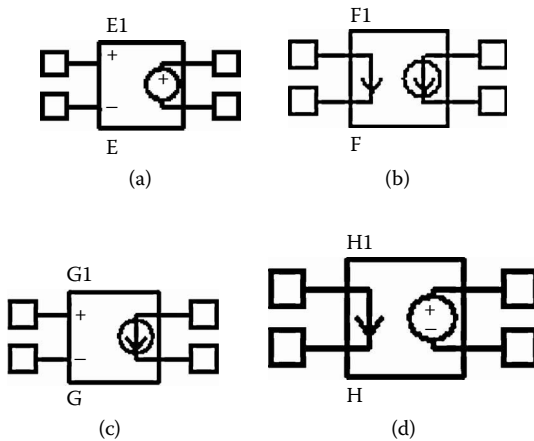
The PSpice analog library analog.slb is shown in [Figure 4.15](#). The voltage-controlled voltage source (E), the current-controlled current source (F), the voltage-controlled current source (G), and the current-controlled voltage source (H) of the PSpice library are shown in [Figure 4.16\(a\)](#) to [Figure 4.16\(d\)](#).

### 4.5 BEHAVIORAL DEVICE MODELING

PSpice allows characterization of devices in terms of the relation between their inputs and outputs. This relation is instantaneous. At each moment in time, there is an output for each value of the input. This representation, known as *behavioral modeling*, is available only with the analog behavioral modeling option of PSpice.



**FIGURE 4.15** Analog library. (a) Voltage-controlled voltage source, (b) current-controlled current source, (c) voltage-controlled current source, (d) current-controlled voltage source.



**FIGURE 4.16** PSpice dependent sources. (a) Voltage-controlled voltage source, (b) current-controlled current source, (c) voltage-controlled current source, (d) current-controlled voltage source.

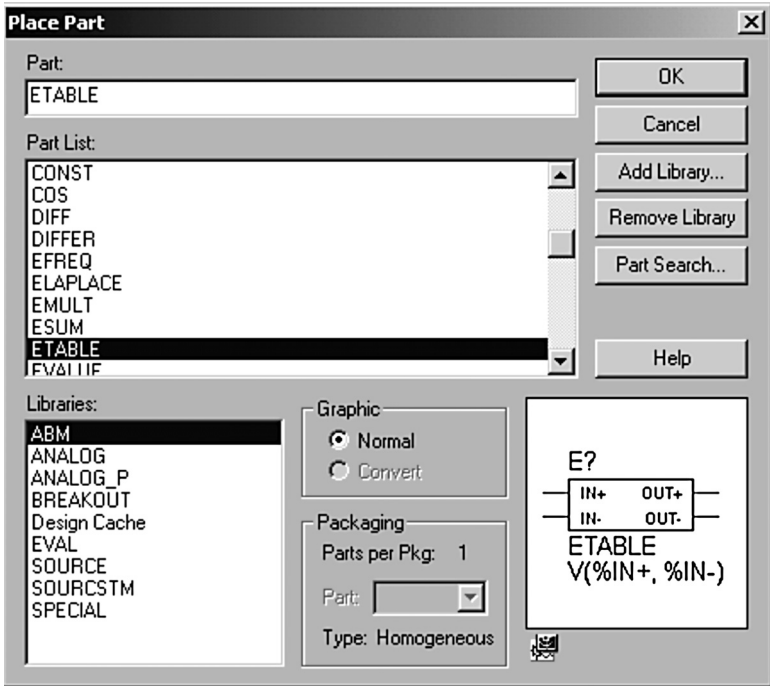


FIGURE 4.17 Analog behavioral models.

This option is implemented as a set of extensions to two of the controlled sources, E and G. Behavioral modeling allows specifications in the form

VALUE  
TABLE  
LAPLACE  
FREQ

The PSpice schematics support many behavioral models such as DIFF, DIFFER, INTG, MULTI, SUM, SQRT, etc. These models can be selected from ab.slb library of the library menu as shown in Figure 4.17.

#### 4.5.1 VALUE

The VALUE extension to the controlled sources of the PSpice library allows an instantaneous transfer function to be written as a mathematical expression in standard notation. The general forms are

$$E<name> \text{ N+ N- VALUE} = \{<expression>\}$$

$$G<name> \text{ N+ N- VALUE} = \{<expression>\}$$

The <expression> itself is enclosed in braces ( { } ). It can contain the arithmetical operators (“+”, “-”, “\*”, and “/”) along with parentheses and the following functions:

Function	Meaning
ABS(x)	x  (absolute value)
SQRT(x)	$\sqrt{x}$

Function	Meaning
EXP(x)	$e^x$
LOG(x)	ln(x) (log of base e)
LOG10(x)	Log(x) (log of base 10)
PWR(x,y)	$ x ^y$
PWRS(x,y)	$+ x ^y$ (if $x > 0$ ), $- x ^y$ (if $x < 0$ )
SIN(x)	sin(x) (x in radians)
COS(x)	cos(x) (x in radians)
TAN(x)	tan(x) (x in radians)
ARCTAN(x)	$\tan^{-1}(x)$ (result in radians)

#### 4.5.1.1 Typical Statements

ESQROOT 2 3 VALUE = {4V\*SQRT (V(5))} ; Square roots

EPWR 1 2 VALUE = {V(4.3)\*I (VSENSE)} ; Product of  $v$  and  $i$

ELOG 3 0 VALUE = {10V\*LOG (I (VS)/10mA)} ; Log of current ratio

GVCO 4 5 VALUE = {15MA\*SIN (6.28\*10kHz\*TIME\*(10V\*V(7)))}

GRATIO 3 6 VALUE = {V (8, 2)/V(9)} ; Voltage ratio

VALUE can be used to simulate linear and nonlinear resistances (or conductances) if appropriate functions are used. A resistance is a current-controlled voltage source. For example, the statement

ERES 2 3 VALUE = {I (VSENSE)\*5K}

is a linear resistance with a value of 5 k $\Omega$ . VSENSE, which is connected in series with ERES, is needed to measure the current through ERES.

A conductance is a voltage-controlled current source. For example, the statement

GCOND 2 3 VALUE = {V(2,3)\*1M}

is a linear conductance with a value of 1 m $\Omega^{-1}$ . The controlling nodes are the same as the output nodes.

Note the following:

1. VALUE should be followed by a space.
2. <expression> must fit on one line.

## 4.5.2 TABLE

The TABLE extension to the controlled sources of the PSpice library allows an instantaneous transfer function to be described by a table. This form is well suited for use with, for example, measured data. The general forms are:

```
E<name> N+ N- TABLE {<expression>} =
+          <<(input)value>, <(output)value>>*
```

```
G<name> N+ N- TABLE {<expression>} =
+          <<(input)value>, <(output)value>>*
```

The <expression> is evaluated, and that value is used to look up an entry in the table. The table itself consists of pairs of values. The first value in each pair is an input, and the second value is the corresponding output. Linear interpolation is done between entries. For values of <expression> outside the table's range, the device's output is a constant with value equal to the entry with the smallest (or largest) input.

### 4.5.2.1 Typical Statements

TABLE can be used to represent the voltage current characteristics of a diode as

```
EDIODE 5 6 TABLE{I (VSENSE)} =
+ (0.0,0.5) (10E-3,0.870) (20E-3,0.98)
(30E-3,1.058)
+ (40E-3,1.115) (50E-3,1.173) (60E-3,1.212)
(70E-3,1.250)
```

TABLE can be used to represent a constant power load  $P = 400$  W with a voltage-controlled current source as

```
GCONST 2 3 TABLE {400/V(2, 3)} = (-400, -400)
(400, 400)
```

GCONST tries to dissipate 400 W of power regardless of the voltage across it. But for a very small voltage, the formula  $400/V(2,3)$  can lead to unreasonable values of current. TABLE limits the currents to between  $-400$  and  $+400$  A.

Note the following:

1. TABLE *must* be followed by a space.
2. The input to the table is <expression>, which must fit in one line.
3. TABLE's input *must* be in order from the lowest to the highest.

### 4.5.3 LAPLACE

The LAPLACE extension to the controlled sources of the PSpice library allows a transfer function to be described by a Laplace transform function. The general forms are:

```
E<name> N+ N- LAPLACE {<expression>} = {<transform>}
```

```
G<name> N+ N- LAPLACE {<expression>} = {<transform>}
```

The input to the transform is the value of <expression>, which follows the same rules as in Subsection 4.5.1. The <transform> is an expression in the Laplace variable,  $s$ .

#### 4.5.3.1 Typical Statements

The output voltage of a lossless integrator with a time constant of 1 msec and an input voltage  $V(5)$  can be described by

```
ERC 4 0 LAPLACE {V(5)} = {1/(1 + 0.001*sec)}
```

Frequency-dependent impedances can be simulated with a capacitor, which can be written as

```
GCAP 5 4 LAPLACE {V(5,4)} = {s}
```

Note the following:

1. LAPLACE *must* be followed by a space.
2. <expression> and <transform> must each fit on one line.
3. Voltages, currents, and TIME must not appear in a Laplace transform.
4. The LAPLACE device uses much more computer memory than does the built-in capacitor ( $C$ ) device and should be avoided if possible.

### 4.5.4 FREQ

The FREQ extension to the controlled sources of the PSpice library allows a transfer function to be described by a frequency response table. The general forms are:

```
E<name> N+ N- FREQ {<expression>} =  
+ <<(frequency)value>, <(magnitude in dB)value>,  
<(phase)value>>*
```

```
G<name> N+ N- FREQ {<expression>} =  
+ <<(frequency)value>, <(magnitude in dB)value>,  
<(phase)value>>*
```

The input to the table is the value of <expression>, which follows the same rules as those mentioned in Subsection 4.5.1. The table contains the magnitude

[in decibels (dB)] and the phase (in degrees) of the response for each frequency. Linear interpolation is performed between entries. The phase is interpolated linearly, and the magnitude is interpolated logarithmically with frequencies. For frequencies outside the table's range, the entry with the smallest (or largest) frequency is used.

#### 4.5.4.1 Typical Statements

The output voltage of a low-pass filter with input voltage  $V(2)$  can be expressed by

```
ELOWPASS 20 FREQ{V(2)} = (0, 0, 0)
+           (5kHz, 0, -57.6) (6kHz, 40, -69.2)
```

Note the following:

1. FREQ should be followed by a space.
2. <expression> must fit on one line.
3. FREQ frequencies must be in order from the lowest to the highest.

## SUMMARY

The PSpice variables can be summarized as follows:

PULSE	Pulse source PULSE (V1 V2 TD TR TF PW PER)
PWL	Piecewise linear source PWL (T1 V1 T2 V2 ... TN VN)
SIN	Sinusoidal source SIN (VO VA FREQ TD ALP THETA)
EXP	Exponential source EXP (V1 V2 TRD TRC TFD TFC)
SFFM	Single-frequency frequency modulation SFFM (VO VA FC MOD FS)
POLY	Polynomial source POLY(n) <(controlling)nodes> <(coefficients)values>
E	Voltage-controlled voltage source E<name> N+ N- NC+ NC- <(voltage gain) value>
F	Current-controlled current source F<name> N+ N- VN <(current gain) value>
G	Voltage-controlled current source G<name> N+ N- NC+ NC- <(transconductance) value>

H	Current-controlled voltage source H<name> N+ N- VN <(transresistance) value>
I	Independent current source I<name> N+ N- [dc <value>] [ac <(magnitude) value> + <(phase) value>] [(transient specifications)]
V	Independent voltage source V<name> N+ N- [dc <value>] [ac<magnitude> value> + <(phase) value>] [(transient specifications)]
VALUE	Arithmetical function E<name> N+ N- VALUE = {<expression>} G<name> N+ N- VALUE = {<expression>}
TABLE	Look-up table E<name> N+ N- TABLE {<expression>} = + <<(input) value>, <(output) value>>* G<name> N+ N- TABLE {<expression>} = + <<(input) value>, <(output) value>>*
LAPLACE	Laplace's transfer function E<name> N+ N- LAPLACE {<expression>} = {<transform>} G<name> N+ N- LAPLACE {<expression>} = {<transform>}
FREQ	Frequency response transfer function E<name> N+ N- FREQ {<expression>} = + <<(frequency) value>, <(magnitude) value>, <(phase) value>>* G<name> N+ N- FREQ {<expression>} = + <<(frequency) value>, <(magnitude) value>, <(phase) value>>*

## Suggested Reading

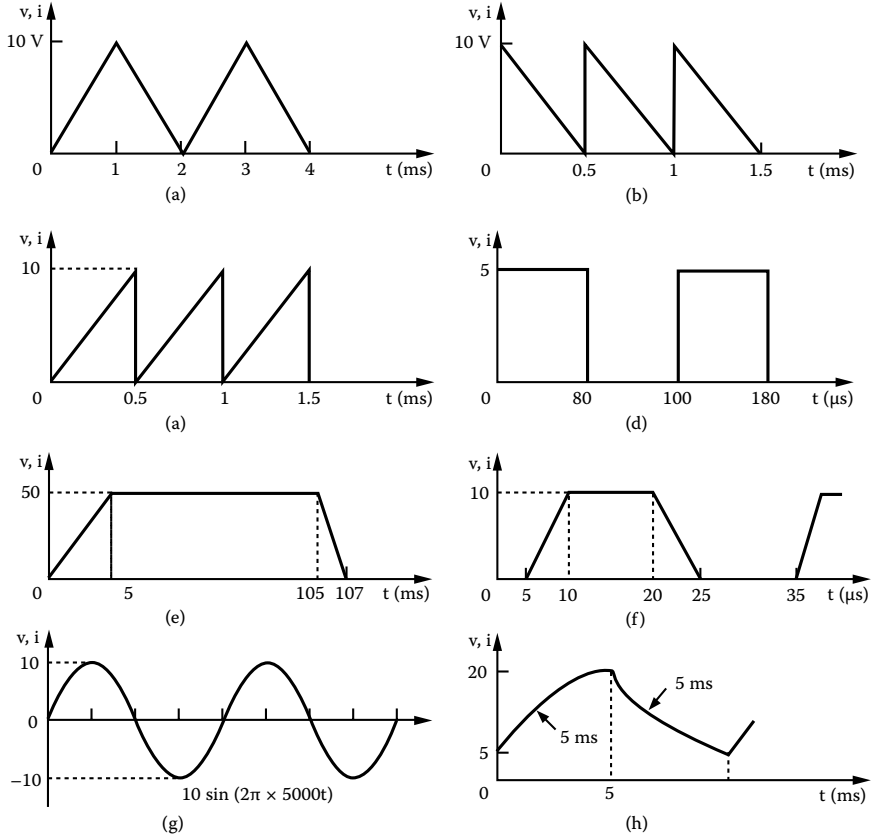
1. M.H. Rashid, *Introduction to PSpice Using OrCAD for Circuits and Electronics*, 3rd ed., Englewood Cliffs, NJ: Prentice-Hall, 2003, chap. 3 and chap. 4.
2. M.H. Rashid, *SPICE For Power Electronics and Electric Power*. Englewood Cliffs, NJ: Prentice-Hall, 1993.
3. Paul W. Tuinenga, *SPICE: A Guide to Circuit Simulation and Analysis Using PSPICE*, 3rd ed., Englewood Cliffs, NJ: Prentice-Hall, 1995.
4. MicroSim Corporation, *PSpice Manual*. Irvine, CA, 1992.

**PROBLEMS**

Write PSpice statements for the following circuits. Assume that the first node is the positive terminal, and the second node is the negative terminal.

**4.1**

The various voltage or current waveforms that are connected between nodes 4 and 5 are shown in Figure P4.1.



**FIGURE P4.1**

**4.2**

A voltage source that is connected between nodes 10 and 0 has a DC voltage of 12 V for DC analysis, a peak voltage of 2 V with a 60° phase shift for AC analysis, and a sinusoidal peak voltage of 0.1 V at 1 MHz for transient analysis.

### 4.3

A current source that is connected between nodes 5 and 0 has a DC current of 0.1 A for DC analysis, a peak current of 1 A with  $60^\circ$  phase shift for AC analysis, and a sinusoidal current of 0.1 A at 1 kHz for transient analysis.

### 4.4

A voltage source that is connected between nodes 4 and 5 is given by

$$v = 2 \sin[(2 \times 50,000t) + 5 \sin(2 \times 1000t)]$$

### 4.5

A polynomial voltage source  $Y$  that is connected between nodes 1 and 2 is controlled by a voltage source  $V_1$  connected between nodes 4 and 5. The source is given by

$$Y = 0.1V_1 + 0.2V_1^2 + 0.05V_1^2$$

### 4.6

A polynomial current source  $I$  that is connected between nodes 1 and 2 is controlled by a voltage source  $V_1$  connected between nodes 4 and 5. The source is given by

$$Y = 0.1V_1 + 0.2V_1^2 + 0.05V_1^2$$

### 4.7

A voltage source  $V_0$  that is connected between nodes 5 and 6 is controlled by a voltage source  $V_1$  and has a voltage gain of 25. The controlling voltage is connected between nodes 10 and 12. The source is expressed as  $V_0 = 25V_1$ .

### 4.8

A current source  $I_0$  that is connected between nodes 5 and 6 is controlled by a current source  $I_1$  and has a current gain of 10. The voltage through which the controlling current flows is  $V_C$ . The current source is given by  $I_0 = 10I_1$ .

### 4.9

A current source  $I_0$  that is connected between nodes 5 and 6 is controlled by a voltage source  $V_1$  between nodes 8 and 9. The transconductance is  $0.05 \Omega^{-1}$ . The current source is given by  $I_0 = 0.051V_1$ .

**4.10**

A voltage source  $V_0$  that is connected between nodes 5 and 6 is controlled by a current source  $I_1$  and has a transresistance of  $150 \Omega$ . The voltage through which the controlling current flows is  $V_C$ . The voltage source is expressed as  $V_0 = 150I_1$ .

**4.11**

A nonlinear resistance  $R$  that is connected between nodes 4 and 6 is controlled by a voltage source  $V_1$  and has a resistance of the form

$$R = V_1 + 0.2V_1^2$$

**4.12**

A nonlinear transconductance  $G_m$  that is connected between nodes 4 and 6 is controlled by a current source. The voltage through the controlling current flows is  $V_1$ . The transconductance has the form

$$G_m = V_1 + 0.2V_1^2$$

**4.13**

The  $V$ - $I$  characteristic of a diode is described by

$$I_D = I_S e^{v_D/nV_T}$$

where  $I_S = 2.2 \times 10^{-15}$  A,  $n = 1$ , and  $V_T = 26.8$  mV. Use VALUE to simulate the diode voltage between nodes 3 and 4 as a function of diode current.

**4.14**

The  $V$ - $I$  characteristic of a diode is described by

$$I_D = I_S e^{v_D/nV_T}$$

where  $I_S = 2.2 \times 10^{-15}$  A,  $n = 1$ , and  $V_T = 26.8$  mV. Use VALUE to simulate the diode current between nodes 3 and 4 as a function of diode voltage.

**4.15**

The  $V$ - $I$  characteristic of a diode is given by

$i_D$ (A)	10	20	30	40	50	100	150	500	900
$v_D$ (V)	0.55	0.65	0.7	0.75	0.8	0.9	1.0	1.3	1.4

Use TABLE to simulate the diode voltage between nodes 3 and 4 as a function of diode current.

**4.16**

The current through a varistor depends on its voltage, which is given by

$i$ (mA)	0	0.1	0.3	1	2.5	5	15	45	100	200
$v$ (V)	0	50	100	150	200	250	300	350	400	450

Use TABLE to simulate the varistor current between nodes 3 and 4 as a function of varistor current.

---

# 5 Passive Elements

The learning objectives of this chapter are modeling of:

- Passive elements
- Magnetic circuits
- Lossless transmission lines
- Controlled switches

## 5.1 INTRODUCTION

PSpice recognizes passive elements by their symbols and models. The elements can be resistors ( $R$ ), inductors ( $L$ ), capacitors ( $C$ ), or switches; they can also be magnetic. The models are necessary to take into account parameter variations (e.g., the value of a resistance depends on the operating temperature). The simulation of passive elements in PSpice requires that the following be specified:

- Modeling of elements
- Operating temperature
- $RLC$  elements
- Magnetic elements and transformers
- Lossless transmission lines
- Switches

## 5.2 MODELING OF ELEMENTS

A model that specifies a set of parameters for an element is specified in PSpice by the `.MODEL` command. The same model can be used for one or more elements in the same circuit. The various dot commands are explained in [Chapter 6](#). The general form of the model statement is

```
.MODEL M NAME TYPE (P1=V1 P2=V2  
+ P3=V3 . . . . . PN=VN [(tolerance  
specification) ] *)
```

MNAME is the name of the model and must start with a letter. Although not necessary, it is advisable to make the first letter the symbol of the element (e.g., R for resistor, L for inductor). The list of symbols for elements is shown in [Table 2.1](#). P1, P2, ... are the element parameters, and V1, V2, ... are their values,

**TABLE 5.1**  
**Type Names of Elements**

Breakout Device Name	Type Name	Resistor
Rbreak	RES	Resistor
Cbreak	CAP	Capacitor
Dcbreak	D	Diode
Lbreak	IND	Inductor
QbreakN	NPN	Bipolar junction transistor
QbreakP	PNP	Bipolar junction transistor
JbreakN	NJF	<i>n</i> -channel junction FET
JbreakP	PJF	<i>p</i> -channel Junction FET
MbreakN	NMOS	<i>n</i> -channel MOSFET
MbreakP	PMOS	<i>p</i> -channel MOSFET
Bbreak	GASFET	<i>n</i> -channel GaAs MOSFET
Sbreak	VSWITCH	Voltage-controlled switch
Wbreak	ISWITCH	Current-controlled switch
XFRM_LINEAR	None	Linear magnetic core (transformer)
XFRM_NONLINEAR	CORE	Nonlinear magnetic core (transformer)
ZbreakN	NIGBT	<i>n</i> -channel IGBT

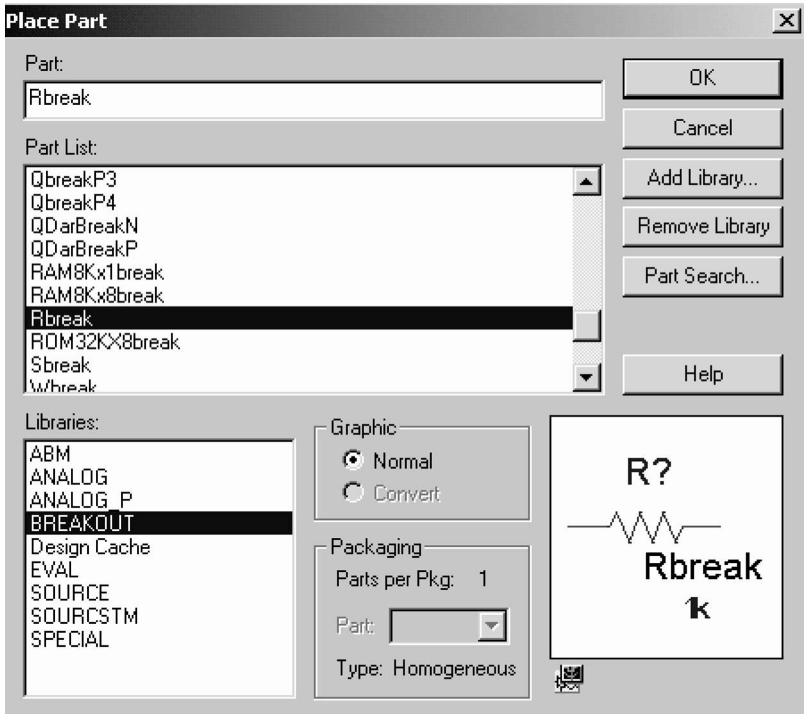
respectively. TYPE is the type name of the elements as shown in Table 5.1. An element must have the correct model type name. That is, a resistor must have the type name RES, not type IND or CAP. However, there can be more than one model of the same type in a circuit with different model names. (*tolerance specification*) is used with .MC analysis only, and it may be appended to each parameter with the format

```
[ DEV/<distribution name> <value in % from 0 to 9> ]
[ LOT/<distribution name> <value in % from 0 to 9> ]
```

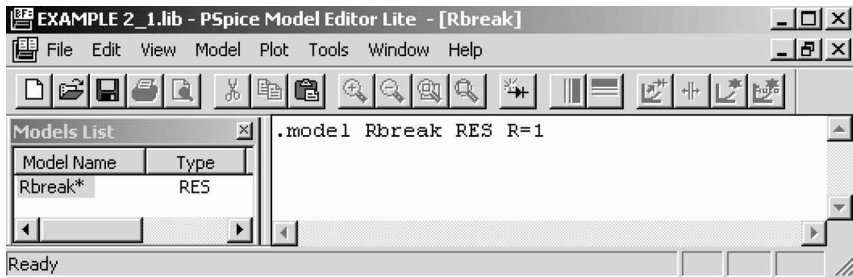
where <distribution name> is one of the following:

- UNIFORM Generates uniformly distributed deviations over the range of  $\pm$  <value>
- GAUSS Generates deviations with Gaussian distribution over the range  $\pm 4$ , and <value> specifies the  $\pm 1$  deviation

In PSpice schematics, the user can assign a model name for the breakout devices in the library breakout.slb as shown in Figure 5.1(a). The user can also specify the model parameters. PSpice can open the menu with the model name, Rbreak, as shown in Figure 5.1(b), and the model name can be changed.



(a)



(b)

FIGURE 5.1 Breakout library for models. (a) Breakout devices, (b) PSpice model editor.

### 5.2.1 SOME MODEL STATEMENTS

```
.MODEL RLOAD RES (R=1 TC1=0.02 TC2=0.005)
.MODEL RLOAD RES (R=1 DEV/GAUSS 0.5% LOT/UNIFORM10%)
.MODEL CPASS CAP (C=1 VC1=0.01 VC2=0.002 TC1=0.02 TC2=0.005)
.MODEL LFILTER IND (L=1 IL1=0.1 IL2=0.002 TC1=0.02 TC2=0.005)
```

```
.MODEL DNOM D (IS=1E-9)
.MODEL DLOAD D (IS=1E-9 DEV 0.5% LOT 10%)
.MODEL QOUT NPN (BF=50I S=1E-9)
```

## 5.3 OPERATING TEMPERATURE

The operating temperature of an analysis can be set to any value desired by the .TEMP command. The general form of the statement is

```
.TEMP <(one or more temperature) values>
```

The temperatures are in degrees Celsius. If more than one temperature is specified, the analysis is performed for each temperature. The model parameters are assumed to be measured at a nominal temperature, which is by default 27°C. The default nominal temperature of 27°C can be changed by the TNOM option in the .OPTIONS statements, which are discussed in Section 6.5.

### 5.3.1 SOME TEMPERATURE STATEMENTS

```
.TEMP 50
.TEMP 25 50
.TEMP 0 25 50 100
```

The operating temperature can be set from the analysis setup as shown in [Figure 5.2](#).

## 5.4 RLC ELEMENTS

The voltage and current relationships of resistor, inductor, and capacitor are shown in [Figure 5.3](#).

### 5.4.1 RESISTOR

The symbol of a resistor is R, and its name must start with R. The PSpice schematic is shown in [Figure 5.4\(a\)](#). Right-clicking on the element opens the menu as shown in [Figure 5.4\(b\)](#). The model parameters of resistors are shown in [Figure 5.4\(c\)](#). The resistor's name and its nominal value can be changed. Also, a tolerance value can be assigned to it.

Its description takes the general form

```
R<name> N+ N- RNAME RVALUE
```

A resistor does not have a polarity, and the order of the nodes does not matter. However, by defining N+ as the positive node and N- as the negative node, the current is assumed to flow from node N+ through the resistor to node N-.

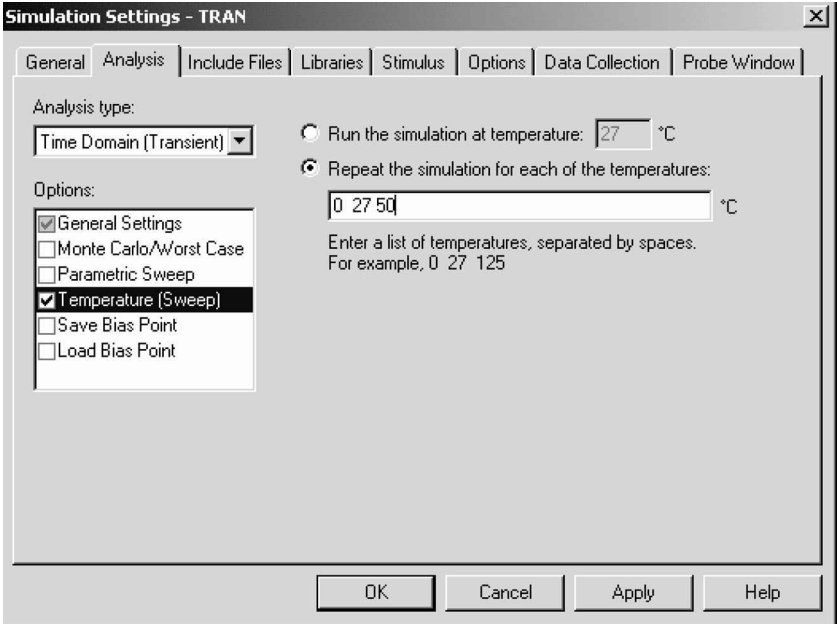


FIGURE 5.2 Setting up operating temperature.

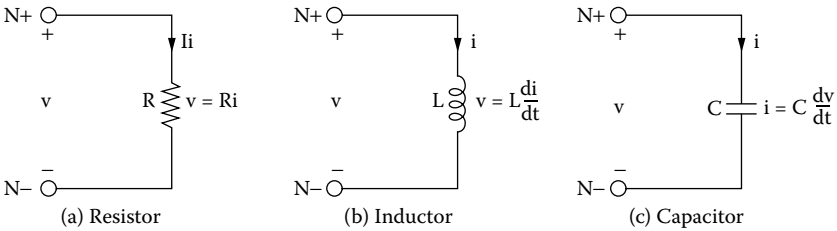


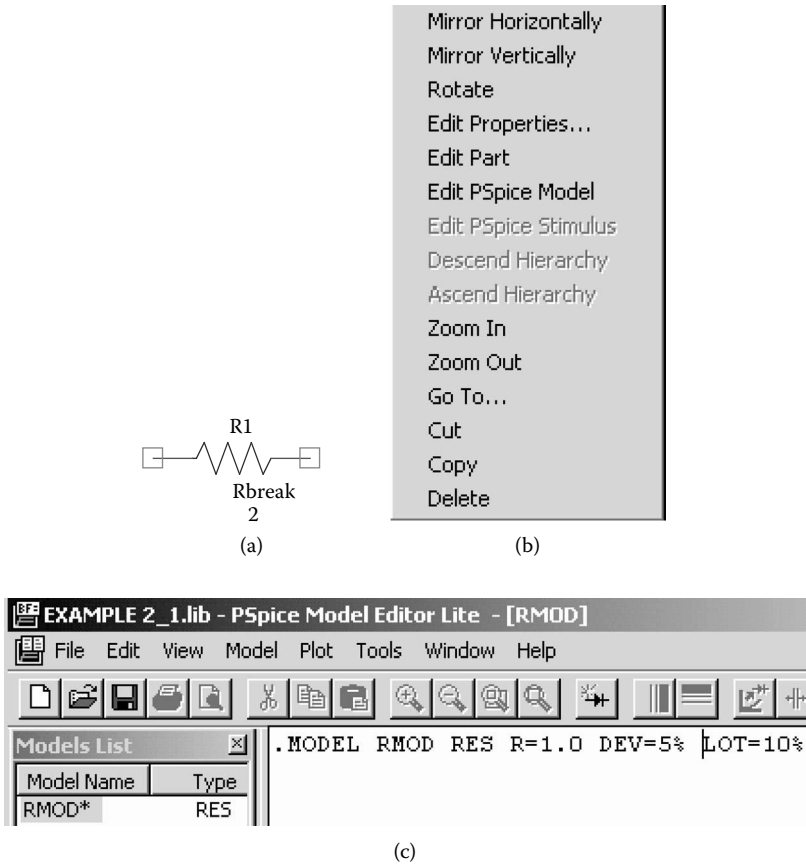
FIGURE 5.3 Voltage and current relationships.

RNAME is the model name that defines the parameters of the resistor. RVALUE is the nominal value of the resistance.

*Note:* Some versions of PSpice or SPICE do not recognize the polarity of resistors and do not allow referring currents through the resistor [e.g., I(R1)].

The model parameters are shown in Table 5.2. If RNAME is omitted, RVALUE is the resistance in ohms, and RVALUE can be positive or negative but must not be zero. If RNAME is included and TCE is not specified, the resistance as a function of temperature is calculated from

$$RES = RVALUE * R * [1 + TC1 * (T - T0) + TC2 * (T - T0)^2]$$



**FIGURE 5.4** Resistor schematics and parameters. (a) Symbol, (b) element menu, (c) resistor's model parameters.

**TABLE 5.2**  
**Model Parameters for Resistors**

Name	Meaning	Unit	Default
R	Resistance multiplier		1
TC1	Linear temperature coefficient	$^{\circ}\text{C}^{-1}$	0
TC2	Quadratic temperature coefficient	$^{\circ}\text{C}^{-2}$	0
TCE	Exponential temperature coefficient	$\%/^{\circ}\text{C}$	0

If RNAME is included and TCE is specified, the resistance as a function of temperature is calculated from

$$TCE * (T - T0)$$

$$RES = RVALUE * R * 1.01$$

where T and T0 are the operating temperature and room temperature, respectively, in degrees Celsius.

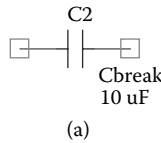
### 5.4.1.1 Some Resistor Statements

```
R1          6   5   10K
RLOAD      13  11   ARES 2MEG
.MODEL ARES RES (R=1 TC1=0.02 TC2=0.005)
RINPUT     15  14   RRES 5K
.MODEL RRES RES (R=1 TCE=2.5)
```

### 5.4.2 CAPACITOR

The symbol of a capacitor is C, and its name must start with C. The schematic of a capacitor with a breakout model is shown in Figure 5.5(a). Its value and initial condition can be changed as shown in Figure 5.5(b). The model parameters of capacitors are shown in Figure 5.5(c). The capacitor's name and its nominal value can be changed. Its description takes the general form

```
C<name> N+ N- CNAME CVALUE IC=V0
```



	Reference	Value	IC	Source Part
EXAMPLE 2_1 : PAGE1 : C2	C2	10uH	1.5V	Cbreak Normal

Models List		.model Cbreak Cap C=1 VC1=0.01 VC2=0.002
Model Name	Type	
Lbreak*	CAP	

FIGURE 5.5 Capacitor schematics and parameters. (a) Breakout model, (b) initial condition, (c) capacitor's model parameters.

**TABLE 5.3**  
**Model Parameters for Capacitors**

Name	Meaning	Unit	Default
C	Capacitance multiplier		1
VC1	Linear voltage coefficient	V <sup>-1</sup>	0
VC2	Quadratic voltage coefficient	V <sup>-2</sup>	0
TC1	Linear temperature coefficient	°C <sup>-1</sup>	0
TC2	Quadratic temperature coefficient	°C <sup>-2</sup>	0

N+ is the positive node and N- is the negative node. The voltage of node N+ is assumed positive with respect to node N- and the current flows from node N+ through the capacitor to node N-. CNAME is the model name, and CVALUE is the nominal value of the capacitor. IC defines the initial (time-zero) voltage of the capacitor, V0.

The model parameters are shown in Table 5.3. If CNAME is omitted, CVALUE is the capacitance in farads. The CVALUE can be positive or negative but must not be zero. If CNAME is included, the capacitance, which depends on the voltage and temperature, is calculated from

$$\text{CAP} = \text{CVALUE} * \text{C} * (1 + \text{VC1} * \text{V} + \text{VC2} * \text{V}^2) * [1 + \text{TC1} * (\text{T} - \text{T0}) + \text{TC2} * (\text{T} - \text{T0})^2]$$

where T is the operating temperature and T0 is the room temperature in degrees celsius.

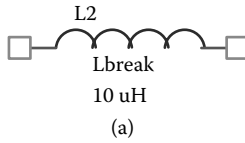
#### 5.4.2.1 Some Capacitor Statements

```
C1      6    5    10UF
CLOAD  12   11    5PF   IC=2.5V
CINPUT 15   14   ACAP   10PF
C2      20   19   ACAP   20NF   IC=1.5V
.MODEL ACAP CAP (C=1 VC1=0.01 VC2=0.002 TC1=0.02
TC2=0.005)
```

*Note:* The initial conditions (if any) apply only if the UIC (use initial condition) option is specified on the .TRAN command that is described in Section 6.9.

#### 5.4.3 INDUCTOR

The symbol of an inductor is L. Its name must start with L. The schematic of an inductor with a breakout model is shown in [Figure 5.6\(a\)](#). Its value and initial



	Reference	Value	IC	Source Part
EXAMPLE 2_1 : PAGE1 : L4	L4	10uH	0.01A	Lbreak.Normal

(b)

Models List		
Model Name	Type	
Lbreak*	IND	

```
.model Lbreak IND L=1 IL1=0.1 IL2=0.02
```

(c)

**FIGURE 5.6** Inductor schematics and parameters. (a) Symbol, (b) initial condition, (c) inductor’s model parameters.

**TABLE 5.4**  
**Model Parameters for Inductors**

Name	Meaning	Unit	Default
L	Inductance multiplier		1
IL1	Linear current coefficient	A <sup>-1</sup>	0
IL2	Quadratic current coefficient	A <sup>-2</sup>	0
TC1	Linear temperature coefficient	°C <sup>-1</sup>	0
TC2	Quadratic temperature coefficient	°C <sup>-2</sup>	0

condition can be changed as shown in Figure 5.6(b). The typical model parameters of inductors are shown in Figure 5.6(c). The inductor’s name and its nominal value can be changed.

Its description takes the general form

$$L<name> N+ N- LNAME LVALUE IC=I0$$

N+ is the positive node, and N- is the negative node. The voltage of N+ is assumed positive with respect to node N-, and the current flows from node N+ through the inductor to node N-. LNAME is the model name, and LVALUE is the nominal value of the inductor. IC defines the initial (time-zero) current I0 of the inductor.

The model parameters of an inductor are shown in Table 5.4. If LNAME is omitted, LVALUE is the inductance in henries. LVALUE can be positive or negative but must not be zero. If LNAME is included, the inductance, which depends on the current and temperature, is calculated from

$$\text{IND} = \text{LVALUE} * L * (1 + \text{IL1} * I + \text{IL2} * I^2) \\ * [1 + \text{TC1} * (T - T_0) + \text{TC2} * (T - T_0)^2]$$

where  $T$  is the operating temperature and  $T_0$  is the room temperature in degrees Celsius.

*Note:* The initial conditions (if any) apply only if the UIC (use initial condition) option is specified on the .TRAN command that is described in Section 6.9.

### 5.4.3.1 Some Inductor Statements

```
L1      6      5      10MH
LLOAD   12     11     5UH   IC=0.2MA
LLINE   15     14     LMOD   5MH
LCHOKE  20     19     LMOD   2UH   IC=0.5A
.MODEL  LMOD  IND  (L=1  IL1=0.1  IL2=0.002  TC1=0.02
TC2=0.005)
```

#### EXAMPLE 5.1 STEP RESPONSE OF AN $RLC$ CIRCUIT WITH AN INITIAL INDUCTOR CURRENT AND CAPACITOR VOLTAGE

The  $RLC$  circuit of Figure 5.7(a) is supplied with the input voltage as shown in Figure 5.7(b). Calculate and plot the transient response from 0 to 1 msec with a time increment of  $5 \mu\text{sec}$ . The output voltage is taken across resistor  $R_2$ . The results should be available for display and as hard copy by using Probe. The model parameters are, for the resistor,  $R = 1$ ,  $\text{TC1} = 0.02$ , and  $\text{TC2} = 0.005$ ; for the capacitor,  $C = 1$ ,  $\text{VC1} = 0.01$ ,  $\text{VC2} = 0.002$ ,  $\text{TC1} = 0.02$ , and  $\text{TC2} = 0.005$ ; and for the inductor,  $L = 1$ ,  $\text{IL1} = 0.1$ ,  $\text{IL2} = 0.002$ ,  $\text{TC1} = 0.02$ , and  $\text{TC2} = 0.005$ . The operating temperature is  $50^\circ\text{C}$ .

#### SOLUTION

The PSpice schematic is shown in Figure 5.8(a). The voltage marker displays the output waveform in probe at the end of the simulation. The step input voltage is

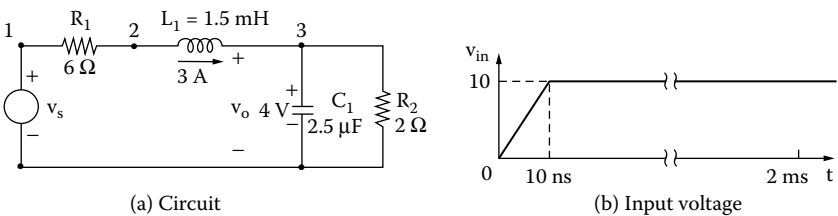
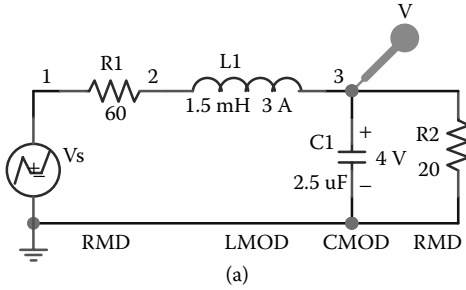


FIGURE 5.7  $RLC$  circuit for Example 5.1.



Reference	Value	AC	DC	Schematics' Source Library	Source Part	T1	T4	T2	T3	T4	T5	T6	T7	T8	T9	V1	V10	V2	V3
EXAMPLE 5.1: PAGE1: Vs	Vs		VPM	C:\MSInEv_8\BIB\SOURCE.sib	VPMV_Normal	0		10ns	10s							0		10V	10V

(b)

Model Name	Type
CMOD	CAP
LMOD	IND
RMD	RES

```
.MODEL RMD RES (R=1 TC1=0.02 TC2=0.005)
```

(c)

Model Name	Type
CMOD	CAP
LMOD	IND
RMD	RES

```
.MODEL LMOD IND (L=1 IL1=0.1 IL2=0.002 TC1=0.02 TC2=0.005)
```

(d)

Model Name	Type
CMOD	CAP
LMOD	IND
RMD	RES

```
.MODEL CMOD CAP (C=1 VC1=0.01 VC2=0.002 TC1=0.02 TC2=0.005)
```

(e)

**FIGURE 5.8** PSpice schematic for Example 5.1. (a) PSpice schematic, (b) PWL parameters, (c) RMD parameters, (d) LMOD parameters, (e) CMOD parameters.

specified by a PWL source as shown in Figure 5.8(b). The breakout devices are used to specify the parameters of model RMD for  $R_1$  and  $R_2$  as shown in Figure 5.8(c), of model LMOD for  $L_1$  as shown in Figure 5.8(d) and of model CMOD for  $C_1$  as shown in Figure 5.8(e). The Transient Analysis is set at the Analysis Setup as shown in Figure 2.6(a), and its specifications are set at the transient menu as shown in Figure 2.6(d). The operating temperature is set from the simulations setting menu as shown in Figure 5.2.

The circuit file contains the following statements:

---

### Example 5.1 RLC circuit

```

SOURCE ■ * Input step voltage represented as a PWL waveform:
VS 1 0 PWL (0 0 10NS 10V 2MS 10V)
CIRCUIT ■■ * R1 has a value of 60 Ω with model RMOD:
R1 1 2 RMOD 6
* Inductor of 1.5 mH with an initial current of 3 A
and model name LMOD:
L1 2 3 LMOD 1.5MH IC=3A
* Capacitor of 2.5 μF with an initial voltage of 4 V
and model name CMOD:
C1 3 0 CMOD 2.5UF IC=4V
R2 3 0 RMOD 2
* Model statements for resistor, inductor, and
capacitor:
.MODEL RMOD RES (R=1 TC1=0.02 TC2=0.005)
.MODEL CMOD CAP (C=1 VC1=0.01 VC2=0.002 TC1=0.02
TC2=0.005)
.MODEL LMOD IND (L=1 IL1=0.1 IL2=0.002 TC1=0.02
TC2=0.005)
* The operating temperature in 50°C.
.TEMP 50
ANALYSIS ■■■ * Transient analysis from 0 to 1 ms with a 5.μs time
increment and using initial conditions (UIC).
.TRAN 5US 1MS UIC
* Plot the results of transient analysis with the
voltage at nodes 3 and 1.
.PLOT TRAN V(3) V(1)
.PROBE V(3) V(1)
.END

```

---

The results of the simulation that are obtained by Probe are shown in [Figure 5.9](#). The inductor has an initial current of 3 A, which is taken into consideration by UIC in the .TRAN command.

## 5.5 MAGNETIC ELEMENTS AND TRANSFORMERS

The magnetic elements are mutual inductors (transformer). PSpice allows simulating two types of magnetic circuits:

- Linear magnetic circuits
- Nonlinear magnetic circuits

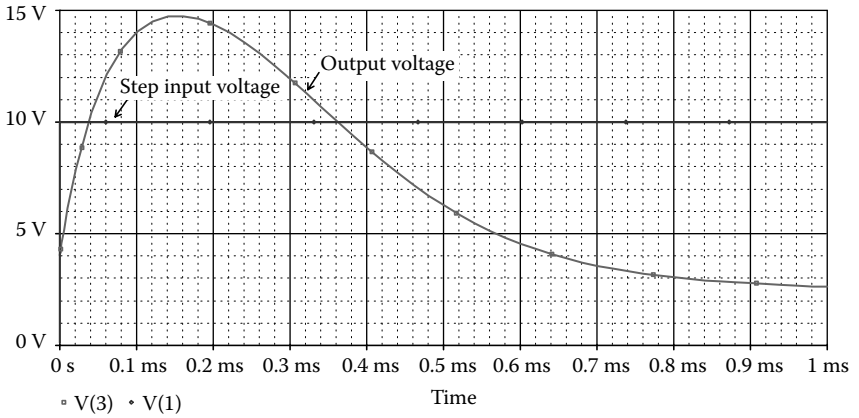


FIGURE 5.9 Transient response for Example 5.1.

### 5.5.1 LINEAR MAGNETIC CIRCUITS

The symbol of mutual coupling is  $K$ . The general form of coupled inductors is

```
K<name> L<(first inductor) name> L<(second
inductor) name>
+      <(coupling) value>
```

For linear coupled inductors,  $K<name>$  couples two or more inductors.  $<(coupling) value>$  is the coefficient of coupling,  $k$ . The value of coefficient of coupling must be greater than 0 and less than or equal to 1:  $0 < k \leq 1$ .

The inductors can be coupled in either order positively or negatively as shown in Figure 5.10(a) and Figure 5.10(b), respectively. In terms of the dot convention

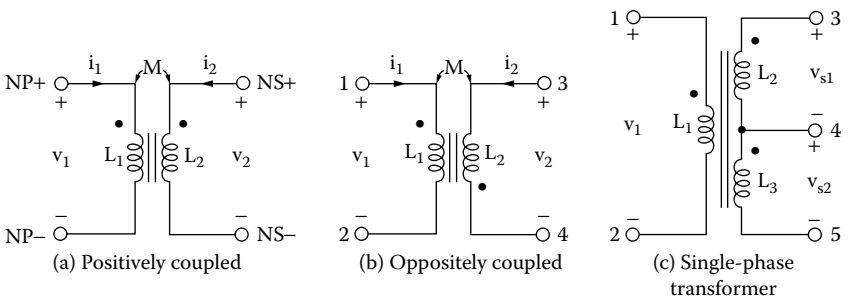


FIGURE 5.10 Coupled inductors. (a) Positively coupled, (b) negatively coupled, (c) single-phase transformer.

shown in [Figure 5.10\(a\)](#), PSpice assumes a dot on the first node of each inductor. The mutual inductance is determined from

$$M = k\sqrt{L_1L_2}$$

In the time domain, the voltages of coupled inductors are expressed as

$$v_1 = L_1 \frac{di_1}{dt} + M \frac{di_2}{dt}$$

$$v_2 = M \frac{di_1}{dt} + L_2 \frac{di_2}{dt}$$

In the frequency domain, the voltages are expressed as

$$V_1 = j\omega L_1 I_1 + j\omega M I_2$$

$$V_2 = j\omega M I_1 + j\omega L_2 I_2$$

where  $\omega$  is the frequency in rad/sec.

Some coupled-inductor statements are

```
KTR LA LB 0.9
```

```
KIND L1 L2 0.98
```

The PSpice schematic for coupled inductors is shown in [Figure 5.11\(a\)](#). The K-linear in the analog.slb library that can couple up to six inductors is shown in [Figure 5.11\(b\)](#) with two inductors  $L_1$  and  $L_2$ .

The coupled inductors of [Figure 5.10\(a\)](#) can be written as a single-phase transformer (with  $k = 0.9999$ ):

```
* PRIMARY
```

```
L1      1  2  0.5MH
```

```
* SECONDARY
```

```
L2      3  4  0.5MH
```

```
* MAGNETIC COUPLING
```

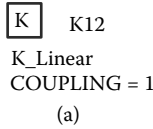
```
KXFRMER L1 L2 0.9999
```

If the dot in the second coil is changed as shown in [Figure 5.10\(b\)](#), the coupled inductors are written as

```
L1      1  2  0.5MH
```

```
L2      4  3  0.5MH
```

```
KXFRMER L1 L2 0.9999
```



		Reference	Value	K13	COUPLING	L1	L2	L3	L4	L5	L6
1	+	EXAMPLE 5_2 : PAGE1 : K12	K12	K_Linear	0.999	L1	L2				

(b)

**FIGURE 5.11** Coupled inductors with K-linear. (a) Symbol, (b) parameters for K-linear.

A transformer with a single primary coil and center-tapped secondary as shown in [Figure 5.10\(c\)](#) can be written as

```
* PRIMARY
L1 1 2 0.5MH

* SECONDARY
L2 3 4 0.5MH
L3 4 5 0.5MH

* MAGNETIC COUPLING
K12 L1 L2 0.9999
K13 L1 L3 0.9999
K23 L2 L3 0.9999
```

The three statements above (K12, K13, K23) can be written in PSpice as  
 KALL L1 L2 L3 0.9999

*Note the following:*

1. The name Kxx need not be related to the names of the inductors it is coupling. However, it is a good practice, because it is convenient to identify the inductors involved in the coupling.
2. The polarity (or dot) is determined by the order of the nodes in the L ... statements and not by the order of the inductors in the K ... statement [e.g., (K12 L1 L2 0.9999) has the same result as (K12 L2 L1 0.9999)].

**EXAMPLE 5.2 FINDING THE RMS CURRENTS AND THE FREQUENCY PLOT OF A COUPLED-INDUCTOR CIRCUIT**

A circuit with two coupled inductors is shown in [Figure 5.11](#). The input voltage is 120 V peak. Calculate the magnitude and phase of the output current for frequencies

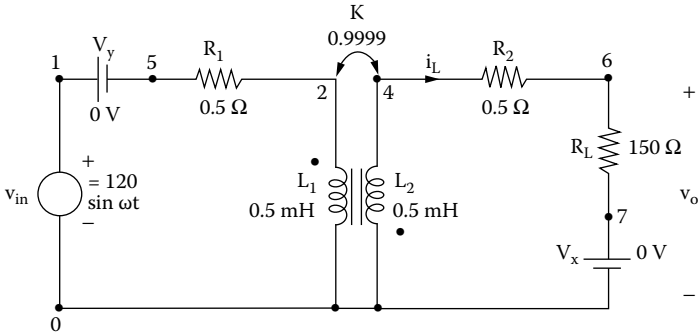


FIGURE 5.12

from 60 to 120 Hz with a linear increment. The total number of points in the sweep is 2. The coefficient of coupling for the transformer is 0.999.

### SOLUTION

It is important to note that the primary and the secondary have a common node. Without this common node, PSpice will give an error message because there is no DC path from the nodes of the secondary to the ground.

The PSpice schematic is shown in Figure 5.12(a). K-linear couples L1 and L2 with a coupling of 0.9999. The voltage marker displays the output waveforms in Probe at the end of the simulation. The PSpice plot of the input and output voltages are shown in Figure 5.13(b). The break frequency is  $f_b = 79.81$  Hz at 84.906 V (70.7%) of the high-frequency value of 120 V.

The circuit file contains the following statements:

---

### Example 5.2 Coupled linear inductors

**SOURCE** ■ \* Input voltage is 120 V peak and  $0^\circ$  phase for ac analysis:

```
VIN 1 0 AC 120V
```

**CIRCUIT** ■■ R1 5 2 0.5

\* A dummy voltage source of  $V_Y = 0$  is added to measure the load current:

```
VY 1 5 DC 0V
```

\* The dot convention is followed in inductors L1 and L2:

```
L1 2 0 1mH
```

```
L1 0 4 0.5mH
```

\* Magnetic coupling coefficient is 0.999. The order of L1 and L2 is

```

* not significant.
K12 L1 L2 0.999
R2 4 6 0.5
RL 6 7 150
* A dummy voltage source of VX = 0 is added to measure
the load current:
VX 7 0 DC 0V
ANALYSIS ■■■ * Ac analysis where the frequency is varied linearly
from 60 Hz to 120 Hz with two points:
ACLIN260HZ120HZ
* Print the magnitude and phase of output current.
Some versions of
* Pspice and SPICE do not permit reference to currents
through resistors [e.g., IM(RL), IP(RL)].
.PRINT AC IM(VY) IP(VY) IM(RL) IP(RL)
; Prints to the output file
.END

```

The transformer is considered to be linear and its inductances remain constant. The results of the simulation, which are stored in output file EX5.2.OUT, are

FREQ	IM(VY)	IP(VY)	IM(RL)	IP(RL)	V(4)	V(2)
6.000E+01	1.915E+02	-3.699E+01	3.389E-01	-1.271E+02	5.100E+01	7.220E+01
1.200E+02	1.325E+02	-5.635E+01	4.689E-01	-1.465E+02	7.056E+01	9.989E+01

*Note:* PSpice (that is, the net list using PSpice A/D) is better suited to printing the magnitudes and phases of voltages. Schematics is, however, better suited to drawing the schematics and plots of voltages and currents.

### 5.5.2 NONLINEAR MAGNETIC CIRCUITS

For a nonlinear inductor, the general form is

```

K<name> L<(inductor) name> <(coupling) value>
+ <(model) name> [(size) value]

```

For an iron-core transformer,  $k$  is very high, greater than 0.999. The model type name for a nonlinear magnetic inductor is CORE, and the model parameters are shown in Table 5.5. [(size) value] scales the magnetic cross section and defaults to 1. It represents the number of lamination layers, so that only one model statement can be used for a particular lamination type of core.

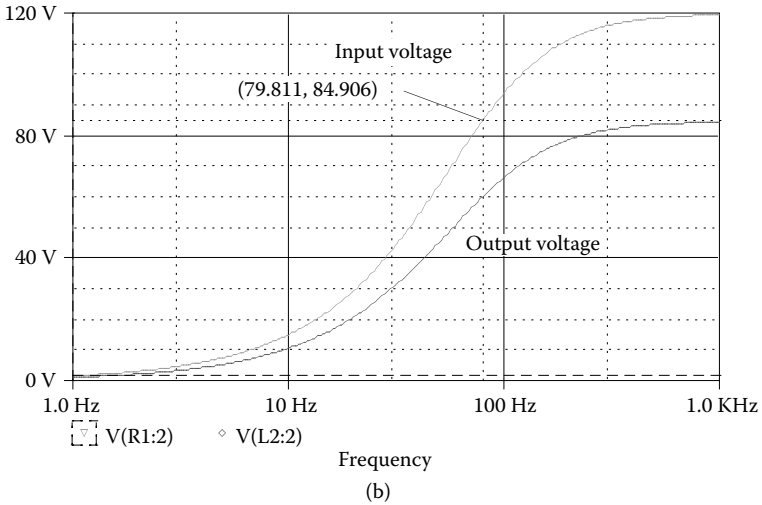
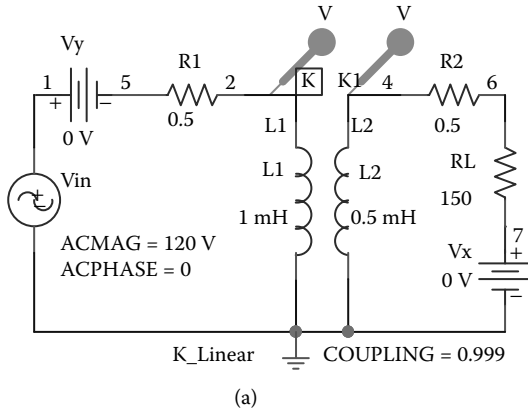


FIGURE 5.13 PSpice schematic for Example 5.2. (a) Schematic, (b) frequency responses.

If the <(model) name> is specified, the mutual coupling inductor becomes a nonlinear magnetic core and the inductor specifies the number of turns instead of the inductance. The list of the coupled inductors may be just one inductor.

The magnetic core’s  $B - H$  characteristics are analyzed using the Jiles–Atherton model [2].

If the inductors of Figure 5.10(a) use the nonlinear core, the statements would be as follows:

```
* Inductor  $L_1$  of 100 turns:
L1 1 2 100

* Inductor  $L_2$  of 10 turns:
```

**TABLE 5.5**  
**Model Parameters for Nonlinear Magnetic**

Name	Meaning	Unit	Default
AREA	Mean magnetic cross section	cm <sup>2</sup>	0.1
PATH	Mean magnetic path length	cm	1.0
GAP	Effective air-gap length	cm	0
PACK	Pack (stacking)		1.0
MS	Magnetic saturation	A/m	1E + 6
A	Shape parameter		1E + 3
C	Domain wall-flexing constant		0.2
K	Domain wall-pinning constant		500

L2 3 4 10

\* Nonlinear coupled inductors with model CMOD:

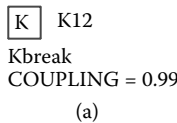
K12 L1 L2 0.9999 CMOD

\* Model for the nonlinear inductors:

.MODEL CMOD CORE (AREA=2.0 PATH=62.8 GAP=0.1 PACK=0.98)

In PSpice schematics, the nonlinear magnetic parameters can be described by using a K-break coupling as shown in Figure 5.14(a). The K-nonlinear model in the breakout.slb library that can couple up to six inductors is shown in Figure 5.14(b) with two inductors L<sub>1</sub> and L<sub>2</sub>.

The model parameters can be adjusted to specify a B–H characteristic. The nonlinear magnetic model uses MKS (metric) units. However, the results for Probe are converted to gauss and oersted and may be displayed using B(Kxx) and H(Kxx). The B–H curve can be drawn by a transient run with a slowly rising current through a test inductor and then by displaying B(Kxx) against H(Kxx).



	Reference	Value	COUPLING	L1	L2	L3	L4	L5	L6
SCHEMATIC1 : PAGE1 : K12	K12	Kbreak	0.99	100	10				

(b)

**FIGURE 5.14** Nonlinear coupled inductors. (a) Symbol, (b) parameters for K-nonlinear.

Characterizing core materials may be carried out by trial by using PSpice and Probe. The procedures for setting parameters to obtain a particular characteristic are as follows:

1. Set the domain wall-pinning constant  $K=0$ . The curve should be centered in the  $B$ - $H$  loop. The slope of the curve at  $H=0$  should be approximately equal to that when it crosses the  $H$  axis at  $B=0$ .
2. Set the magnetic saturation  $MS = B_{\max}/0.01257$ .
3. ALPHA sets the slope of the curve. Start with the mean field parameter  $ALPHA = 0$ , and then vary its value to get the desired slope of the curve. It may be necessary to change  $MS$  slightly to get the desired saturation value.
4. Change  $K$  to a nonzero value to create the desired hysteresis.  $K$  affects the opening of the hysteresis loop.
5. Set  $C$  to obtain the initial permeability. Probe displays the permeability, which is  $\Delta B/\Delta H$ . Because Probe calculates differences, not derivatives, the curves will not be smooth. The initial value of  $\Delta B/\Delta H$  is the initial permeability.

*Note:* A nonlinear magnetic model is not available in SPICE2.

### EXAMPLE 5.3 PLOTTING THE NONLINEAR $B$ - $H$ CHARACTERISTIC OF A MAGNETIC CIRCUIT

The coupled inductors of Figure 5.10(a) are nonlinear. The parameters of the inductors are  $L_1 = 200$  turns,  $L_2 = 100$  turns, and  $k = 0.9999$ . Plot the  $B$ - $H$  characteristic of the core from the results of transient analysis if the input current is varied very slowly from 0 to  $-15$  A,  $+15$  to  $-15$  A, and  $-15$  to  $+15$  A. A load resistance of  $R_L = 1$  k $\Omega$  is connected to the secondary of the transformer. The model parameters of the core are  $AREA = 6.0$ ,  $PATH = 82.73$ ,  $GAP = 0.1$ ,  $MS = 1.6E + 6$ ,  $ALPHA = 1E - 3$ ,  $A = 1E + 3$ ,  $C = 0.5$ , and  $K = 1500$ .

#### SOLUTION

The PSpice schematic is shown in Figure 5.15(a). K-break couples L1 and L2 with a coupling of 0.9999 and its model parameters are specified in K\_CMOD. The PSpice plots of the instantaneous input current and flux density are shown in Figure 5.15(b).

The circuit file for the coupled inductors in Figure 5.4(a) would be:

---

### Example 5.3 Typical $B$ - $H$ characteristic

**SOURCE** ■ \* PWL waveform for transient analysis:

```
IN 1 0 PWL (0 0 1 -15 2 15 3 -15)
```

**CIRCUIT** ■■ \* Inductors represent the number of turns:

```
L1 1 0 200
```

```

L2  2  0  1000
R2  2  0  1000                ; Load resistance
* Coupled inductors with k = 0.999 and model CMOD:
K12 L1 L2  0.9999  CMOD
* Model parameters for CMOD:
.MODEL CMOD CORE (AREA=2.0 PATH=62.73 GAP=0.1 MS=1.6E+6
+ A = 1E + 3C = 0.5K = 1500)

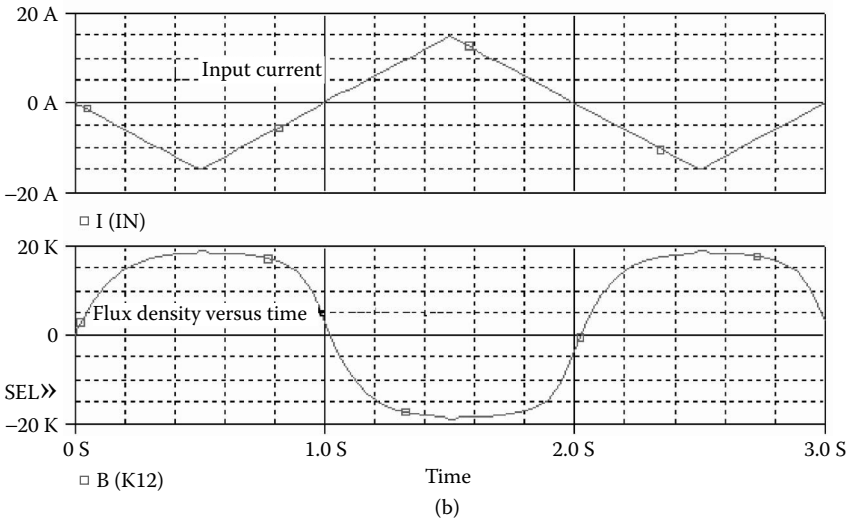
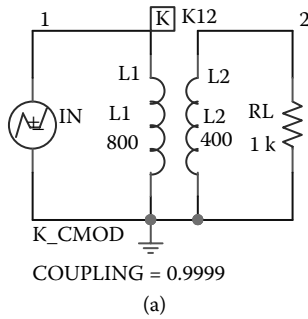
```

**ANALYSIS** ■■■ \* Transient analysis from 0 to 3 s in steps of 0.05 s:

```

.TRAN 0.05S 3S
.PROBE
.END

```



**FIGURE 5.15** PSpice schematic for Example 5.3. (a) Schematic, (b) instantaneous input current and flux density.

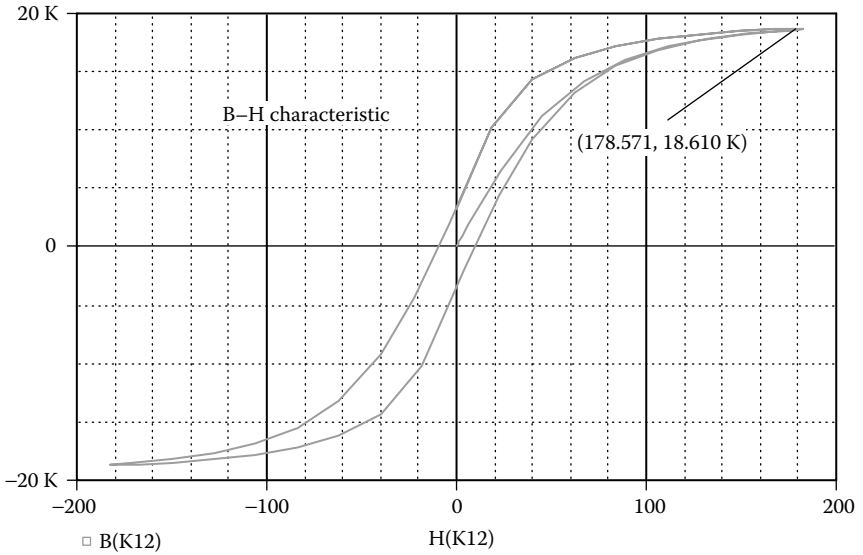


FIGURE 5.16 Typical  $B-H$  characteristic.

The  $B-H$  characteristic obtained by Probe is shown in Figure 5.16.

The plot of the flux density,  $B(K12)$ , against the magnetic field,  $H(K12)$ , is shown in Figure 5.16, which gives  $B_{max} = 178.57$  and  $H_{max} = 18.61$  k. Note that by using the Probe menu, the  $x$  axis has been changed to  $H(K12)$ .

**EXAMPLE 5.4 FINDING THE OUTPUT VOLTAGE AND CURRENT OF A COUPLED-INDUCTOR WITH A NONLINEAR MAGNETIC CORE**

The coupled inductor in Example 5.2 is replaced by a nonlinear core with the  $B-H$  characteristic shown in Figure 5.6. This is shown in Figure 5.17. The parameters of the inductors are  $L_1 = 200$  turns,  $L_2 = 100$  turns, and  $k = 0.9999$ . The input voltage

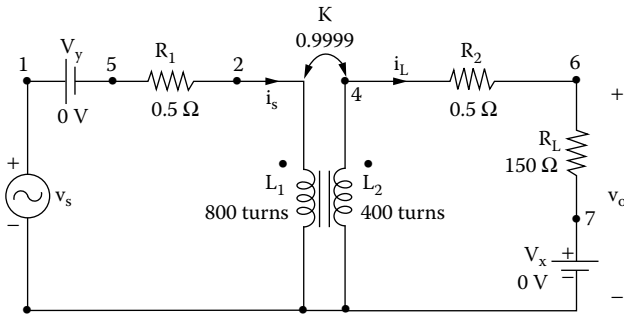


FIGURE 5.17 Circuit with nonlinear coupled inductors.

is  $v_s = 170 \sin(2\pi \times 60t)$ . Plot the instantaneous values of the secondary voltage and current from 0 to 35 msec with a 10- $\mu$ sec increment. The results should be available for display and as hard copy by using Probe. The model parameters of the core are AREA = 6.0, PATH = 82.73, GAP = 0.1, MS = 1.6E + 6, ALPHA = 1E - 3, A = 1E + 3, C = 0.5, and K = 1500.

### SOLUTION

The primary and the secondary have a common node. Without this common node, PSpice will give an error message because there is no DC path from the nodes of the secondary to the ground. The PSpice schematic is shown in Figure 5.18(a). The K-break couples L1 and L2 with a coupling of 0.9999 and its model parameters are specified in K\_CMOD as shown in Figure 5.18(b). The voltage and current markers display the output waveforms in probe at the end of the simulation.

The circuit file contains the following statements:

---

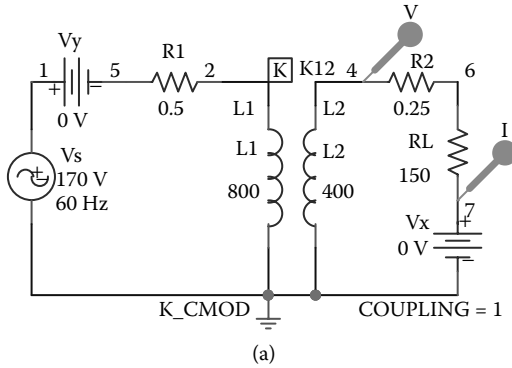
### Example 5.4 Nonlinear coupled inductors

```

SOURCE   ■ * Input sinusoidal voltage of 170 V peak and 0° phase:
              VS 1 0 SIN (0 170V 60HZ)
CIRCUIT  ■■ * A dummy voltage source of VY = 0 is added to measure
              the load current:
              VY 1 5 DC 0V
              R1 5 2 0.5
              * Inductors represent the number of turns:
              L1 2 0 800
              L2 4 0 400
              * Coupled inductors with k = 0.9999 and model CMOD:
              K12 L1 L2 0.9999 CMOD
              * Model parameters for CMOD:
              .MODEL CMOD CORE (AREA=2.0 PATH=62.73 GAP=0.1 MS=1.6E+6
              +      A=1E+3 C=0.5 K=1500)
              R2 4 6 0.5
              RL 6 7 150
              * A dummy voltage source of VX = 0 is added to measure
              the load current:
              VX 7 0 DC 0V
ANALYSIS ■■■ * Transient analysis from 0 to 35 ms with a 100- $\mu$ s
              increment:
              .TRAN 10US 35MS
              * Print the output voltage and current.
              .PRINT TRAN V(4) I(VX)      ; Prints in the output file
              .PROBE                       ; Graphics post-processor
              .END

```

---



Models List			.MODEL K_CMOD CORE (AREA=6.0 PATH=82.73 GAP=0.1 MS=1.6E+6
Model Name	Type		+ A=1E+3 C=0.5 K=1500)
K_CMOD	Core		

FIGURE 5.18 PSpice schematic for Example 5.4. (a) Schematic, (b) model parameters for K-CMOD.

The results of the simulation that are obtained by Probe are shown in Figure 5.19. Because of the nonlinear  $B-H$  characteristic, the input and output currents will become nonlinear and contain harmonics, depending on the number of turns and the parameters of the magnetic core.

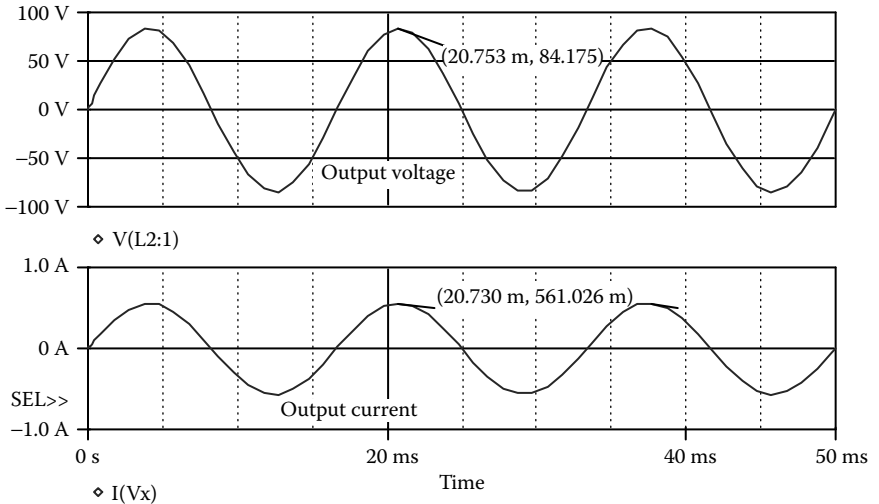


FIGURE 5.19 Transient response for Example 5.4.

## 5.6 LOSSLESS TRANSMISSION LINES

The symbol of a lossless transmission line is T. A transmission line has two ports: input and output. The general form of a transmission line is

```
T<name> NA+ NA- NB+ NB- Z0=<value> [TD=<value>]
+      [F=<value> NL=<value>]
```

T<name> is the name of the transmission line. NA+ and NA- are the nodes at the input port. NB+ and NB- are the nodes at the output port. NA+ and NB+ are defined as the positive nodes. NA- and NB- are defined as the negative nodes. The positive current flows from NA+ to NA- and from NB+ to NB-. Z0 is the characteristic impedance.

The length of the line can be expressed in either of two forms: (1) the transmission delay TD may be specified or (2) the frequency F may be specified together with NL, which is the normalized electrical length of the transmission line with respect to wavelength in the line at frequency F. If the frequency F is specified but not NL, the default value of NL is 0.25; that is, F has the quarter-wave frequency. It should be noted that one of the options for expressing the length of the line must be specified. That is, TD or F must be specified. The block diagram of transmission line is shown in [Figure 5.20\(a\)](#).

Some transmission statements are

```
T1  1  2  3  4  Z0=50  TD=10NS
T2  4  5  6  7  Z0=50  F=2MHZ
TTRM 9 10 11 12 Z0=50  F=2MHZ  NL=0.4
```

The coaxial line shown in [Figure 5.20\(b\)](#) can be represented by two propagating lines: the first line (T1) models the inner conductor with respect to the shield, and the second line (T2) models the shield with respect to the outside:

```
T1  1  2  3  4  Z0=50  TD=1.5NS
T2  2  0  4  0  Z0=150  TD=1NS
```

*Note:* During the transient analysis (.TRAN), the internal time step of PSpice is limited to be no more than half of the smallest transmission delay. Thus, short transmission lines will cause long run times.

## 5.7 SWITCHES

PSpice allows simulating a special type of switch, as shown in [Figure 5.21](#), whose resistance varies continuously depending on the voltage or current. When the switch  $S_1$  is on, the resistance is  $R_{ON}$ ; when it is off, the resistance becomes  $R_{OFF}$ . The three types of switches permitted in PSpice are:

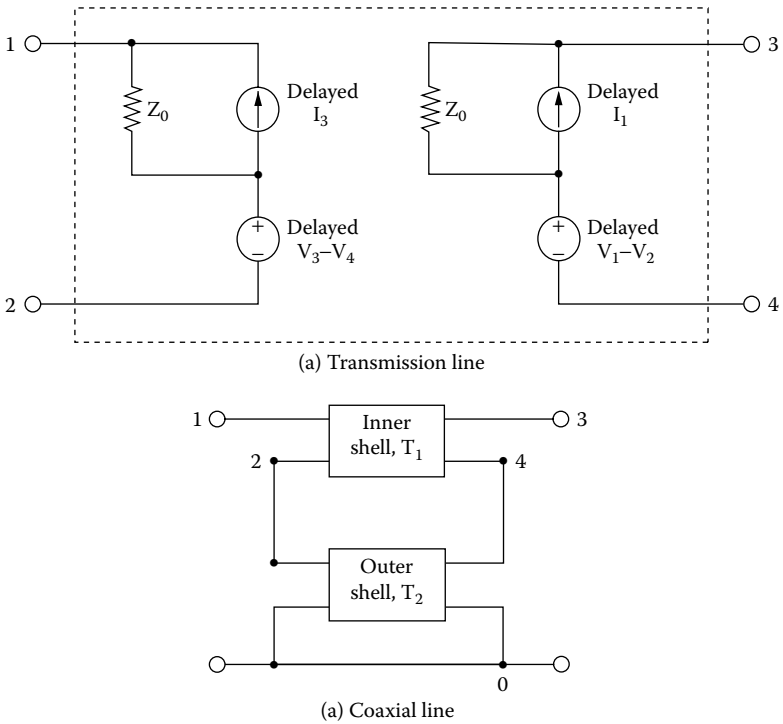


FIGURE 5.20 Transmission line. (a) Transmission line, (b) coaxial line.

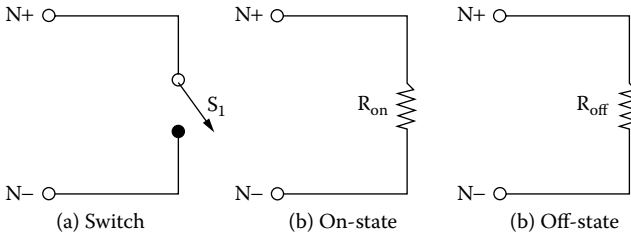


FIGURE 5.21 Switch with a variable resistance. (a) Switch, (b) on state, (c) off state.

- Voltage-controlled switches
- Current-controlled switches
- Time-dependent switches

Note: The voltage- and current-controlled switches are not available in SPICE2. However, they are available in SPICE3.

### 5.7.1 VOLTAGE-CONTROLLED SWITCH

The symbol of a voltage-controlled switch is S. Its name must start with S, and it takes the general form

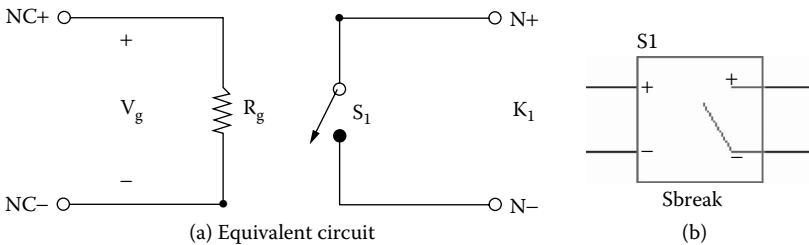
S<name> N+ N- NC+ NC- SNAME

N+ and N- are the two nodes of the switch. The current is assumed to flow from N+ through the switch to node N-. NC+ and NC- are the positive and negative nodes of the controlling voltage source, as shown in Figure 5.22(a). SNAME is the model name. The resistance of the switch varies depending on the voltage across the switch. The type name for a voltage-controlled switch is VSWITCH, and the model parameters are shown in Table 5.6. The PSpice schematic is shown in Figure 5.22(b).

The voltage-controlled switch statement is

```
S1 6 5 4 0 SMOD
```

```
.MODEL SMOD VSWITCH (RON=0.5 ROFF=10E+6 VON=0.7
VOFF=0.0)
```



**FIGURE 5.22** Voltage-controlled switch. (a) Positive and negative nodes, (b) PSpice schematic.

**TABLE 5.6**  
Model Parameters for Voltage-Controlled Switch

Name	Meaning	Unit	Default
VON	Control voltage for on-state	V	1.0
VOFF	Control voltage for off-state	V	0
RON	On resistance	W	1.0
ROFF	Off resistance	W	10 <sup>6</sup>

Note the following

1.  $R_{ON}$  and  $R_{OFF}$  must be greater than zero and less than  $1/GMIN$ . The value of  $GMIN$  can be defined as an option as described in .OPTIONS command in Section 6.5. The default value of conductance,  $GMIN$ , is  $1E - 12 \Omega^{-1}$ .
2. The ratio of  $R_{OFF}$  to  $R_{ON}$  should be less than  $1E + 12$ .
3. The difficulty due to the high gain of an ideal switch can be minimized by choosing the value of  $R_{OFF}$  to be as high as permissible and that of  $R_{ON}$  to be as low as possible compared with other circuit elements, within the limits of allowable accuracy.

### EXAMPLE 5.5 STEP RESPONSE WITH A VOLTAGE-CONTROLLED SWITCH

A circuit with a voltage-controlled switch is shown in Figure 5.23. The input voltage is  $v_s = 200 \sin(2000\pi t)$ . Plot the instantaneous voltage at node 3 and the current through the load resistor  $R_L$  for a duration of 0 to 1 msec with an increment of 5  $\mu$ sec. The model parameters of the switch are  $R_{ON} = 5M$ ,  $R_{OFF} = 10E + 9$ ,  $V_{ON} = 25M$ , and  $V_{OFF} = 0.0$ . The results should be available for display by using Probe.

### SOLUTION

The PSpice schematic is shown in Figure 5.24(a). The gain of the voltage-controlled voltage source E1 is set to 0.1. The voltage and current markers display the output waveform in probe at the end of the simulation. The input voltage is specified by a sinusoidal source. The breakout voltage controlled switch (S1) is used to specify the switch model SMOD as shown in Figure 5.24(b) and its model parameters are  $R_{ON} = 5M$ ,  $R_{OFF} = 10E+9$ ,  $V_{ON} = 25M$ , and  $V_{OFF} = 0$ .

The voltage source  $VX = 0$  V is inserted to monitor the output current. The listing of the circuit file is as follows:

---

### Example 5.5 Voltage-controlled switch

```

SOURCE   ■ * Sinusoidal input voltage of 200 V peak with 0° phase
          delay:
          VS 1 0 SIN (0 200V 1KHZ)
CIRCUIT  ■■ RS 1 2 1000HM
          R1 2 0 100KOHM
          * Voltage-controlled voltage source with a voltage gain
          of 0.1:
          E1 3 0 2 0 0.1
          RL 4 5 20HM
          * Dummy voltage source of VX = 0 to measure the load
          current:
          VX 5 0 DC 0V

```

\* Voltage-controlled switch controlled by voltage across nodes 3 and 0:

S1 3 4 3 0 SMOD

\* Switch model descriptions:

.MODEL SMOD VSWITCH (RON=5m ROFF=10E+9 VON=25m VOFF=0.0)

**ANALYSIS** ■■■

\* Transient analysis from 0 to 1 ms with a 5.  $\mu$ s increment:

.TRAN 5US 1MS

\* Plot the current through VS and the input voltage.

.PLOT TRAN V(3) I(VX) ; On the output file

.PROBE ; Graphics post-processor

.END

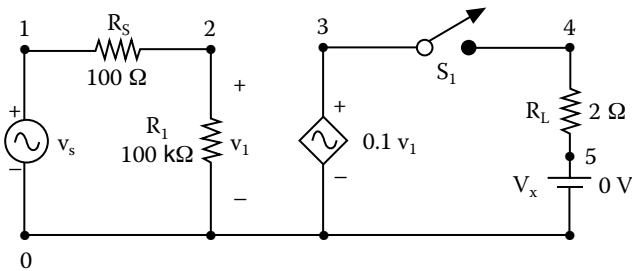
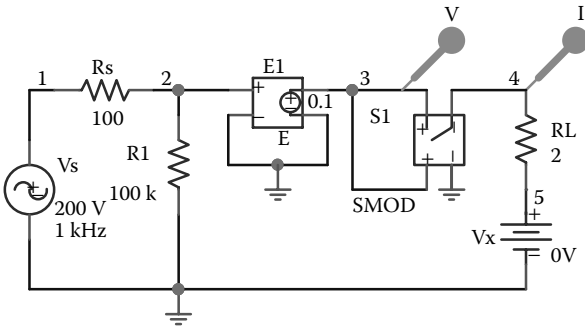


FIGURE 5.23 Circuit with a voltage-controlled switch.



(a)

Models List		.MODEL SMOD VSWITCH (RON=5m ROFF=1E9 VON=25m VOFF=0)
Model Name	Type	
SMOD	VSwitch	

(b)

FIGURE 5.24 PSpice schematic for Example 5.5. (a) PSpice schematic, (b) specifications of VSWITCH.

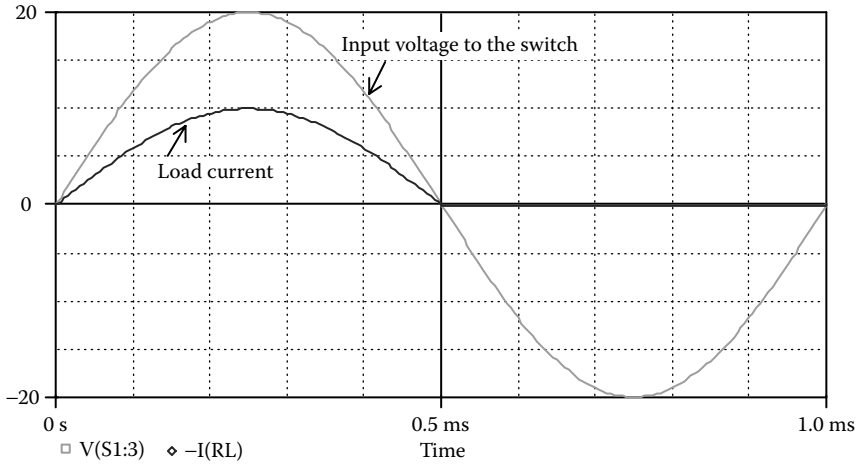


FIGURE 5.25 Transient response for Example 5.5.

The results of the simulation that are obtained by Probe are shown in Figure 5.25, which is the output of a diode rectifier. Switch  $S_1$  behaves as a diode.

### 5.7.2 CURRENT-CONTROLLED SWITCH

The symbol of a current-controlled switch is W. The name of the switch must start with W, and it takes the general form

W<name> N+ N- VN WNAME

N+ and N- are the two nodes of the switch. VN is a voltage source through which the controlling current flows as shown in Figure 5.26(a). WNAME is the model name. The resistance of the switch depends on the current through the switch. The type name for a current-controlled switch is ISWITCH and the model parameters are shown in Table 5.7. The PSpice schematic is shown in Figure 5.26(b).

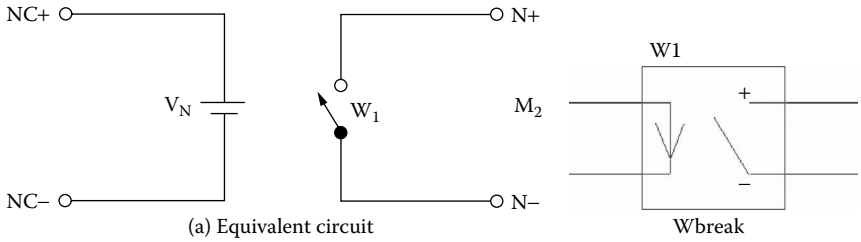
The current-controlled switch statement is

```
W1      6  5  VN  RELAY
.MODEL RELAY ISWITCH (RON=0.5 ROFF=10E+6 ION=0.07
IOFF=0.0)
```

*Note:* The current through voltage source VN controls the switch. The voltage source VN must be an independent source, and it can have a finite value or zero. The limitations of the parameters are similar to those for the voltage-controlled switch.

#### EXAMPLE 5.6 TRANSIENT RESPONSE OF AN LC CIRCUIT WITH A CURRENT-CONTROLLED SWITCH

A circuit with a current-controlled switch is shown in Figure 5.27. Plot the capacitor voltage and the inductor current for a duration of 0 to 160  $\mu$ sec with an increment



**FIGURE 5.26** Current-controlled switch. (a) Equivalent circuit, (b) PSpice schematic.

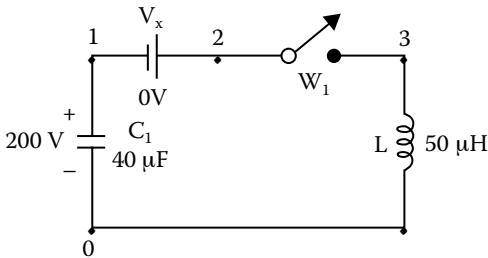
**TABLE 5.7**  
**Model Parameters for Current-Controlled Switch**

Name	Meaning	Unit	Default
ION	Control current for on-state	A	1E-3
IOFF	Control current for off-state	A	0
RON	On resistance	W	1.0
ROFF	Off resistance	W	10 <sup>6</sup>

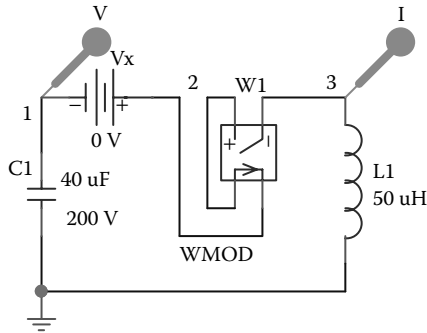
of 1  $\mu$ sec. The model parameters of the switch are  $RON = 1E + 6$ ,  $ROFF = 0.001$ ,  $ION = 1MA$ , and  $IOFF = 0$ . The results should be available for display by using Probe.

**SOLUTION**

The PSpice schematic is shown in Figure 5.28(a). The voltage and current markers display the output waveforms in Probe at the end of the simulation. The initial voltage on the capacitor C1 specifies the input source. The breakout current-controlled switch (W1) is used to specify the parameters of the switch model WMOD as shown in Figure 5.28(b) and its model parameters are  $ION = 1MA$ ,  $IOFF = 0$ ,  $RON = 1E + 6$ , and  $ROFF = 0.01$ .



**FIGURE 5.27** Circuit with a current-controlled switch.



(a)

Models List		.MODEL WMOD ISWITCH (RON=1E6 ROFF=0.001 ION=1MA IOFF=0)
Model Name	Type	
WMOD	ISwitch	

(b)

**FIGURE 5.28** PSpice schematic for Example 5.6. (a) PSpice schematic, (b) specifications of ISWITCH.

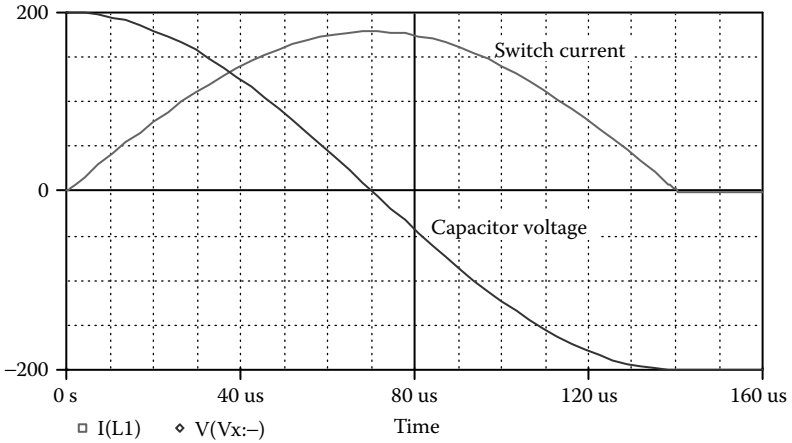
The voltage source  $VX = 0\text{ V}$  is inserted to monitor the controlling current. The listing of the circuit file is as follows:

### Example 5.6 Current-controlled switch

```

SOURCE ■■ * C1 of 40 μF with an initial voltage of 200 V:
C1 1 0 4 0UF IC=200
* Dummy voltage source of VX = 0:
VX 2 1 DC 0V
* Current-controlled switch with model name SMOD:
W1 2 3 VX SMOD
* Model parameters:
.MODEL SMOD ISWITCH (RON=1E+6 ROFF=0.001 ION=1MA IOFF=0)
L1 3 0 50UF

CIRCUIT ■■■ * Transient analysis with UIC (use initial condition)
option:
.TRAN 1US 160US UIC
* Plot the voltage at node 1 and the current through VX.
.PLOT TRAN V(1) I(VX) ; On the output file
.PROBE ; Graphics post-processor
.END
    
```



**FIGURE 5.29** Transient response for Example 5.6.

The results of the simulation that are obtained by using Probe are shown in Figure 5.29. Switch  $S_1$  acts as diode and allows only positive current flow. The initial voltage on the capacitor is the driving source.

### 5.7.3 TIME-DEPENDENT SWITCHES

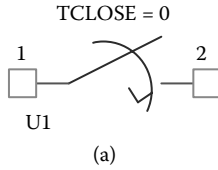
PSpice schematics support two types of time-dependent switches:

- Time-dependent close switch
- Time-dependent open switch

The closing or the opening time and the transition time of the switch are specified by the switch parameters as shown in Table 5.8.

**TABLE 5.8**  
**Model Parameters for Close/Open Switch**

Name	Meaning	Default
Tclose/Topen	Time at which switch begins to close/open	0
Ttran	Time required to switch states from off state to on state (must be realistic, not 0)	1 $\mu$ sec
Rclosed	Closed-state resistance	10 m $\Omega$
Ropen	Open-state resistance (Ropen/Rclosed < 1E+10)	1 M $\Omega$



Reference	Value	K13	RCLOSED	ROPEN	Source Part	TCLOSE	TTRAN
U1	Sw_tClose		0.01	1Meg	Sw_tClose.Normal	0	1u

(b)

**FIGURE 5.30** PSpice schematic for Sw\_tClose switch. (a) Schematic, (b) parameters of Sw\_tClose.

### 5.7.3.1 Time-Dependent Close Switch

This switch is normally open, and setting the closing time closes it. Its schematic is shown in Figure 5.30(a). The default parameters are shown in Figure 5.30(b).

#### EXAMPLE 5.7 PLOTTING THE TRANSIENT RESPONSE OF AN RC CIRCUIT WITH AN SW\_TCLOSE SWITCH

Figure 5.31(a) shows an RC circuit with a step input voltage, which is generated by a PWL source. The switch Sw\_tClose remains normally open. At  $t = 20\mu\text{sec}$ , the switch closes, and the capacitor is charged exponentially with a time constant of  $R_1C_1$  as shown in Figure 5.31(b).

### 5.7.3.2 Time-Dependent Open Switch

This switch is normally closed, and setting the opening time opens it. Its schematic is shown in Figure 5.32(a). The default parameters are shown in Figure 5.32(b).

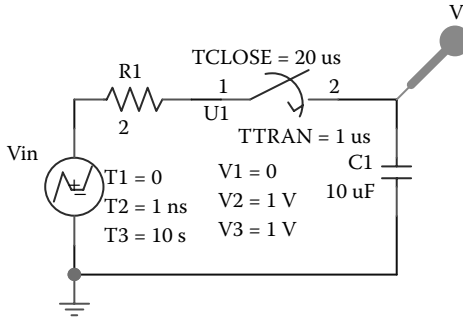
#### EXAMPLE 5.8 PLOTTING THE TRANSIENT RESPONSE OF AN RC CIRCUIT WITH AN SW\_TOPEN SWITCH

Figure 5.33(a) shows an RC circuit with a step input voltage, which is generated by a PWL source. The switch Sw\_tOpen remains normally close. At  $t = 20\mu\text{sec}$ , the switch opens and the capacitor is discharged exponentially with a time constant of  $R_1C_1$  as shown in Figure 5.33(b).

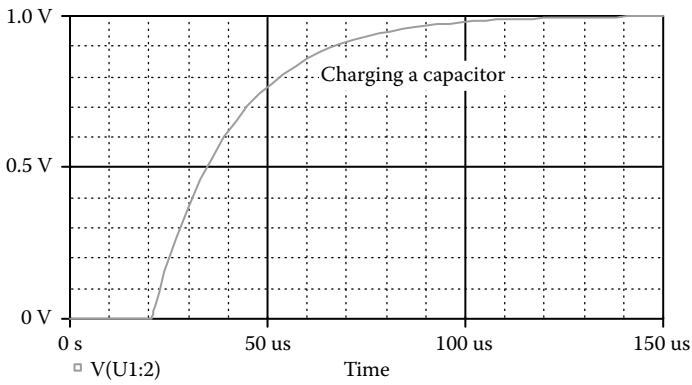
## SUMMARY

The symbols of the passive elements are:

- C Capacitor  
C<name> N+ N- CNAME CVALUE IC=V0

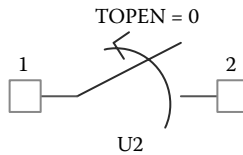


(a)



(b)

**FIGURE 5.31** PSpice schematic for charging an RC Circuit. (a) PSpice schematic, (b) output voltage at switch transition (on).

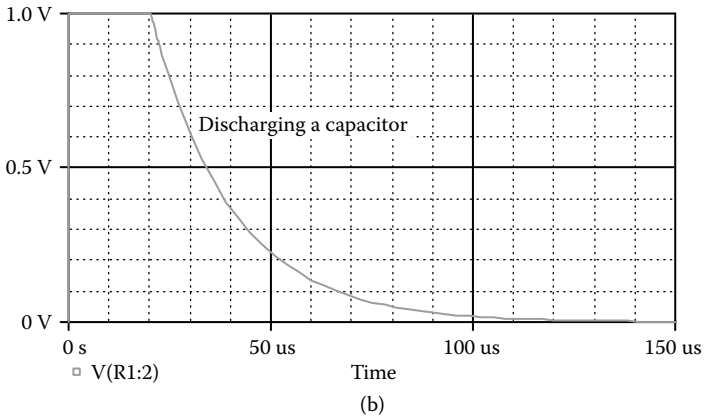
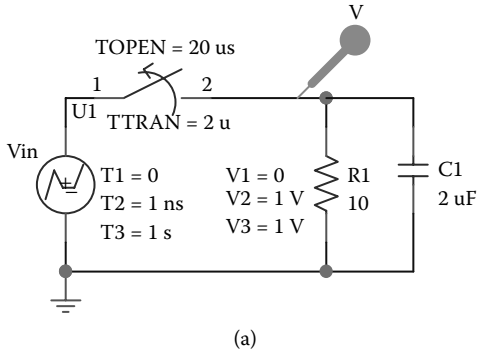


(a)

Reference	Value	K13	RCLOSED	ROPEN	Source Part	TOPEX	TTRAN
U2	Sw_tOpen		0.01	1Meg	Sw_tOpen.Normal	0	1u

(b)

**FIGURE 5.32** PSpice schematic for Sw\_tOpen switch. (a) Schematic, (b) parameters of Sw\_tOpen.



**FIGURE 5.33** PSpice schematic for discharging an RC Circuit. (a) PSpice schematic, (b) output voltage at switch transition (off).

- L Inductor  
L<name> N+ N- LNAME LVALUE IC=10
- K Linear mutual inductors (transformer)  
K<name> L<(first inductor) name>  
L<(second inductor)name> <value>]
- K Nonlinear inductor  
K<name> L<(inductor) name> <(coupling value)>  
+ <(model) name> [(size) value]
- R Resistor  
R<name> N+ N- RNAME RVALUE
- S Voltage-controlled switch  
S<name> N+ N- NC+ NC- SNAME

- T Lossless transmission lines  
 T<name> NA+ NA- NB+ NB- Z0=<value> [TD=<value>]  
 + [F=<value> NL=<value>]
- W Current-controlled switch  
 W<name> N+ N- VN WNAME

## Suggested Reading

1. D.C. Jiles and D.L. Atherton, Theory of ferromagnetic hysteresis, *Journal of Magnetism and Magnetic Material*, Vol. 61, No. 48, 1986, pp. 48-60.
2. M.H. Rashid, *Introduction to PSpice Using OrCAD for Circuits and Electronics*, 3rd ed., Englewood Cliffs, NJ: Prentice-Hall, 2003 chap. 4.
3. M.H. Rashid, *SPICE For Power Electronics and Electric Power*. Englewood Cliffs, NJ: Prentice-Hall, 1993.
4. *PSpice Manual*, Irvine, CA: MicroSim Corporation, 1992.
5. J.F. Lindsay and M.H. Rashid, *Electromechanics and Electrical Machinery*. Englewood Cliffs, NJ: Prentice-Hall, 1986.

## PROBLEMS

Write the PSpice statements for the following circuits. If applicable, the output should also be available for display and as hard copy by using Probe.

### 5.1

A resistor  $R_1$ , which is connected between nodes 3 and 4, has a nominal value of  $R = 10 \text{ k}\Omega$ . The operating temperature is  $55^\circ\text{C}$ , and it has the form

$$R_1 = R[1 + 0.2(T - T_0) + 0.002(T - T_0)^2]$$

### 5.2

A resistor  $R_1$ , which is connected between nodes 3 and 4, has a nominal value of  $R = 10 \text{ k}\Omega$ . The operating temperature is  $55^\circ\text{C}$ , and it has the form

$$R_1 = R \times 1.01^{4.5(T - T_0)}$$

### 5.3

A capacitor  $C_1$ , which is connected between nodes 5 and 6, has a value of  $10 \text{ pF}$  and an initial voltage of  $-20 \text{ V}$ .

## 5.4

A capacitor  $C_1$ , which is connected between nodes 5 and 6, has a nominal value of  $C = 10$  pF. The operating temperature is  $T = 55^\circ\text{C}$ . The capacitance, which is a function of its voltage and the operating temperature, is given by

$$C_1 = C (1 + 0.01V + 0.002V^2) \\ \times [1 + 0.03(T - T_0) + 0.05(T - T_0)^2]$$

## 5.5

An inductor  $L_1$ , which is connected between nodes 5 and 6, has a value of 0.5 mH and carries an initial current of 0.04 mA.

## 5.6

An inductor  $L_1$ , which is connected between nodes 3 and 4, has a nominal value of  $L = 1.5$  mH. The operating temperature is  $T = 55^\circ\text{C}$ . The inductance is a function of its current and the operating temperature, and it is given by

$$L_1 = L (1 + 0.01I + 0.002I^2) \\ \times [1 + 0.03(T - T_0) + 0.05(T - T_0)^2]$$

## 5.7

The two inductors, which are oppositely coupled as shown in [Figure 5.10\(b\)](#), are  $L_1 = 1.2$  mH and  $L_2 = 0.5$  mH. The coefficients of coupling are  $K_{12} = K_{21} = 0.999$ .

## 5.8

Plot the transient response of the circuit in [Figure P5.8](#) from 0 to 5 msec with a time increment of 25  $\mu\text{sec}$ . The output voltage is taken across the capacitor. Use Probe for graphical output.

## 5.9

Repeat Problem 5.8 for the circuit of [Figure P5.9](#).

## 5.10

Plot the frequency response of the circuit in [Figure P5.10](#) from 10 Hz to 100 kHz with a decade increment and 10 points per decade. The output voltage is taken across the capacitor. Print and plot the magnitude and phase angle of the output voltage. Assume a source voltage of 1 V peak.

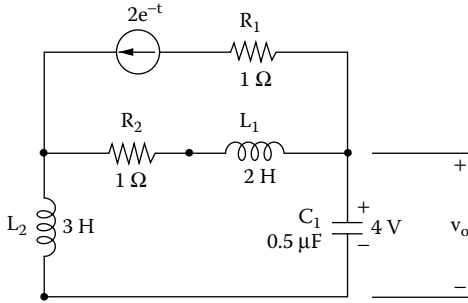


FIGURE P5.8 RLC circuit with an exponential current source.

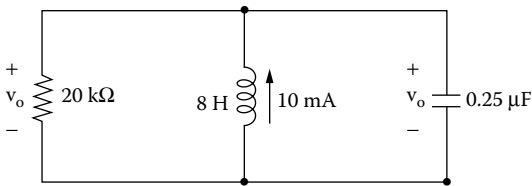


FIGURE P5.9 Parallel RLC circuit.

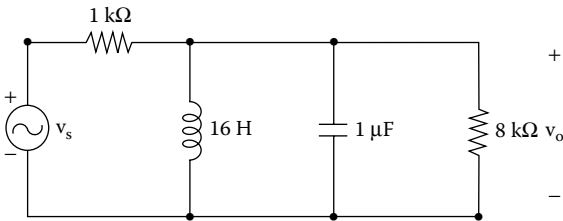


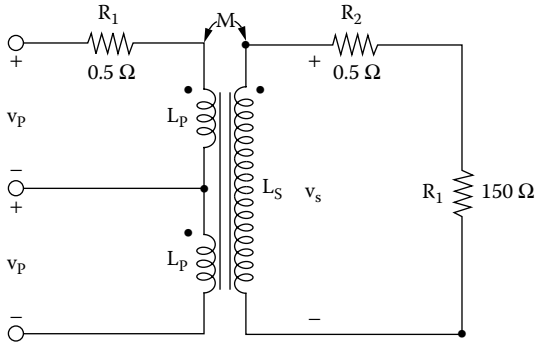
FIGURE P5.10 Series parallel circuit.

5.11

As shown in Figure P5.11, a single-phase transformer has a center-tapped primary, where  $L_p = 1.5$  mH,  $L_s = 1.3$  mH, and  $K_{ps} = K_{sp} = 0.999$ . The primary voltage is  $v_p = 170 \sin(377t)$ . Plot the instantaneous secondary voltage and load current from 0 to 35 msec with a 0.1-msec increment. The output should also be available for display and as hard copy by using Probe.

5.12

Repeat Problem 5.11 assuming the transformer to be nonlinear with  $L_p = 200$  turns and  $L_s = 100$  turns. The model parameters of the core are  $AREA = 2.0$ ,



**FIGURE P5.11** Center-tapped transformer.

PATH = 62.73, GAP = 0.1, MS = 1.6E + 6, ALPHA = 1E - 3, A = 1E + 3, C = 0.5, and K = 1500.

### 5.13

A three-phase transformer, which is shown in [Figure P5.13](#), has  $L_1 = L_2 = L_3 = 1.2$  mH and  $L_4 = L_5 = L_6 = 0.5$  mH. The coupling coefficients between the primary and secondary of each phase are  $K_{14} = K_{41} = K_{25} = K_{52} = K_{36} = K_{63} = 0.9999$ . There is no cross-coupling with other phases. The primary phase voltage is  $v_p = 170 \sin(377t)$ . Plot the instantaneous secondary phase voltage and load phase current from 0 to 35 msec with a 0.1-msec increment. Assume balanced three-phase input voltages.

### 5.14

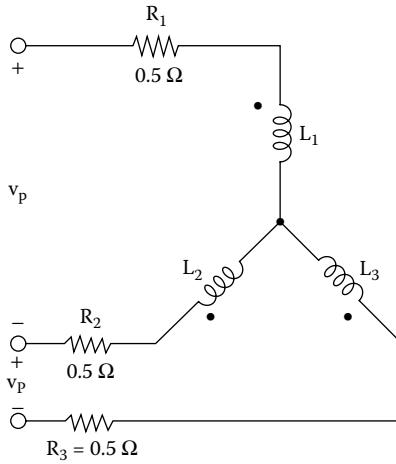
Repeat Problem 5.13 assuming the transformer to be nonlinear with  $L_1 = L_2 = L_3 = 200$  turns and  $L_4 = L_5 = L_6 = 100$  turns. The model parameters of the core are AREA = 2.0. PATH = 62.73, GAP = 0.1, MS = 1.6E + 6, ALPHA = 1E - 3, A = 1E + 3, C = 0.5, and K = 1500.

### 5.15

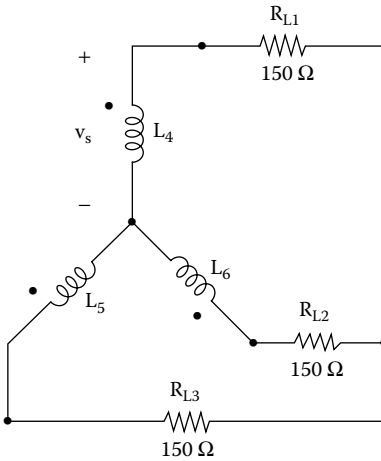
A switch that is connected between nodes 5 and 4 is controlled by a voltage source between nodes 3 and 0. The switch will conduct if the controlling voltage is 0.5 V. The on-state resistance is 0.5  $\Omega$ , and the off-state resistance is 2E + 6  $\Omega$ .

### 5.16

A switch that is connected between nodes 5 and 4 is controlled by a current. The voltage source  $V_1$  through which the controlling current flows is connected between nodes 2 and 0. The switch will conduct if the controlling current is 0.55 mA. The on-state resistance is 0.5  $\Omega$ , and the off-state resistance is 2E + 6  $\Omega$ .



(a) Primary



(b) Secondary

FIGURE P5.13 Three-phase transformer.

5.17

For the circuit in Figure P5.17, plot the transient response of the load and source currents for five cycles of the switching period with a time increment of 10  $\mu$ sec. The model parameters of the voltage-controlled switches are  $R_{ON} = 0.025$ ,  $R_{OFF} = 1E + 8$ ,  $V_{ON} = 0.05$ , and  $V_{OFF} = 0$ . The output should also be available for display and as hard copy by using Probe.

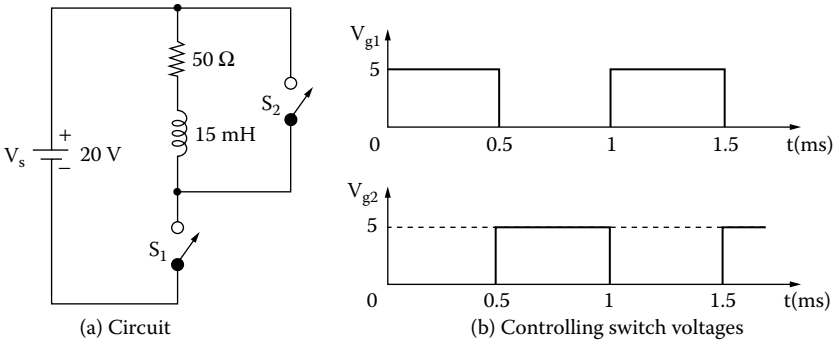


FIGURE P5.17 Switching circuit.

---

# 6 Dot Commands

The learning objectives of this chapter are:

- Defining and calling a “subcircuit”
- Defining a mathematical function and assigning a global node or parameter
- Setting a node at a specific voltage and including a library file
- Using the option parameters and setting their values to avoid conference problems
- Performing parametric and step variations on the analysis
- Assigning tolerances of components and model parameters
- Performing advanced analyses such as Fourier series of output voltages and currents, and noise, worst-case, and Monte Carlo analyses.

## 6.1 INTRODUCTION

PSpice has commands for performing various analyses, getting different types of output, and modeling elements. These commands begin with a dot and are known as *dot commands*. They can be selected from the PSpice Schematics menu as shown in [Figure 6.1](#) and can be used to specify:

- Models
- Types of output
- Operating temperature and end of circuit
- Options
- DC analysis
- AC analysis
- Noise analysis
- Transient analysis
- Fourier analysis
- Monte Carlo analysis

*Note:* If you are not sure about a command and its effect, run a circuit file with the command and check the results. If there is a syntax error, PSpice will display a message identifying the problem.

## 6.2 MODELS

PSpice allows one to (1) model an element based on its parameters, (2) model a small circuit that is repeated a number of times in the main circuit, (3) use a

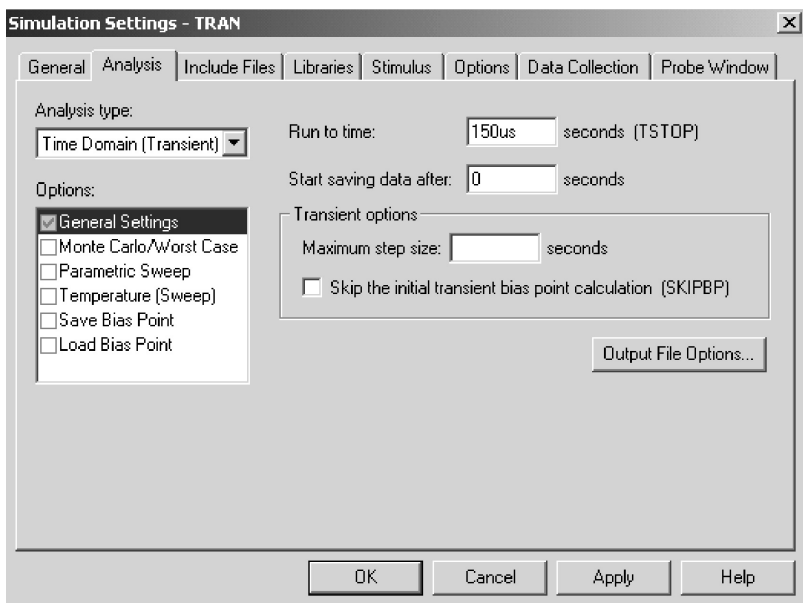


FIGURE 6.1 PSpice simulation settings menu.

model that is defined in another file, (4) use a user-defined function, (5) use parameters instead of number values, and (6) use parameter variations. The commands are as follows:

.MODEL	Model
.SUBCKT	Subcircuit
.ENDS	End of subcircuit
.FUNC	Function
.GLOBAL	Global
.LIB	Library file
.INC	Include file
.PARAM	Parameter
.STEP	Parametric analysis

### 6.2.1 .MODEL (MODEL)

The .MODEL command was discussed in Section 5.2.

### 6.2.2 .SUBCKT (SUBCIRCUIT)

A subcircuit permits one to define a block of circuitry and then to use that block in several places. The general form for subcircuit definition (or description) is

```
.SUBCKT SUBNAME [(two or more) nodes]
```

The symbol of a subcircuit call is X. The general form of a call statement is

```
X <name> [(two or more) nodes] SUBNAME
```

SUBNAME is the name of the subcircuit definition, and <(two or more) nodes> are the nodes of the subcircuit. X<name> causes the referenced subcircuit to be inserted into the circuit with given nodes replacing the argument nodes in the definition. The subcircuit name SUBNAME may be considered as equivalent to a subroutine name in FORTRAN programming, where X<name> is the call statement and <two or more> nodes are the variables or arguments of the subroutine.

Subcircuits may be nested. That is, subcircuit A may call other subcircuits. But the nesting cannot be circular, which means that if subcircuit A contains a call to subcircuit B, subcircuit B must not contain a call to subcircuit A. There must be the same number of nodes in the subcircuit calling statement as in its definition. The subcircuit definition should contain only element statements (statements without a dot) and may contain .MODEL statements.

### 6.2.3 .ENDS (END OF SUBCIRCUIT)

A subcircuit must end with an .ENDS statement. The end of a subcircuit definition has the general form

```
.ENDS SUBNAME
```

SUBNAME is the name of the subcircuit, and it indicates which subcircuit description is to be terminated. If the .ENDS statement is missing, all subcircuit descriptions are terminated.

Subcircuit statements end with

```
.ENDS OPAMP
```

```
.ENDS
```

*Note:* The name of the subcircuit can be omitted. However, it is advisable to identify the name of the subcircuit to be terminated, especially if there is more than one subcircuit.

#### EXAMPLE 6.1 DESCRIBING A SUBCIRCUIT

Write the subcircuit call and subcircuit description for the op-amp circuit of [Figure 6.2](#).

#### SOLUTION

The listing of statements for the subcircuit call and description are as follows:

In PSpice Schematics, the net list for a subcircuit can be created by using the command Create Netlist from the PSpice menu.

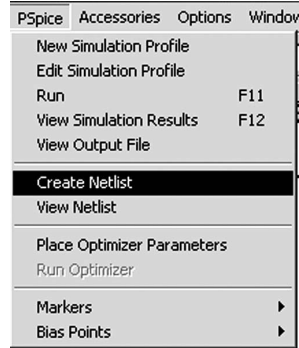
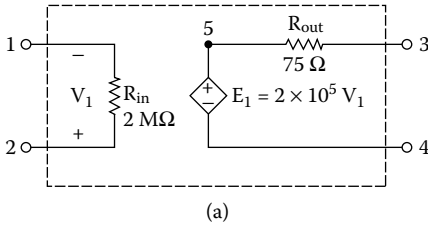


FIGURE 6.2 Op-amp subcircuit. (a) Circuit, (b) Create Netlist from PSpice menu.

\* The call statement X1 to be connected to input nodes 1 and 4 and the output nodes 7 and 9: The subcircuit name is OPAMP. Nodes 1, 4, 7, and 9 are referred to the main circuit file and do not interact with the nodes of the subcircuit.

```
X1      1      4      7      9      OPAMP
*      vi-    vi+    vo+    vo-    model name
*      The subcircuit definition: Nodes 1, 2, 3, and 4 are referred
to the subcircuit and do not interact with the nodes of the main
circuit.
.SUBCKT      OPAMP      1      2      3      4
*      model name      vi-    vi+    vo+    vo-
RIN      1      2      2MEG
ROUT     5      3      75
E1       5      4      2      1      0.2MEG ; Voltage-controlled
                                         voltage source
.ENDS      OPAMP      ; End of subcircuit
                                         definition OPAMP
```

*Note:* There is no interaction between the nodes in the main circuit and the subcircuit. Node numbers in the subcircuit are independent of those in the main circuit. However, the subcircuit should not have node 0, because node 0, which is considered global by PSpice, is the ground.

### 6.2.4 .FUNC (FUNCTION)

A function statement can be used to define functions that may be used in expressions discussed in Subsection 4.5.1. The functions are defined by users and are, therefore, flexible. They are also useful for overcoming the restriction that expressions be limited to a single line and for the case where there are several similar subexpressions in a single circuit file. The general form of a function statement is

```
.FUNC FNAME (arg) <function>
```

`FNAME (arg)` is the name of the function with argument `arg`. `FNAME` must not be the same as the names of the built-in functions described in Subsection 4.5.1, such as “sin.” Up to ten arguments may be used in a definition. The number of arguments in the use of a function must agree with the number in the definition. A function may be defined with no arguments, but the parentheses are still required. `<function>` may refer to other functions defined previously. The `.FUNC` statement must precede the first use of `FNAME`. The users can create a file of frequently used `.FUNC` definitions and access them with an `.INC` statement (Subsection 6.2.7) near the beginning of the circuit file.

Some function statements are

```
.FUNC E(x)          exp (x)
.FUNC Sinh(x)      (E(x)+E(-x))/2
.FUNC MIN(C,D)    (C+D-ABS(C-D))/2
.FUNC MAX(C,D)    (C+D+ABS(C-D))/2
.FUNC IND(I(Vsense)) (A0+A1*I(V(Sense))+
A2*I(V(Sense))+I(V(Sense)))
```

Note the following:

1. The definition of the `<function>` must be restricted to one line.
2. In-line comments must not be used after the `<function>` definition.
3. The last statement illustrates a current-dependent nonlinear inductor.

### 6.2.5 .GLOBAL (GLOBAL)

PSpice has the capability of defining global nodes. These nodes are accessible by all subcircuits without being passed in as arguments. Global nodes may be handy for such applications as power supplies, power converters, and clock lines.

For PSpice Schematics, the symbol of a global node is shown in Figure 6.3. The general statement is

```
.GLOBAL N
```

where `N` is the node number. For example,

```
.GLOBAL 4
```

makes node 4 global to the circuit file and subcircuit(s).



**FIGURE 6.3** Global node.

## 6.2.6 .LIB (LIBRARY FILE)

A library file may be referenced into the circuit file by using the statement

```
.LIB FNAME
```

FNAME is the name of the library file to be called. A library file may contain comments, .MODEL statements, subcircuit definition, .LIB statements, and .END statements. No other statements are permitted. If FNAME is omitted, PSpice looks for the default file, EVAL.LIB, that comes with PSpice programs. The library file FNAME may call for another library file. When a .LIB command calls for a file, it does not bring the entire text of the library file into the circuit file. It simply reads in those models or subcircuits that are called by the main circuit file. As a result, only those models or subcircuit descriptions that are needed by the main circuit file take up the main memory (RAM) space.

Some library file statements are

```
.LIB
```

```
.LIB NOM.LIB (library file NOM.LIB is on the
              default drive)
```

```
.LIB B:\LIB\NOM.LIB (library file NOM.LIB is on
                    directory file LIB in drive B)
```

```
.LIB C:\LIB\NOM.LIB (library file NOM.LIB is in
                    directory file LIB on drive C)
```

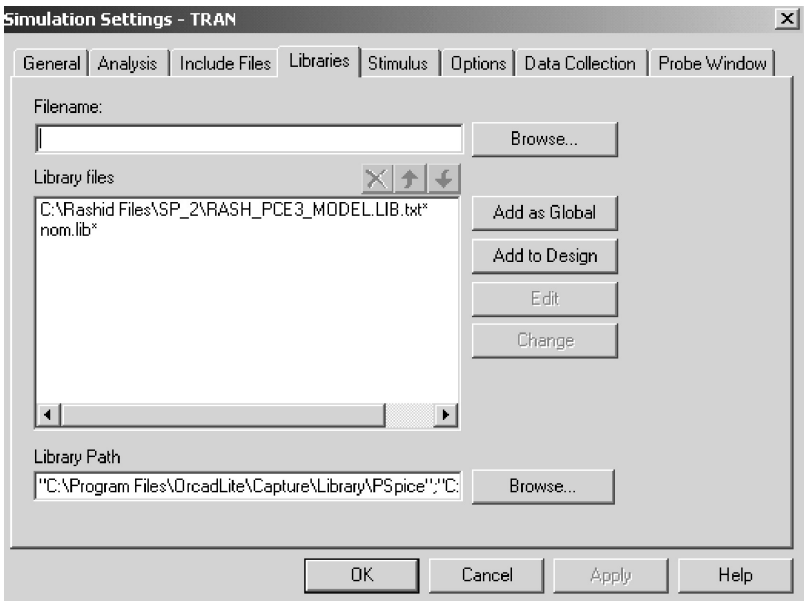


FIGURE 6.4 Libraries menu.

In PSpice schematics, the library files are selected from the command Library from the PSpice Simulation Settings menu as shown in Figure 6.4.

### 6.2.7 .INC (INCLUDE FILE)

The contents of another file may be included in the circuit file using the statement

```
.INC NFILE
```

NFILE is the name of the file to be included and may be any character string that is a legal file name for computer systems. It may include a volume, directory, and version number.

Included files may contain any statements except a title line. However, a comment line may be used instead of a title line. If a .END statement is present, it only marks the end of an included file. An .INC statement may be used only up to four levels of “including.” The include statement simply brings everything of the included file into the circuit file and takes up space in main memory (RAM).

Some include file statements are

```
.INC OPAMP.CIR
```

```
.INC a:INVERTER.CIR
```

```
.INC c:\LIB\NOR.CIR
```

In PSpice schematics, Include Files is selected from the command Include Files of the PSpice Simulation Settings menu as shown in Figure 6.5.

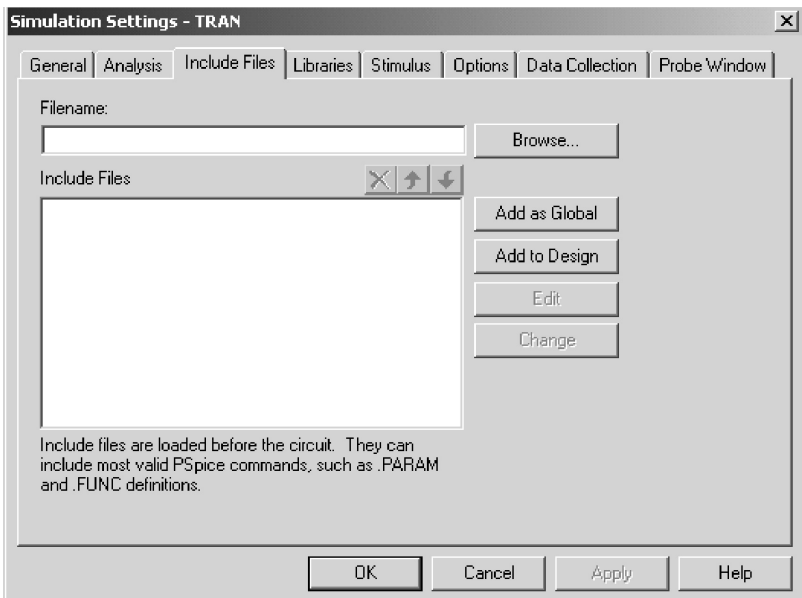


FIGURE 6.5 Include files.

Parameters:

LVAL = 1.5 mH

RVAL = 1 k

CVAL = 1 uF

(a)

Reference	Value	RVAL	LVAL	CVAL	Source Part
1	PARAM	1k	1.5mH	1uF	PARAM.Normal

(b)

**FIGURE 6.6** Parametric definitions. (a) Symbol, (b) parameters.**6.2.8 .PARAM (PARAMETER)**

In many applications it is convenient to use a parameter instead of a numerical value, such that the parameter can be combined into arithmetic expressions. The parameter definition is one of the forms

```
.PARAM <PNAME = <value> or { <expression> } >*
```

The keyword `.PARAM` is followed by a list of names with values or expressions. `<value>` must be a constant and does not need “{” and “}”. `<expression>` must contain only parameters defined previously. `PNAME` is the parameter name, and it cannot be a predefined parameter such as `TIME` (time), `TEMP` (temperature), `VT` (thermal voltage), or `GMIN` (shunt conductance for semiconductor *p-n* junctions).

Figure 6.6(a) shows the symbol, and the parameters of `PARAM` are shown in Figure 6.6(b).

Some `PARAM` statements are

```
.PARAM VSUPPLY = 12V
```

```
.PARAM VCC = 15 V, VEE = -15V
```

```
.PARAM BANDWIDTH = {50kHz/5}
```

```
.PARAM PI = 3.14159, TWO-PI = {2*3.14159}
```

Once a parameter is defined, it can be used in place of numerical value; for example,

```
VCC 1 0 {SUPPLY}
```

```
VEE 0 5 {SUPPLY}
```

will change the value of `SUPPLY` in both statements. For example,

```
.FUNC IND(I(Vsense)) (A0+A1*I(V(Sense))+
A2*I(V(Sense))+I(V(Sense)))
```

```
.PARAM INDUCTOR = IND (I (Vsense))
```

```
L1 1 3 {INDUCTOR}
```

will change the value of `INDUCTOR`.

Parameters defined in `.PARAM` statement are global; they can be used anywhere in the circuit, including inside subcircuits. The parameters can be made local to subcircuits by having parameters as arguments to subcircuits. For example,

```
.SUBCKT FILTER 1 2 PARAMS: CENTER=100kHz,
WIDTH=10kHz
```

is a subcircuit definition for a band-pass filter with nodes 1 and 2 and with parameters **CENTER** (center frequency) and **WIDTH** (bandwidth). **PARAMS** separate the nodes list from the parameter list. When calling this subcircuit **FILTER**, the parameters can be given new values, for example,

```
X1 4 6 FILTER PARAMS: CENTER=200kHz
```

will override the default value of 100 kHz with a **CENTER** value of 200 kHz.

A defined parameter can be used in the following cases:

1. All model parameters
2. Device parameters, such as **AREA**, **L**, **NRD**, **Z0**, and **IC** values on capacitors and inductors, and **TC1** and **TC2** for resistors
3. All parameters of independent voltage and current sources (**V** and **I** devices)
4. Values on **.NODESET** statement (Subsection 6.6.2) and **.IC** statement (Subsection 6.9.1)

A defined parameter cannot be used for:

1. Transmission line parameters **NL** and **F**
2. In-line temperature coefficients for resistors
3. **E**, **F**, **G**, and **H** device polynomial coefficient values
4. Replacing node numbers
5. Values on analysis statements (**.TRAN**, **.AC**, **.DC**, etc.)

### 6.2.9 .STEP (PARAMETRIC ANALYSIS)

In PSpice Schematics, this command is selected from the Parametric Sweep option from the PSpice Simulation Settings menu as shown in [Figure 6.7](#).

The effects of parameter variations can be evaluated by the **.STEP** command, whose general statement takes the general forms

```
.STEP LIN SWNAME SSTART SEND SINC
.STEP OCT SWNAME SSTART SEND NP
.STEP DEC SWNAME SSTART SEND NP
.STEP SWNAME LIST <value>*
```

**SWNAME** is the sweep variable name. **SSTART**, **SEND**, and **SINC** are the start value, the end value, and the increment value of the sweep variables, respectively. **NP** is the number of steps. **LIN**, **OCT**, or **DEC** specifies the type of sweep as follows:

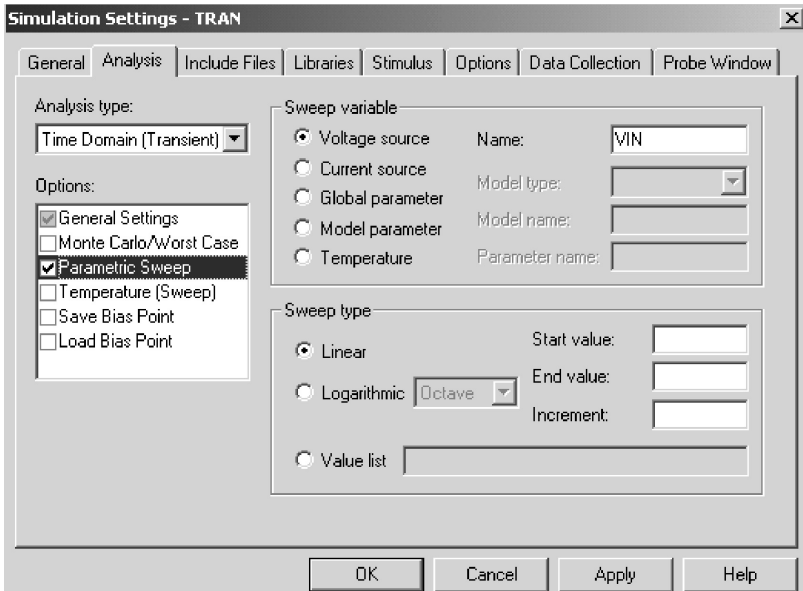


FIGURE 6.7 Parametric Sweep menu.

- LIN** *Linear sweep:* SWNAME is swept linearly from SSTART to SEND. SINC is the step size.
- OCT** *Sweep by octave:* SWNAME is swept logarithmically by octave, and NP becomes the number of steps per octave. The next variable is generated by multiplying the present value by a constant larger than unity. OCT is used if the variable range is wide.
- DEC** *Sweep by decade:* SWNAME is swept logarithmically by decade, and NP becomes the number of steps per decade. The next variable is generated by multiplying the present value by a constant larger than unity. DEC is used if the variable range is widest.
- LIST** *List of values:* There are no start and end values. The values of the sweep variables are listed after the keyword LIST.

The SWNAME can be one of the following types:

*Source:* name of an independent voltage or current source. During the sweep, the source's voltage or current is set to the sweep value.

*Model parameter:* model name type and model name followed by a model parameter name in parentheses. The parameter in the model is set to the sweep value. The model parameters L and W for MOS device and any temperature parameters such as TC1 and TC2 for the resistor cannot be swept.

*Temperature:* keyword TEMP followed by the keyword LIST. The temperature is set to the sweep value. For each value of sweep, the model parameters of all circuit components are updated to that temperature.

*Global parameter:* keyword PARAM followed by parameter name. The parameter is set to sweep. During the sweep, the global parameter's value is set to the sweep value and all expressions are evaluated.

Some STEP statements are

```
.STEP VCE 0V 10V -5V
```

sweeps the voltage VCE linearly.

```
.STEP LIN IS -10mA 5mA 0.1mA
```

sweeps the current IS linearly.

```
.STEP RES RMOD(R) 0.9 1.1 0.001
```

sweeps linearly the model parameter R of the resistor model RMOD.

```
.STEP DEC NPN QM(IS) 1E-18 1E-14 10
```

sweeps with a decade increment the parameter IS of the NPN transistor.

```
.STEP TEMP LIST 0 50 80 100 150
```

sweeps the temperature TEMP as listed.

```
.STEP PARAM Centerfreq 8.5 kHz 10.5kHz 50Hz
```

sweeps linearly the parameter PARAM Centerfreq.

Note the following:

1. The sweep start value SSTART may be greater than or less than the sweep end value SEND.
2. The sweep increment SINC must be greater than zero.
3. The number of points NP must be greater than zero.
4. If the .STEP command is included in a circuit file, all analyses specified (.DC, .AC, .TRAN, etc.) are performed for each step.

## 6.3 TYPES OF OUTPUT

The commands that are available to obtain output from the results of simulations are

.PRINT	Print
.PLOT	Plot
.PROBE	Probe
Probe output	
.WIDTH	Width

### 6.3.1 .PRINT (PRINT)

The results of DC, AC, transient (.TRAN), and noise (.NOISE) analyses can be obtained in the form of tables.

In PSpice schematics, output markers rather than PRINT commands are normally used for plotting the transient and frequency response (AC analysis). PRINT commands can be used for printing data points on electronic files.

The print statement takes one of the forms

```
.PRINT DC      <output variables>
.PRINT AC      <output variables>
.PRINT TRAN    <output variables>
.PRINT NOISE   <output variables>
```

The maximum number of output variables is eight in any .PRINT statement. However, more than one .PRINT statement can be used to print all the output variables desired. The values of the output variables are printed as a table, with each column corresponding to one output variable. The number of digits for output values can be changed with the NUMDGT option on the .OPTIONS statement as described in Section 6.4. The results of the .PRINT statement are stored in the output file.

Some print statements are

```
.PRINT DC V(2), V(3,5), V(R1), VCE(Q2), I(VIN),
I(R1), IC(Q2)
.PRINT AC VM(2), VP(2), VM(3,5), V(R1), VG(5),
VDB(5), IR(5), II(5)
.PRINT NOISE INOISE ONOISE DB(INOISE) DB(ONOISE)
.PRINT TRAN V(5) V(4,7) (0,10V) IB(Q1) (0,50MA)
IC(Q1) (-50MA, 50MA)
```

*Note:* Having two .PRINT statements for the same variable will not produce two tables. PSpice will ignore the first statement and produce output for the second statement.

### 6.3.2 .PLOT (PLOT)

In PSpice Schematics, the PLOT commands are rarely used because of the availability of graphical output devices such as Probe (Subsection 6.3.3)

The results of DC, AC, transient (.TRAN), and noise (.NOISE) analyses can be obtained in the form of line printer plots. The plots are drawn by using characters and the results can be obtained in any type of printer. The plot statement takes one of the forms

```
.PLOT DC <output variables>
      + (<(lower limit) value>, <(upper limit) value>)
.PLOT AC <output variables>
      + [<(lower limit) value>, <(upper limit) value>]
.PLOT TRAN <output variables>
      + [<(lower limit) value>, <(upper limit) value>]
.PLOT NOISE <output variables>
      + [<(lower limit) value>, <(upper limit) value>]
```

The maximum number of output variables is eight in any .PLOT statement. More than one .PLOT statement can be used to plot all the output variables desired.

The range and increment of the x axis is fixed by the type of analysis command (e.g., .DC, .AC, .TRAN, or .NOISE). The range of the y axis is set by adding (<(lower limit) value>, <(upper limit) value>) at the end of a .PLOT statement. The y-axis range, (<(lower limit) value> and <(upper limit) value>), can be placed in the middle of a set of output variables. The output variables will follow the range specified, which comes immediately to the left.

If the y-axis range is omitted, PSpice assigns a default range determined by the range of the output variable. If the ranges of output variables vary widely, PSpice assigns the ranges corresponding to the different output variables.

Some plot statements are

```
.PLOT DC V(2), V(3,5), V(R1), VCE(Q2), I(VIN),
I(R1), IC(Q2)
.PLOT AC VM(2), VP(2), VM(3,5), V(R1), VG(5),
VDB(5), IR(5), II(5)
.PLOT NOISE INOISE ONOISE DB(INOISE) DB(ONOISE)
.PLOT TRAN V(5) V(4,7) (0,10V) IB(Q1) (0, 50MA)
IC(Q1) (-50MA, 50MA)
```

*Note:* In the first three statements, the y axis is by default. In the last statement, the range for voltages V(5) and V(4,7) is 0 to 10 V, that for current IB(Q1) is 0 to 50 mA, and that for the current IC(Q1) is -50 to 50 mA.

### 6.3.3 .PROBE (PROBE)

Probe is a graphics postprocessor, and it is available as an option in the professional version of PSpice. However, Probe is included in the student's version of PSpice. The results of the DC, AC, and transient (.TRAN) analysis cannot be used directly by Probe. First, the results have to be processed by the .PROBE

command, which writes the processed data on a file, PROBE.DAT, for use by Probe. The command takes one of the forms

```
.PROBE
.PROBE (one or more output variables)
```

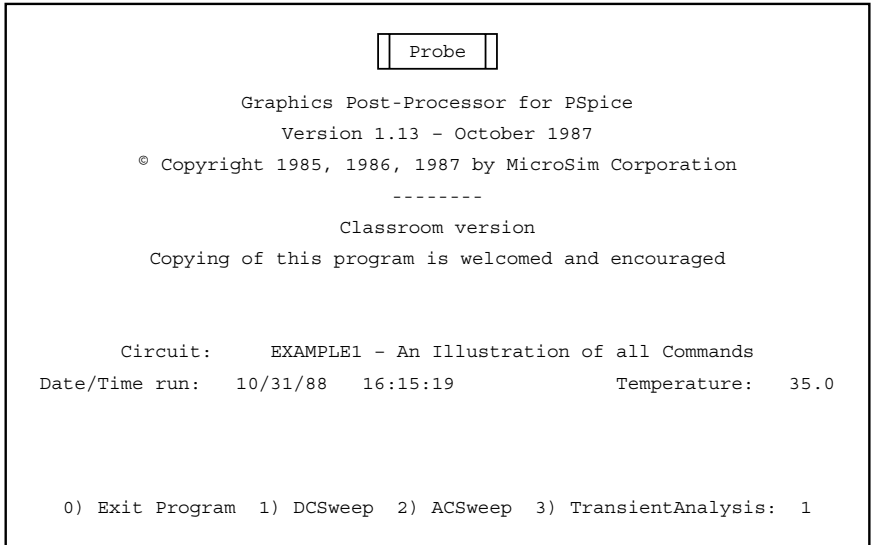
In the first form, in which no output variable is specified, the .PROBE command writes all the node voltages and all the element currents to the PROBE.DAT file. The element currents are written in the forms that are permitted as output variables and are discussed in Subsection 3.3.2. In the second form, in which the output variables are specified, PSpice writes only the specified output variables to the PROBE.DAT file. This form is suitable for users without a fixed disk and to limit the size of the PROBE.DAT file.

### Probe Statements

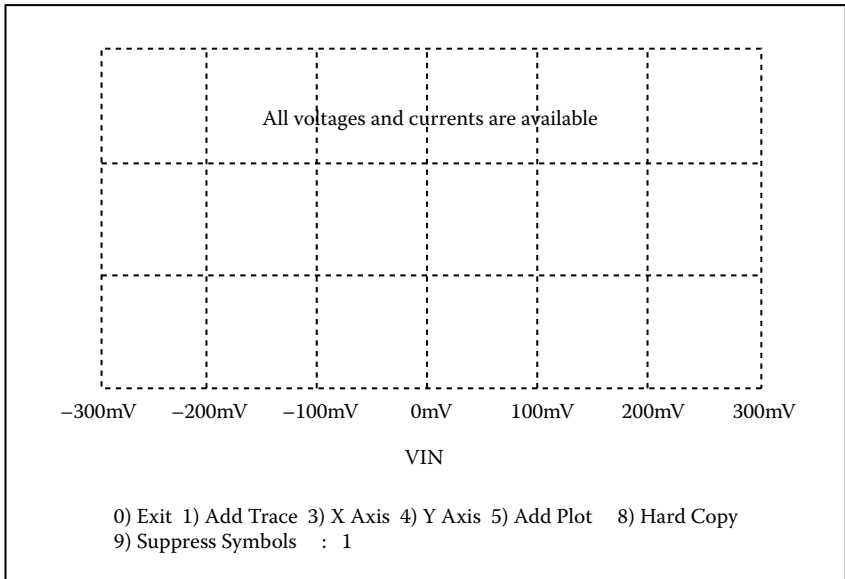
```
.PROBE
.PROBE V(5), V(4,3), V(C1), VM(2), I(R2), IB(Q1),
VBE(Q1)
```

### 6.3.4 PROBE OUTPUT

It is very easy to use Probe. Once the results of the simulations are processed by the .PROBE command, the results are available for graphics output. Probe comes with a first-level menu, as shown in Figure 6.8, from which the type of analysis



**FIGURE 6.8** Select analysis display for Probe.



**FIGURE 6.9** Select plot/graphics output.

can be chosen. After the first choice, the second level is the choice for the plots and coordinates of output variables as shown in Figure 6.9. After the choices, the output is displayed as shown in Figure 6.10.

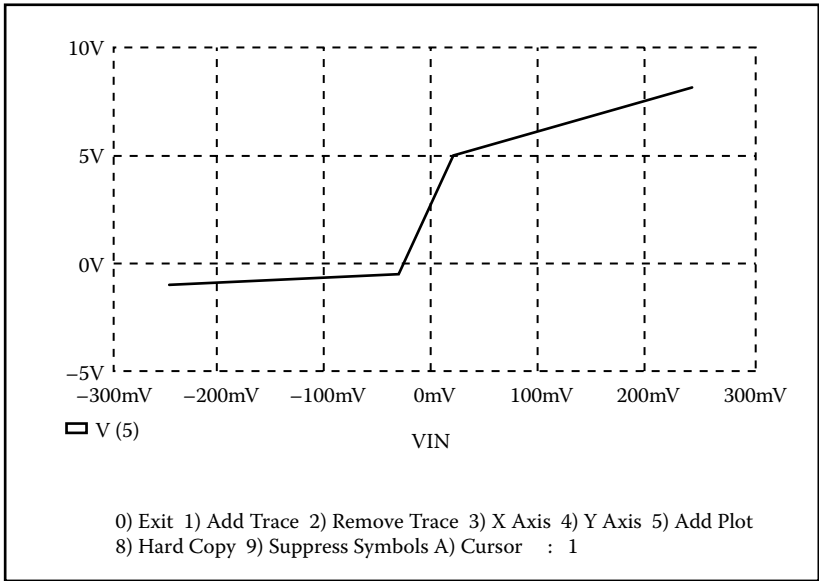
With one exception, Probe does not distinguish between uppercase and lowercase variable names, i.e., “V(4)” and “v(4)” are equivalent. The exception is the “m” scale suffix for numbers: “m” means “milli” ( $1E - 3$ ), whereas “M” means “mega” ( $1E + 6$ ). The suffixes “MEG” and “MIL” are not available. The units that are recognized by Probe are:

- V Volts
- A Amperes
- W Watts
- d Degrees (of phase)
- s Seconds
- H Hertz

Probe also recognizes that  $W = V \times A$ ,  $V = W/A$ , and  $A = W/V$ . Therefore, the addition of a trace, such as

VCE(Q1) \* IC(Q1)

gives the power dissipation of transistor  $Q_1$  and will be labeled with a “W.” Arithmetic expressions of output variables are also allowed and the available



**FIGURE 6.10** Output display.

operators are “+”, “-”, “\*”, and “/”, along with parentheses. The available functions are as follows:

Function	Meaning
ABS(x)	$ x $ (absolute value)
B(Kxy)	Flux density of coupled inductor $K_{xy}$
H(Kxy)	Magnetization of coupled inductor $K_{xy}$
SGN(x)	+ 1 (if $x > 0$ ), 0 (if $x = 0$ ), -1 (if $x < 0$ )
EXP(x)	$e^x$
DB(x)	$20 \log( x )$ (log of base 10)
LOG(x)	$\ln(x)$ (log of base $e$ )
LOG10(x)	$\log(x)$ (log of base 10)
PWR(x, y)	$ x ^y$
SQRT(x)	$x^{1/2}$
SIN(x)	$\sin(x)$ ( $x$ in radians)
COS(x)	$\cos(x)$ ( $x$ in radians)
TAN(x)	$\tan(x)$ ( $x$ in radians)
ARCTAN(x)	$\tan^{-1}(x)$ (result in radians)
d(y)	Derivative of $y$ with respect to the $x$ -axis variable
s(y)	Integral of $y$ over the $x$ -axis variable
AVG(x)	Running average of $x$
RMS(x)	Running rms average of $x$

For derivatives and integrals of simple variables (not expressions), the shorthand notations that are available are

$dV(4)$  is equivalent to  $d(V(4))$   
 $sIC(Q3)$  is equivalent to  $s(IC(Q3))$

The plot of  $dIC(Q2)/dIB(Q2)$  will give the small-signal beta value of  $Q_2$ .

Two or more traces can be added with only one Add Trace command, in which all the expressions are separated by “ ” or “;”; for instance:

```
V(2) V(4), IC(M1), RMS(I(VIN))
```

will add four traces. This gives the same result as using Add Trace four times with only one trace at a time, but is faster because the plot is not redrawn between the addition of each trace.

The PROBE.DAT file can contain more than one of any kind (e.g., two transient analyses with three temperatures). If PSpice is run for a transient analysis at three temperatures, the expression

```
V(1)
```

will result in Probe drawing three curves instead of the usual one curve. Entering the expression

```
V(1) @ n
```

will result in Probe drawing the curve of  $V(1)$  for the  $n$ th transient analysis. Entering the expression

```
V(1)@1-V(1)@2
```

will display the difference between the waveforms of the first and second temperatures, whereas the expression

```
V(1)-V(2)@2
```

will display three curves, one for each  $V(1)$ .

Note the following:

1. The .PROBE command requires a math coprocessor for the professional version of PSpice, but not for the student version.
2. Probe is not available on SPICE. However, the newest version of SPICE (SPICE3) has a postprocessor similar to Probe called Nutmeg.
3. It is required to specify the type of display and the type of hard-copy devices on the PROBE.DEV file as follows:
  - Display = <display name>
  - Hard copy = <port name>, <device name>
  - The details of names for display, port, and device (printer) can be found in the README.DOC file that comes with the PSpice programs or in the PSpice manual.
4. The display and hard-copy devices can be set from the display or printer setup menu.

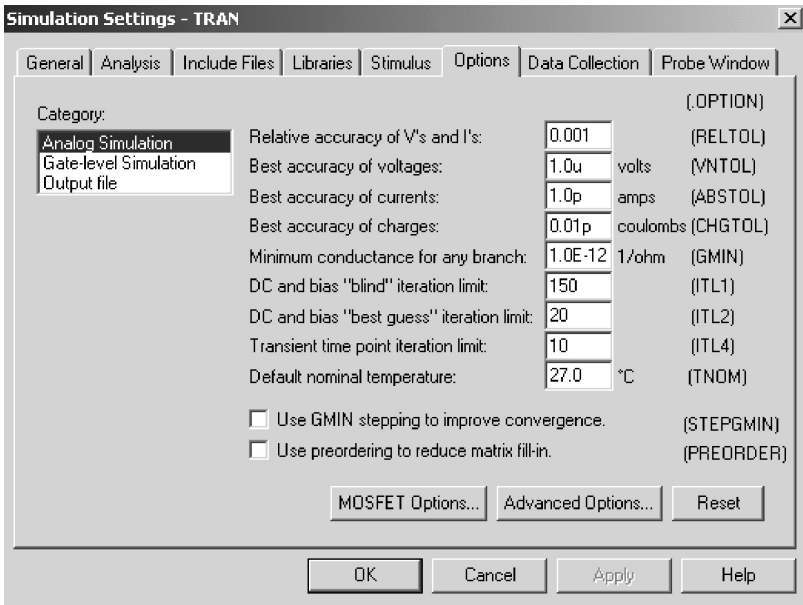


FIGURE 6.11 Options menu in the Simulation Settings

### 6.3.5 .WIDTH (WIDTH)

The width of the output in columns can be set by the `.WIDTH` statement, which has the general form

```
.WIDTH OUT = <value>
```

`<value>` is in columns and must be either 80 or 132. The default value is 80.

In PSpice Schematics, the width can be set from the Output file category of the Options submenu in the Simulation Settings menu as shown in Figure 6.11.

## 6.4 OPERATING TEMPERATURE AND END OF CIRCUIT

The temperature command is discussed in Section 5.3. The last statement for the end of a circuit is

```
.END
```

All data and commands must come before the `.END` command. The `.END` command instructs PSpice to perform all the circuit analysis specified. After processing the results of the analysis specified, PSpice resets itself to perform further computations, if required.

*Note:* An input file may have more than one circuit, where each circuit has its `.END` command. PSpice will perform all the analysis specified and processes

the results of each circuit one by one. PSpice resets everything at the beginning of each circuit. Instead of running PSpice separately for each circuit, this is a convenient way to perform the analysis of many circuits with one run statement.

## 6.5 OPTIONS

PSpice allows various options to control and to limit parameters for the various analyses. Figure 6.11 shows the option menu in the simulation settings.

The general form is

```
.OPTIONS [(options) name] [(options) name)=(value)]
```

The options can be listed in any order. There are two types of options, those without values and those with values. The options without values are used as flags of various kinds and only the option name is mentioned. Table 6.1 shows the options without values. The options with values are used to specify certain optional parameters. The option names and their values are specified. Table 6.2 shows the options with values. The commonly used options are NOPAGE, NOECHO, NOMOD, TNOM, CPTIME, NUMDGT, GMIN, and LIMPTS.

Options statements are

```
.OPTIONS NOPAGE NOECHO NOMOD DEFL=20U DEFW=15U
DEFAD=50P DEFAS=50P
```

```
.OPTIONS ACCT LIST RELTOL=.005
```

If the option ACCT is specified in the .OPTIONS statement, PSpice will print a *job statistics summary* displaying various statistics about the run at the end. This option is not required for most circuit simulations. The format of the summary (with an explanation of the terms appearing in it) is as follows:

Item	Meaning
NUNODS	Number of distinct circuit nodes before subcircuit expansion.
NCNODS	Number of distinct circuit nodes after subcircuit expansion. If there are no subcircuits, NCNODS = NUNODS.
NUMNOD	Total number of distinct nodes in circuit. This is NCNODS plus the internal nodes generated by parasitic resistances. If no device has parasitic resistances, NUMNOD = NCNODS.
NUMEL	Total number of devices (elements) in circuit after subcircuit expansion. This includes all statements that do not begin with “.” or “X.”
DIODES	Number of diodes after subcircuit expansion.
BJTS	Number of bipolar transistors after subcircuit expansion.
JFETS	Number of junction FETs after subcircuit expansion.
MFETS	Number of MOSFETs after subcircuit expansion.
GASFETS	Number of GaAs MESFETs after subcircuit expansion.
NUMTEM	Number of different temperatures.
ICVFLG	Number of steps of DC sweep.
JTRFLG	Number of print steps of transient analysis.

JACFLG	Number of steps of AC analysis.
INOISE	1 or 0: noise analysis was/was not done.
NOGO	1 or 0: run did/did not have an error.
NSTOP	The circuit matrix is conceptually (not physically) of dimension $NSTOP \times NSTOP$ .
NTTAR	Actual number of entries in circuit matrix at beginning of run.
NTTBR	Actual number of entries in circuit matrix at end of run.
NTTOV	Number of terms in circuit matrix that come from more than one device.
IFILL	Difference between NTTAR and NTTBR.
IOPS	Number of floating-point operations needed to do one solution of circuit matrix.
PERSPA	Percent sparsity of circuit matrix.
NUMTTP	Number of internal time steps in transient analysis.
NUMRTP	Number of times in transient analysis that a time step was too large and had to be cut back.
NUMNIT	Total number of iterations for transient analysis.
MEMUSE/ MAXMEM	Amount of circuit memory used/available in bytes. There are two memory pools. Exceeding either one will abort the run.
COPYKNT	Number of bytes that were copied in the course of doing memory management for this run.
READIN	Time spent reading and error checking the input file.
SETUP	Time spent setting up the circuit matrix pointer structure.
DCSWEEP	Time spent and iteration count for calculating DC sweep.
BIASPNT	Time spent and iteration count for calculating bias point and bias point for transient analysis.
MATSOL	Time spent solving circuit matrix (this time is also included in the time for each analysis). The iteration count is the number of times the rows or columns were swapped in the course of solving it.
ACAN	Time spent and iteration count for AC analysis.
TRANAN	Time spent and iteration count for transient analysis.
OUTPUT	Time spent preparing .PRINT tables and .PLOT plots.
LOAD	Time spent evaluating device equations (this time is also included in the time for each analysis).
OVERHEAD	Other time spent during run.
TOTAL JOB TIME	Total run time, excluding the time to load the program files PSPICE1.EXE and PSPICE2.EXE into memory.

---

## 6.6 DC ANALYSIS

In DC analysis, all the independent and dependent sources are of DC type. The inductors and capacitors in a circuit are considered as short circuits and open circuits, respectively. This is due to the fact that at zero frequency, the impedance represented by an inductor is zero and that by a capacitor is infinite. The commands that are available for DC analyses are

```
.OP           Dc operating point
.NODESET     Node set
.SENS        Small-signal sensitivity
```

**TABLE 6.1**  
**Options without Values**

Option	Effects
NOPAGE	Suppresses paging and printing of a banner for each major section of output
NOECHO	Suppresses listing of the input file
NODE	Causes output of net list (node table)
MONOD	Suppresses listing of model parameters
LIST	Causes summary of all circuit elements (devices) to be output
OPTS	Causes values for all options to be output
ACCT	Summary and accounting information is output at the end of all the analysis
WIDTH	Same as .WIDTH OUT = statement

**TABLE 6.2**  
**Options with Values**

Option	Effects	Unit	Default
DEFL	MOSFET channel length (L)	m	100u
DEFW	MOSFET channel width (W)	m	100u
DEFAD	MOSFET drain diffusion area (AD)	M <sup>-2</sup>	0
DEFAS	MOSFET source diffusion area (AS)	M <sup>-2</sup>	0
TNOM	Default temperature (also the temperature at which model parameters are assumed to have been measured)	°C	27
NUMDGT	Number of digits output in print tables		4
CPTIME	Central processing unit (CPU) time allowed for a run	sec	1E6
LIMPTS	Maximum points allowed for any print table or plot		201
ITL1	DC and bias-point “blind” iteration limit		40
ITL2	DC and bias-point “educated guess” iteration limit		20
ITL4	Iteration limit at any point in transient analysis		10
ITL5	Total iteration limit for all points in transient analysis (ITL 5 = 0 means ITL5 = infinite)		5000
RELTOL	Relative accuracy of voltages and currents		0.001
TRTOL	Transient analysis accuracy adjustment		7.0
ABSTOL	Best accuracy of currents	A	1pA
CHGTOL	Best accuracy of charges	C	0.01pC
VNTOL	Best accuracy of voltages	V	1uV
PIVREL	Relative magnitude required for pivot in matrix solution		1E-13
GMIN	Minimum conductance used for any branch	Ω <sup>-1</sup>	1E-12

.TF            Small-signal transfer function

.DC            Dc sweep

In PSpice Schematics, these commands can be invoked from the Analysis type menu of the Simulation Settings as shown in [Figure 6.12](#).

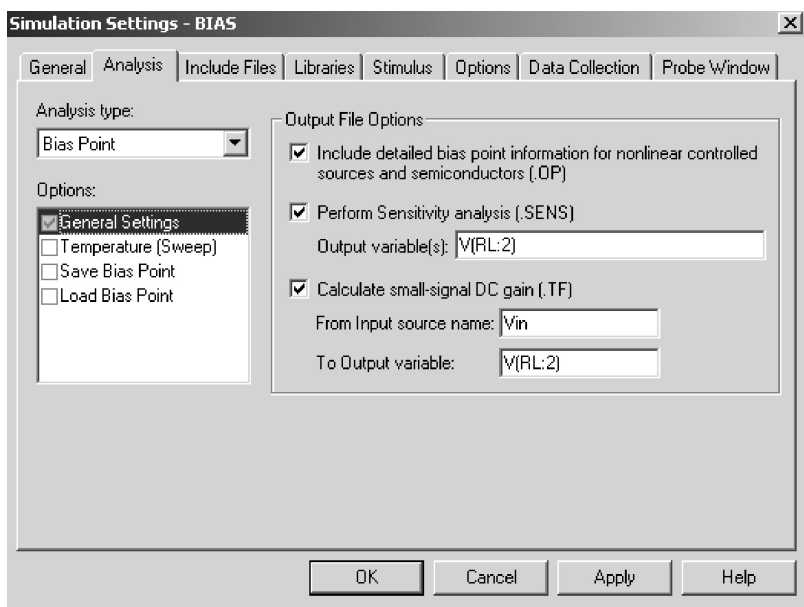


FIGURE 6.12 Setup for .OP, .TF, and .SENS commands.

### 6.6.1 .OP (OPERATING POINT)

Electronic and electrical circuits contain nonlinear devices (e.g., diodes, transistors) whose parameters depend on the *operating point*. The operating point is also known as a *bias point* or *quiescent point*. The operating point is always calculated by PSpice for determining small-signal parameters of nonlinear devices during the DC sweep and transfer function analysis. The command takes the form

```
.OP
```

In PSpice Schematics, this command can be invoked from Bias Point menu as shown in Figure 6.12.

The .OP command controls the output of the bias point, but not the method of bias analysis or the results of the bias point. If the .OP command is omitted, PSpice prints only a list of the node voltages. If the .OP command is present, PSpice prints the currents and power dissipations of all the voltages. The small-signal parameters of all nonlinear controlled sources and all semiconductor devices are also printed.

### 6.6.2 .NODESET (NODESET)

In calculating the operating bias point, some or all of the nodes of the circuit may be assigned initial guesses to help DC convergence by the statement

```
.NODESET V(1)=V1 V(2)=V2 ... V(N)=VN
```

$V(1)$ ,  $V(2)$ , ... are the node voltages, and  $V1$ ,  $V2$ , ... are their respective values of the initial guesses. Once the operating point is found, the `.NODESET` command has no effect during the DC sweep or transient analysis. This command may be necessary for convergence: for example, on flip-flop circuits to break the tie-in condition. In general, this command should not be necessary. One should not confuse this with the `.IC` command, which sets the initial conditions of the circuits during the operating point calculations for transient analysis. The `.IC` command is discussed in Subsection 6.9.1.

The statement for Nodeset is

```
.NODESET V(4)=1.5V V(6)=0V (25)=1.5V
```

### 6.6.3 .SENS (SENSITIVITY ANALYSIS)

The sensitivity of output voltages or currents with respect to every circuit and device parameter can be calculated by the `.SENS` statement, which has the general form

```
.SENS <(one or more output) variables>
```

In PSpice Schematics, this command can be invoked from Bias Point menu as shown in [Figure 6.12](#).

The `.SENS` statement calculates the bias point and the linearized parameters around the bias point. In this analysis, the inductors are assumed to be short circuits and capacitors to be open circuits. If the output variable is a current, that current must be through a voltage source. The sensitivity of each output variable with respect to all the device values and model parameters are calculated. The `.SENS` statement prints the results automatically. Therefore, it should be noted that a `.SENS` statement may generate a huge amount of data if many output variables are specified.

The statement for sensitivity analysis is

```
.SENS V(5) V(2,3) I(V2) I(V5)
```

#### EXAMPLE 6.2 FINDING THE SENSITIVITY OF THE OUTPUT VOLTAGE WITH RESPECT TO EACH CIRCUIT ELEMENT

An op-amp circuit is shown in [Figure 6.13](#). The op-amp is represented by the subcircuit of [Figure 6.2](#). Calculate and print the sensitivity of output voltage  $V(4)$  with respect to each circuit element. The operating temperature is  $40^{\circ}\text{C}$ .

#### SOLUTION

The PSpice schematic is shown in [Figure 6.14\(a\)](#). The output is specified in the Sensitivity Analysis menu of the Analysis Setup as shown in [Figure 6.14\(b\)](#).

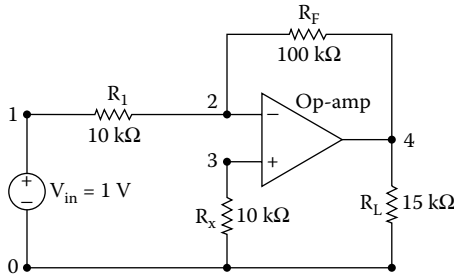
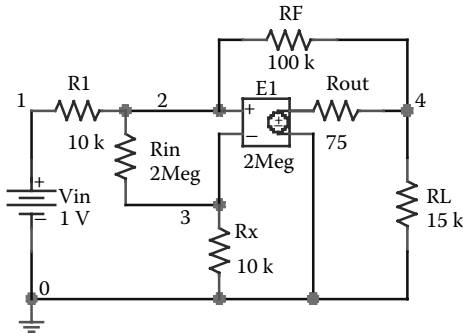
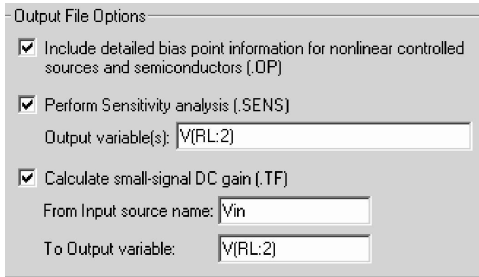


FIGURE 6.13 Op-amp circuit for Example 6.2.



(a)



(b)

FIGURE 6.14 PSpice schematic for Example 6.2. (a) Schematic, (b) defining the output of sensitivity analysis.

The listing of the statements for the circuit file is as follows:

**Example 6.2 DC sensitivity analysis**

```
SOURCE  ■ * DC input voltage of 1 V:
VIN 1 0 DC 1V
```

```

CIRCUIT ■■ R1 1 2 10K
              RF 2 4 100K
              RL 4 0 15K
              RX 3 0 10K
              * Subcircuit call OPAMP:
              X1 2 3 4 0 OPAMP
              * Subcircuit definition:
              .SUBCKT OPAMP 1 2 3 4
              * model name
              vi- vi+ vo+ vo-
              RIN 1 2 2MEG
              ROUT 5 3 75
              E1 5 4 2 1 2MEG ; Voltage-controlled voltage source
              .ENDS OPAMP ; End of subcircuit definition OPAMP
ANALYSIS ■■■ * Operating temperature is 40°C:
              .TEMP 40
              * Options:
              .OPTIONS NOPAGE NOECHO
              * It calculates and prints the sensitivity analysis of
              output
              * voltage V(4) with respect to all elements in the
              circuit.
              .SENS V(4)
              .END

```

---

The results of the sensitivity analysis are shown next. The node voltages are also printed automatically.

```

**** SMALL SIGNAL BIAS SOLUTION TEMPERATURE = 40.000 DEG C
NODE VOLTAGE NODE VOLTAGE NODE VOLTAGE NODE VOLTAGE
( 1) 1.0000 ( 2) 5.054E-06 ( 3) 25.14E-09 ( 4) -9.9999
(X1.5) -10.0570
VOLTAGE SOURCE CURRENTS
NAME CURRENT
VIN -1.000E - 04
TOTAL POWER DISSIPATION 1.00E - 04 WATTS
**** DC SENSITIVITY ANALYSIS TEMPERATURE = 40.000 DEG C
DC SENSITIVITIES OF OUTPUT V (4)

```

ELEMENT NAME	ELEMENT VALUE	ELEMENT SENSITIVITY (VOLTS/UNIT)	NORMALIZED SENSITIVITY (VOLTS/PERCENT)
R1	1.000E+04	1.000E-03	1.000E-01
RF	1.000E+05	-1.000E-04	-1.000E-01
RL	1.500E+04	-1.851E-11	-2.776E-09
RX	1.000E+04	2.766E-11	2.766E-09
X1.RIN	2.000E+06	-2.640E-13	-5.280E-09
X1.ROUT	7.500E+01	4.257E-09	3.193E-09
VIN	1.000E+00	-1.000E+01	-1.000E-01

### 6.6.4 .TF (SMALL-SIGNAL TRANSFER FUNCTION)

The small-signal transfer function capability of PSpice can be used to find the small-signal DC gain, the input resistance, and the output resistance of a circuit. If  $V(1)$  and  $V(4)$  are the input and output variables, respectively, PSpice will calculate the small-signal DC gain between nodes 1 and 4, defined by

$$A_v = \frac{\Delta V_o}{\Delta V_i} = \frac{V(4)}{V(1)}$$

as well as the input resistance between nodes 1 and 0 and the small-signal DC output resistance between nodes 4 and 0.

PSpice calculates the small-signal DC transfer function by linearizing the circuit around the operating point.

In PSpice Schematics, this command can be invoked from Bias Point menu as shown in [Figure 6.12](#). The statement for the transfer function has one of the forms

```
.TF VOUT VIN
.TF IOOUT IIN
```

where  $VIN$  is the input voltage.  $VOUT$  (or  $IOOUT$ ) is the output voltage (or output current). If the output is a current, the current must be through a voltage source. The output variable  $VOUT$  (or  $IOOUT$ ) has the same format and meaning as in a `.PRINT` statement. If there are inductors and capacitors in a circuit, the inductors are treated as short circuits and capacitors as open circuits.

The `.TF` command calculates the parameters of the Thévenin's (or Norton's) equivalent circuit of the circuit file. It prints the output automatically and does not require `.PRINT` or `.PLOT` or `.PROBE` statements.

Statements for transfer function analysis are

```
.TF V(VN) VIN
.TF I(VN) IIN
```

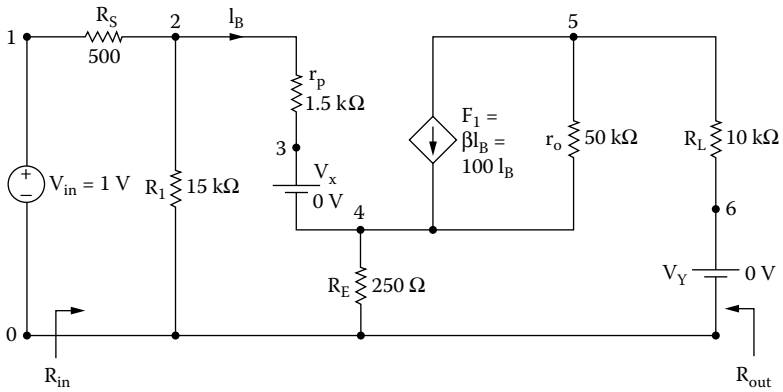


FIGURE 6.15 Amplifier circuit for Example 6.3.

**EXAMPLE 6.3 TRANSFER FUNCTION ANALYSIS OF AN AMPLIFIER CIRCUIT**

An amplifier circuit is shown in Figure 6.15. Calculate and print (a) the voltage gain  $A_v = V(5)/v_{in}$ , (b) the input resistance  $R_{in}$ , and (c) the output resistance  $R_o$ .

**SOLUTION**

The PSpice schematic is shown in Figure 6.16(a). The .TF command is set in the Analysis Setup. The output variable and the input source are identified in the TF set menu as shown in Figure 6.16(b).

The listing of the circuit file is as follows:

---

**Example 6.3 Transfer function analysis**

```

SOURCE  ■ * DC input voltage of 1 V:
          VIN  1  0  DC  1V
CIRCUIT  ■■ RS  1  2  500
          R1  2  0  15K
          RP  2  3  1.5K
          RE  4  0  250
          * Current-controlled current source:
          F1  5  4  VX  100
          R0  5  4  50K
          RL  5  6  10K
          * Dummy voltage source to measure the controlling
          current:
          VX  3  4  DC  0V
          * Dummy voltage source to measure the output current:
          VY  6  0  DC  0V
    
```

```

ANALYSIS ■■■ * The .TF command calculates and prints the DC gain and
               * the input and output resistances. The input voltage
               * is VIN and the output voltage is V (5).
               .TF V(5) VIN
               END.

```

---

The results of the .TF command are shown next.

```

VOLTAGE SOURCE CURRENTS
NAME          CURRENT
VIN           -1.053E-04
VX            4.211E-05
VY           -3.495E-03
TOTAL POWER DISSIPATION  1.05E-04 WATTS
****          SMALL-SIGNAL CHARACTERISTICS
V (5)/VIN = -3.495E+01
INPUT RESISTANCE AT VIN = 9.499E+03
OUTPUT RESISTANCE AT V (5) = 9.839E+03

```

The input resistance can be calculated as

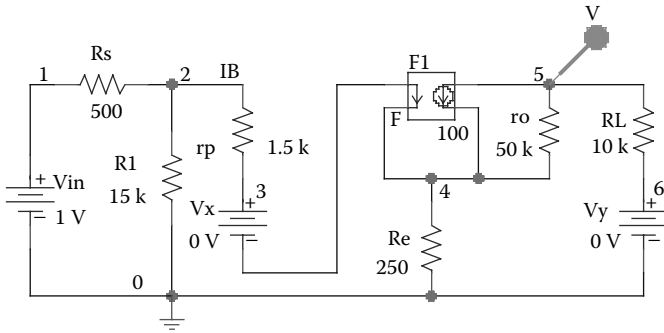
$$\begin{aligned}
 R_{in} &= R_s + R_i \parallel \left[ r_p + (1 + \beta_f) R_e \right] \\
 &= 500 + 15k \parallel \left[ 1.5k + (1 + 100) \times 250 \right] = 10.1k\Omega
 \end{aligned}$$

The voltage gain can be calculated as

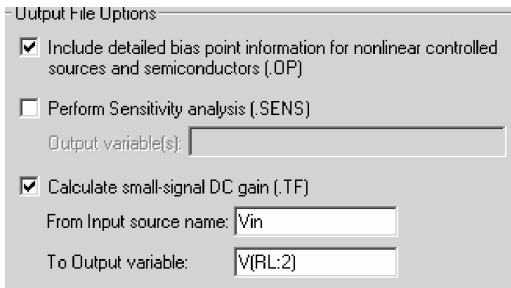
$$\begin{aligned}
 A_v &= \frac{-\beta_f R_L}{r_p + (1 + \beta_f) R_e} \times \frac{R_i \parallel \left[ r_p + (1 + \beta_f) R_e \right]}{R_{in}} \\
 &= \frac{-100 \times 10k}{1.5k + (1 + 100) \times 250} \times \frac{15k \parallel \left[ 1.5k + (1 + 100) \times 250 \right]}{10.1k} = -35.53 \text{ V/V}
 \end{aligned}$$

The output resistance can be approximately calculated as

$$R_o \approx R_L = 10 \text{ k}\Omega$$



(a)



(b)

**FIGURE 6.16** PSpice schematic for Example 6.3. (a) Schematic, (b) TF setup.

### 6.6.5 .DC (DC SWEEP)

DC sweep is also known as the *DC transfer characteristic*. The input variable is varied over a range of values. For each value of input variables, the DC operating point and the small-signal DC gain are computed by calling the small-signal transfer function capability of PSpice. The DC sweep (or DC transfer characteristic) is obtained by repeating the calculations of small-signal transfer function for a set of values.

An example of the DC Sweep setup in PSpice Schematics is shown in [Figure 6.17](#), and the nested sweep is set from the Secondary Sweep menu.

The statement for performing DC sweep takes one of the following general forms:

```
.DC LIN SWNAME SSTART SEND SINC
+ [(nested sweep specification)]
.DC OCT SWNAME SSTART SEND NP
+ [(nested sweep specification)]
```

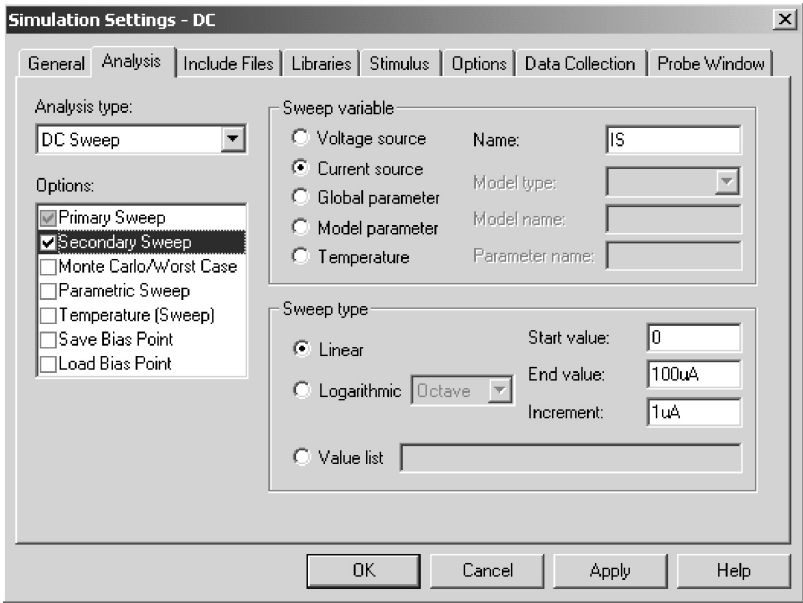


FIGURE 6.17 DC Sweep in PSpice Schematics.

```
.DC DEC SWNAME SSTART SEND NP
+      [(nested sweep specification)]
.DC SWNAME LIST <value>*
+      [(nested sweep specification)]
```

SWNAME is the sweep variable name. SSTART, SEND, and SINC are the start value, the end value, and the increment value of the sweep variables, respectively. NP is the number of steps. LIN, OCT, or DEC specifies the type of sweep, as follows:

- LIN *Linear sweep:* SWNAME is swept linearly from SSTART to SEND. SINC is the step size.
- OCT *Sweep by octave:* SWNAME is swept logarithmically by octave, and NP becomes the number of steps per octave. The next variable is generated by multiplying the present value by a constant larger than unity. OCT is used if the variable range is wide.
- DEC *Sweep by decade:* SWNAME is swept logarithmically by decade, and NP becomes the number of steps per decade. The next variable is generated by multiplying the present value by a constant larger than unity. DEC is used if the variable range is widest.
- LIST *List of values:* There are no start and end values. The values of the sweep variables are listed after the keyword LIST.

The SWNAME can be one of the following types:

*Source:* name of an independent voltage or current source. During the sweep, the source's voltage or current is set to the sweep value.

*Model parameter:* model name type and model name followed by a model parameter name in parentheses. The parameter in the model is set to the sweep value. The model parameters L and W for a MOS device and any temperature parameters such as TC1 and TC2 for the resistor cannot be swept.

*Temperature:* keyword TEMP followed by the keyword LIST. The temperature is set to the sweep value. For each value of sweep, the model parameters of all circuit components are updated to that temperature.

*Global parameter:* keyword PARAM followed by parameter name. The parameter is set to sweep. During the sweep, the global parameter's value is set to the sweep value and all expressions are evaluated.

The DC sweep can be nested, similar to a DO loop within a DO loop in FORTRAN programming. The first sweep will be the inner loop and the second sweep is the outer loop. The first sweep will be done for each value of the second sweep. <nested sweep specification> follows the same rules as those for the main (sweep variable).

The statements for DC sweep are

```
.DC VIN -5V 10V 0.25V
```

sweeps the voltage VIN linearly.

```
.DC LIN IIN 50MA -50MA 1MA
```

sweeps the current IIN linearly.

```
.DC VA 0 15V 0.5V IA 0 1MA 0.05MA
```

sweeps the current IA linearly within the linear sweep of VA.

```
.DC RES RMOD(R) 0.9 1.1 0.001
```

sweeps the model parameter R of the resistor model RMOD linearly.

```
.DC DEC NPN QM(IS)1E-18 1E-14 10
```

sweeps with a decade increment the parameter IS of the NPN transistor.

```
.DC TEMP LIST 0 50 80 100 150
```

sweeps the temperature TEMP as listed values.

```
.DC PARAM Vsupply -15V 15V 0.5V
```

sweeps the parameter PARAM Vsupply linearly.

PSpice does not print or plot any output by itself for DC sweep. The results of DC sweep are obtained by .PRINT, .PLOT, or .PROBE statements. Probe allows nested sweeps to be displayed as a family of curves.

Note the following:

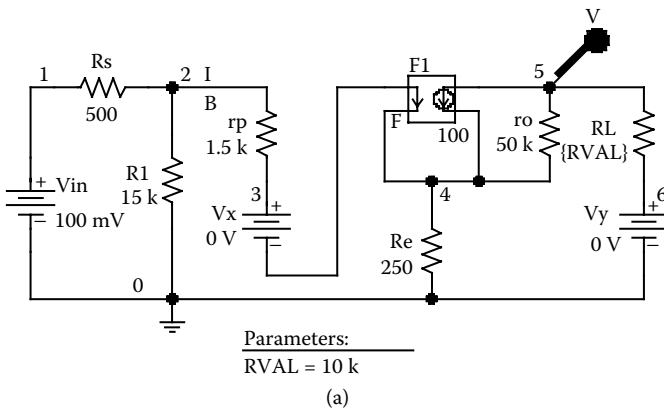
1. If the source has a DC value, its value is set by the sweep overriding the DC value.
2. In the third statement, the current source IA is the inner loop and the voltage source VA is the outer loop. PSpice will vary the value of current source IA from 0 to 1 mA with an increment of 0.05 mA for each value of voltage source VA, and generate an entire print table or plot for each value of voltage sweep.
3. The sweep-start value SSTART may be greater than or less than the sweep-end value SEND.
4. The sweep increment SINC must be greater than zero.
5. The number of points NP must be greater than zero.
6. After the DC sweep is finished, the sweep variable is set back to the value it had before the sweep started.

**EXAMPLE 6.4 DC TRANSFER CHARACTERISTIC OF VARYING THE LOAD RESISTOR**

For the amplifier circuit of Figure 6.15, calculate and plot the DC transfer characteristic,  $V_o$  vs.  $V_{in}$ . The input voltage is varied from 0 to 100 mV with an increment of 2 mV. The load resistance is varied from 10 kΩ to 30 kΩ with a 10-kΩ increment.

**SOLUTION**

The PSpice schematic is shown in Figure 6.18(a). By enabling Bias Points from the PSpice menu, the node voltages and branch currents can also be displayed. Defining the load resistance  $R_L$  as a parameter {RVAL} as shown in Figure 6.18(b) varies its value. The sweep variable  $V_{in}$  is set from the primary sweep menu as shown in Figure 6.18(c).



**FIGURE 6.18** PSpice schematic for Example 6.4. (a) Schematic, (b) setting PARAM values, (c) setting sweep variable.

Reference	Value	RVAL	Source Part
1	PARAM	10k	PARAM.Normal

(b)

Sweep variable

Voltage source      Name:   
 Current source      Model type:   
 Global parameter      Model name:   
 Model parameter      Parameter name:   
 Temperature

Sweep type

Linear      Start value:   
 Logarithmic      Decade      End value:   
 Value list      Increment:   
 Value list

(c)

FIGURE 6.18 (continued).

The listing of the circuit file is as follows:

### Example 6.4 DC sweep

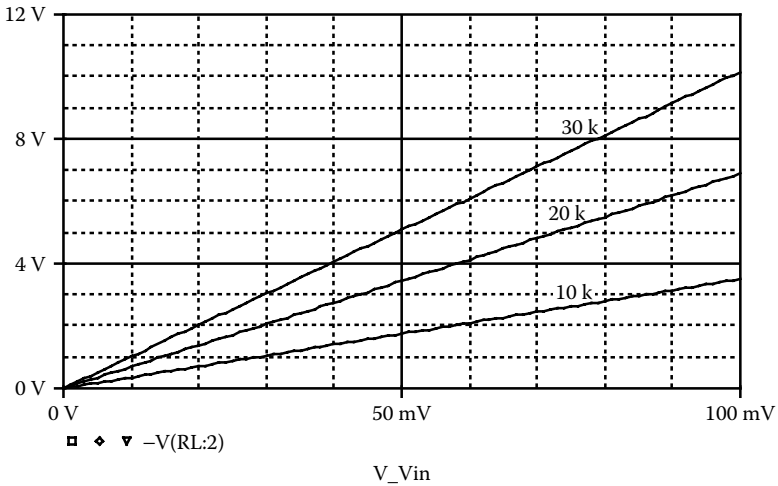
```

SOURCE ■ VIN 1 0 DC 100MV
CIRCUIT ■■ * Parameter definition for VAL:
          .PARAM RVAL =10K
          * Step variation for RVAL:
          .STEP PARAM RVAL 10K 30K 10K
          * Vary the load resistance RL:
          RL 5 6 {RVAL}
          RS 1 2 500
          R1 2 0 15K
          RP 2 3 1.5K
          RE 4 0 250
          * Current-controlled current source:
          F1 5 4 VX100
          R0 5 4 50K
          *RL 5 6 10K
  
```

```

* Dummy voltage source to measure the controlling
current:
VX 3 4 DC 0V
* Dummy voltage source to measure the output current:
VY 6 0 DC 0V
ANALYSIS ■■■ * DC sweep from 0 to 100 mV with an increment of 2 mV:
.DC VIN 0 100MV 1mV
* PSpice plots the results of DC sweep.
.PLOT DC V(5)
.PROBE ; Graphics post-processor
.END

```



**FIGURE 6.19** DC transfer characteristic for Example 6.4.

The transfer characteristic is shown in Figure 6.19.

## 6.7 AC ANALYSIS

The AC analysis calculates the frequency response of a circuit over a range of frequencies. If the circuit contains nonlinear devices or elements, it is necessary to obtain the small-signal parameters of the elements before calculating the frequency response. Prior to the frequency response (or AC analysis), PSpice determines the small-signal parameters of the elements. The method for calculation of bias point for AC analysis is identical to that for DC analysis. The details of the bias points can be printed by an `.OP` command.

The AC analysis is set at the Analysis menu as shown in Figure 6.20 and its specifications are set at the AC sweep menu. The noise analysis (discussed in Section 6.13) can also be enabled.

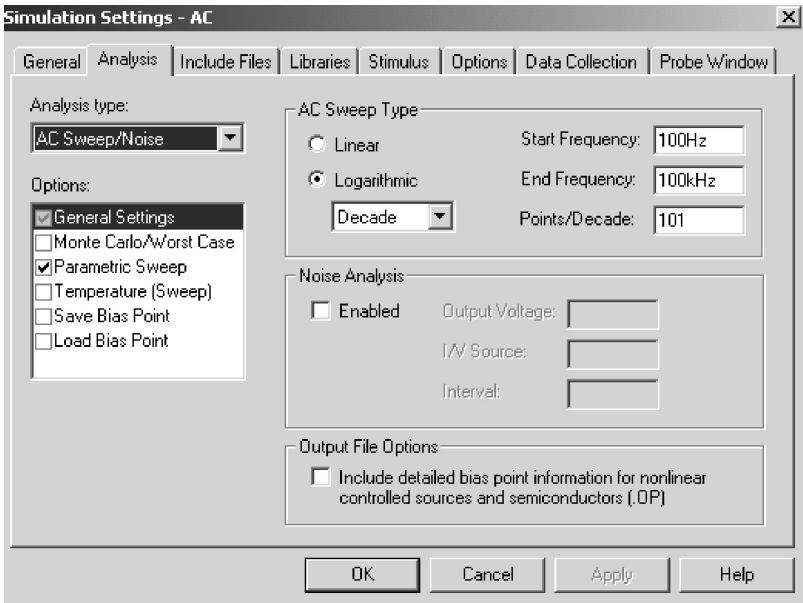


FIGURE 6.20 AC Analysis setup and sweep specifications.

The command for performing frequency response takes one of the general forms

```
.AC LIN NP FSTART FSTOP
.AC OCT NP FSTART FSTOP
.AC DEC NP FSTART FSTOP
```

NP is the number of points in a frequency sweep. FSTART is the starting frequency, and FSTOP is the ending frequency. Only one of LIN, OCT, or DEC must be specified in the statement. LIN, OCT, or DEC specifies the type of sweep as follows:

- LIN *Linear sweep:* The frequency is swept linearly from the starting frequency to the ending frequency, and NP becomes the total number of points in the sweep. The next frequency is generated by adding a constant to the present value. LIN is used if the frequency range is narrow.
- OCT *Sweep by octave:* The frequency is swept logarithmically by octave, and NP becomes the number of points per octave. The next frequency is generated by multiplying the present value by a constant larger than unity. OCT is used if the frequency range is wide.
- DEC *Sweep by decade:* The frequency is swept logarithmically by decade, and NP becomes the number of points per decade. DEC is used if the frequency range is widest.

PSpice does not print or plot any output by itself for AC analyses. The results of AC sweep are obtained by .PRINT, .PLOT, or .PROBE statements.

Some statements for AC analysis are

```
.AC LIN 20 100HZ 300HZ
.AC LIN 1 60HZ 120HZ
.AC OCT 10 100HZ 10KHZ
.AC DEC 100 1KHZ 1MEGHZ
```

Note the following:

1. FSTART must be less than FSTOP and must not be zero.
2. NP = 1 is permissible and the second statement calculates the frequency response at 60 Hz only.
3. Before performing the frequency response analysis, PSpice calculates, automatically, the biasing point to determine the linearized circuit parameters around the bias point.
4. All independent voltage and current sources that have AC values are inputs to the circuit. At least one source must have AC value; otherwise, the analysis would not be meaningful.
5. If a group delay output is required by a “G” suffix, as noted in Section 3.3, the frequency steps should be small, so that the output changes smoothly.

### EXAMPLE 6.5 FINDING THE PARAMETRIC EFFECT ON THE FREQUENCY RESPONSE OF AN RLC CIRCUIT

An RLC circuit is shown in Figure 6.21. Plot the frequency response of the current through the circuit and the magnitude of the input impedance. The frequency of the source is varied from 100 Hz to 100 kHz with a decade increment and 10 points per decade. The values of the inductor  $L$  are 5, 15, and 25 mH.

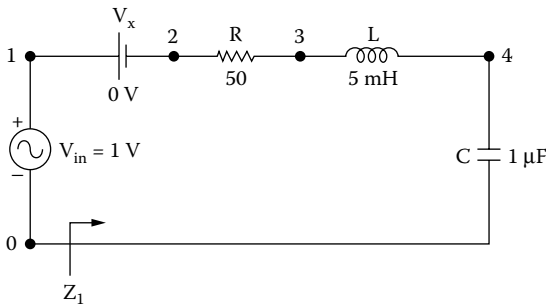
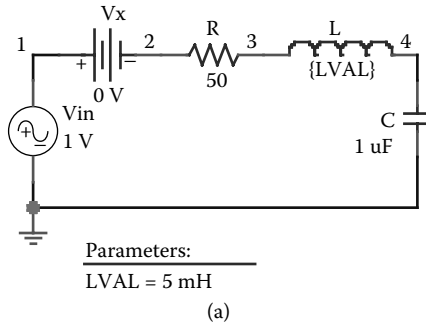
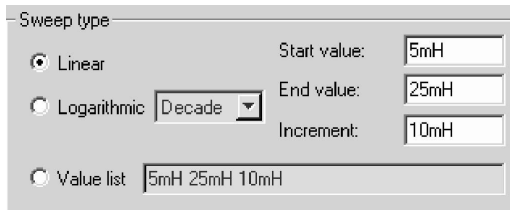
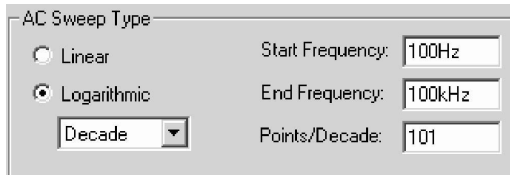


FIGURE 6.21 RLC circuit for Example 6.5.



Reference	Value	LVAL	Source Part
PM1	PARAM	5mH	PARAM.Normal



**FIGURE 6.22** PSpice schematic for Example 6.5. (a) Schematic, (b) setting PARAM values, (c) setting sweep variable, (d) setting sweep variable.

**SOLUTION**

The PSpice schematic is shown in Figure 6.22(a). By enabling Bias Points from the PSpice menu, the node voltages and branch currents can also be displayed. Defining the inductance L as a parameter {LVAL} as shown in Figure 6.22(b) varies its value. The AC sweep variable is set from the primary sweep menu as shown in Figure 6.22(c). LVAL is varied from the secondary sweep as shown in Figure 6.22(d).

The listing of the circuit file is as follows:

---

### Example 6.5 Input impedance characteristics

```

SOURCE   ■ VIN 1 0 AC 1V
CIRCUIT  ■■ * Parameter definition for VAL
            .PARAM VAL = 5MH
            * Step variation for VAL:
            .STEP   PARAM LVAL 5MH 25MH 10MH
            R 3 5 50
            * Vary the inductor:
            L 3 4 {LVAL}
            C 4 0 1UF
            * Dummy voltage source to measure the controlling
            current:
            VX 1 2 DC 0V
ANALYSIS ■■■ * AC sweep from 100 Hz to 100 kHz with 10 points per
            decade
            .AC DEC 10 100HZ 100KHZ
            * PSpice plots the results of a DC sweep.
            .PLOT AC V(1)           ; Plot on the output file
            .PROBE                  ; Graphics post-processor
            .END

```

---

The frequency response of the current through the circuit and the magnitude of the input impedance are shown in [Figure 6.23](#). As the inductance is increased, the resonant frequency is decreased.

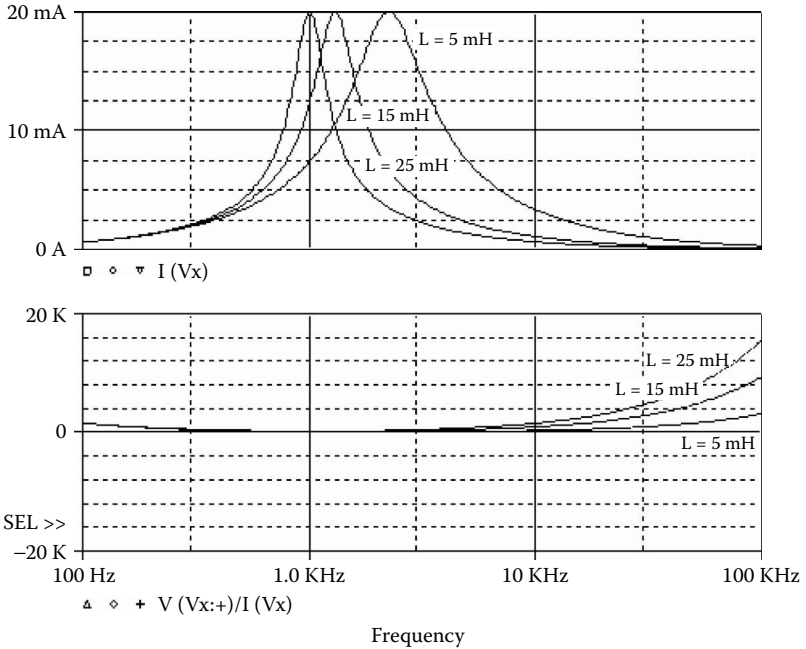
## 6.8 NOISE ANALYSIS

Resistors and semiconductor devices generate various types of noise [3]. The level of noise depends on the frequency. Noise analysis is performed in conjunction with AC analysis and requires an `.AC` command. For each frequency of the AC analysis, the noise level of each generator in a circuit (e.g., resistors, transistor) is calculated, and their contributions to the output nodes are computed by summing the rms noise values. The gain from the input source to the output voltage is calculated. From this gain the equivalent input noise level at the specified source is calculated by PSpice.

The statement for performing noise analysis is of the form

```
.NOISE V(N+, N-) SOURCE M
```

where  $V(N+, N-)$  is the output voltage across nodes  $N+$  and  $N-$ . The output such as  $V(N)$  could be at a node  $N$ . `SOURCE` is the name of an independent voltage



**FIGURE 6.23** Frequency response for Example 6.5.

or current source at which the equivalent input noise will be generated. It should be noted that SOURCE is not a noise generator, rather, it is where the equivalent noise input must be computed. For a voltage source, the equivalent input is in  $V/\sqrt{Hz}$ , and for a current source, it is in  $A/\sqrt{Hz}$ .

M is the print interval that permits one to print a table for the individual contributions of all generators to the output nodes for every *m*th frequency. The output noise and equivalent noise of individual contributions are printed by a .PRINT or .PLOT command. If the value of M is not specified, PSpice does not print a table of individual contributions. But PSpice prints automatically a table of total contributions rather than individual contributions.

In PSpice Schematics, noise analysis is enabled in the AC Sweep menu of the analysis setup as shown in Figure 6.24.

The statements for noise analysis are

```
.NOISE V(4,5) VIN
.NOISE V(6) IIN
.NOISE V(10) V1 10
```

*Note:* The .PROBE command cannot be used for noise analysis.

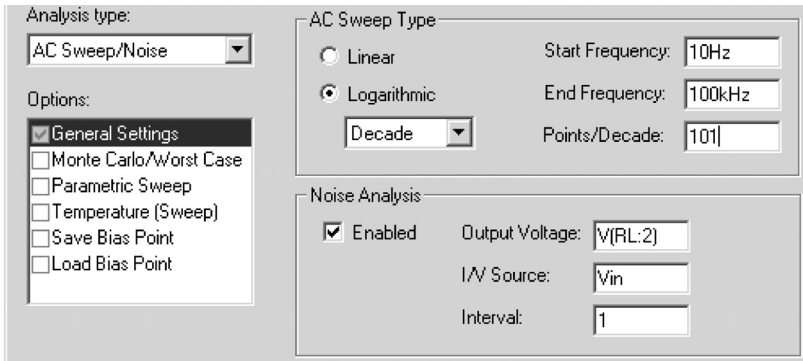


FIGURE 6.24 Noise Analysis menu.

### EXAMPLE 6.6 FINDING THE EQUIVALENT INPUT AND OUTPUT NOISE

For the circuit of Figure 6.13, calculate and print the equivalent input and output noise. The frequency of the source is varied from 1 Hz to 100 kHz. The frequency should be increased by a decade with 1 point per decade.

#### SOLUTION

The PSpice schematic is shown in Figure 6.25(a). Noise analysis, which follows AC analysis, is selected from the AC Sweep menu of the analysis setup as shown in Figure 6.25(b).

The input source is of the AC type. The listing of the circuit file is as follows:

---

### Example 6.6 Noise analysis

**SOURCE** ■ \* AC input voltage of 1 V:

```
VIN 1 0 AC 1V
```

**CIRCUIT** ■■

```
R1 1 2 10K
```

```
RF 2 4 100K
```

```
RL 4 0 15K
```

```
RX 3 0 10K
```

```
* Subcircuit call OPAMP:
```

```
X1 2 3 4 0 OPAMP
```

```
* Subcircuit definition:
```

```
.SUBCKT OPAMP 1 2 3 4
```

```
* model name vi- vi+ vo+ vo-
```

```
RIN 1 2 2MEG
```

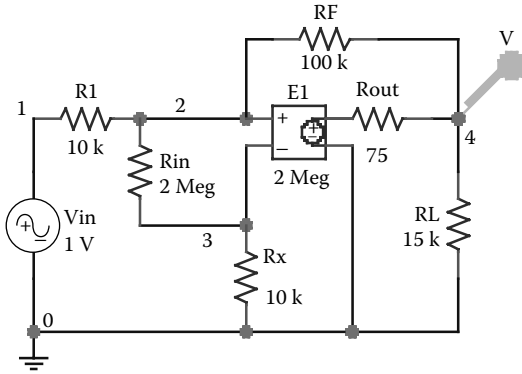
```
ROUT 5 3 75
```

```
E1 5 4 2 1 2MEG ; Voltage-controlled voltage  
source
```

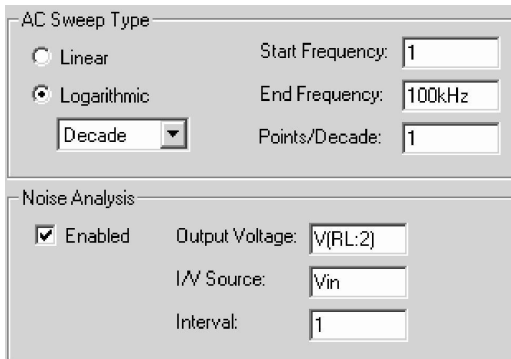
```
.ENDS OPAMP ; End of subcircuit definition  
OPAMP
```

```

ANALYSIS ■■■ * AC sweep from 1 Hz to 100 kHz with a decade increment
and 1 point
* per decade
.AC DEC 1 1HZ 100kHz
* Noise analysis without printing details of individual
contributions:
.NOISE V(4) VIN
* PSpice prints the details of equivalent input and
output noise.
.PRINT NOISE ONOISE INOISE
.END
    
```



(a)



(b)

**FIGURE 6.25** PSpice schematic for Example 6.6. (a) Schematic, (b) AC and Noise Analysis menu.

The results of the noise analysis are shown next.

```
****      AC ANALYSIS          TEMPERATURE = 27.000 DEG C
FREQ      ONOISE (V/ $\sqrt{\text{Hz}}$ )  INOISE (V/ $\sqrt{\text{Hz}}$ )
  1.000E+00  1.966E-07      1.966E-08
  1.000E+01  1.966E-07      1.966E-08
  1.000E+02  1.966E-07      1.966E-08
  1.000E+03  1.966E-07      1.966E-08
  1.000E+04  1.966E-07      1.966E-08
  1.000E+05  1.966E-07      1.966E-08
```

*Note:* We could combine the .AC, .NOISE, and .SEN V(4) commands in the circuit file of Example 6.2 by modifying the statement as follows

```
VIN 1 0 AC 1V DC 1V
```

## 6.9 TRANSIENT ANALYSIS

A transient response determines the output in the time domain in response to an input signal in the time domain. The method for the calculation of transient analysis bias point differs from that of DC analysis bias point. The DC bias point is also known as the *regular bias point*. In the regular (DC) bias point, the initial values of the circuit nodes do not contribute to the operating point or to the linearized parameters. The capacitors and inductors are considered open- and short-circuited, respectively, whereas in the transient bias point, the initial values of the circuit nodes are taken into account in calculating the bias point and the small-signal parameters of the nonlinear elements. The capacitors and inductors, which may have initial values, therefore, remain as parts of the circuit. Determination of the transient analysis requires statements involving

```
.IC      Initial transient conditions
.TRAN    Transient analysis
```

### 6.9.1 .IC (INITIAL TRANSIENT CONDITIONS)

The various nodes can be assigned to initial voltages during transient analysis, and the general form for assigning initial values is

```
.IC  V(1)=V1  V(2)=V2  ...  V(N)=VN
```

where  $V_1, V_2, V_3, \dots$  are the initial voltages for nodes  $V(1), V(2), V(3), \dots$ , respectively. These initial values are used by PSpice to calculate the transient analysis bias point and the linearized parameters of nonlinear devices for transient

analysis. After the transient analysis bias point has been calculated, the transient analysis starts and the nodes are released. It should be noted that these initial conditions do not affect the regular bias-point calculation during DC analysis or DC sweep. For the .IC statement to be effective, UIC (use initial conditions) should not be specified in the .TRAN command.

The statement for initial transient conditions is

```
.IC V(1)=2.5 V(5)=1.7 VV(7)=0.5
```

*Note:* In PSpice Schematics and OrCAD, the .IC command and UIC option may not be available.

### 6.9.2 .TRAN (TRANSIENT ANALYSIS)

Transient analysis can be performed by the .TRAN command, which has one of the general forms

```
.TRAN          TSTEP  TSTOP  [TSTART TMAX]  [UIC]
.TRAN[/OP]    TSTEP  TSTOP  [TSTART TMAX]  [UIC]
```

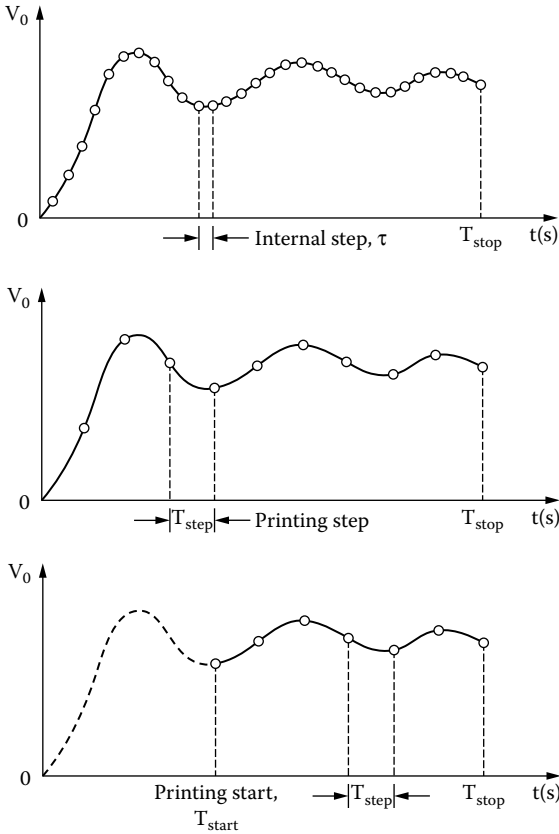
TSTEP is the printing increment, TSTOP is the final time (or stop time), and TMAX is the maximum step size of internal time step. TMAX allows the user to control the internal time step. TMAX could be smaller or larger than the printing time TSTEP. The default value of TMAX is TSTOP/50.

Transient analysis always starts at time  $t = 0$ . However, it is possible to suppress the printing of the output for a time TSTART. TSTART is the initial time at which the transient response is printed. In fact, PSpice analyzes the circuit from  $t = 0$  to TSTART, but it does not print or store the output variables. Although PSpice computes the results with an internal time step, the results are generated by interpolation for a printing step of TSTEP. [Figure 6.26](#) shows the relationships of TSTART, TSTOP, and TSTEP.

In transient analysis, only the node voltages of the transient analysis bias point are printed. However, the .TRAN command can control the output for the transient response bias point. An .OP command with a .TRAN command (i.e., .TRAN/OP) will print the small-signal parameters during transient analysis.

If UIC is not specified as optional at the end of a .TRAN statement, PSpice calculates the transient analysis bias point before the beginning of transient analysis. PSpice uses the initial values specified with the .IC command. If UIC (use initial conditions) is specified as an option at the end of a .TRAN statement, PSpice does not calculate the transient analysis bias point before the beginning of transient analysis. However, PSpice uses the initial values specified with the "IC=" initial conditions for capacitors and inductors, which are discussed in [Chapter 5](#). Therefore, if UIC is specified, the initial values of the capacitors and inductors must be supplied.

The .TRAN statements require .PRINT or .PLOT or .PROBE statements to obtain the results of the transient analysis.



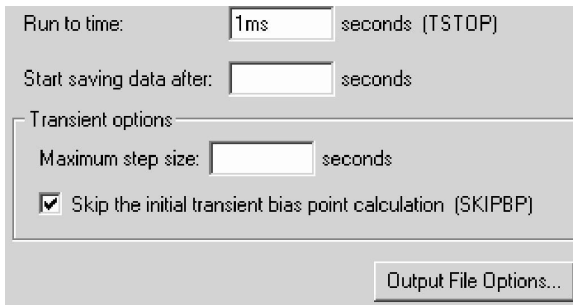
**FIGURE 6.26** Response of transient analysis.

Statements for transient analysis are

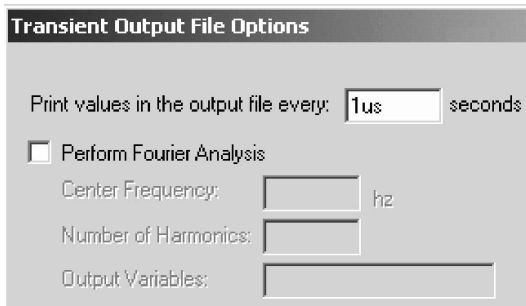
```
.TRAN      5US  1MS
.TRAN      5US  1MS  200US  0.1NS
.TRAN      5US  1MS  200US  0.1NS  UIC
.TRAN/OP   5US  1MS  200US  0.1NS  UIC
```

In PSpice Schematics, the Transient Analysis is selected from the Simulation Settings menu as shown in [Figure 2.6\(b\)](#). The run time is set from the General Setting menu as shown in [Figure 6.27\(a\)](#) and the print time is set from the Output files options as shown in [Figure 6.27\(b\)](#).

*Note:* In PSpice Schematics and OrCAD, the UIC option may not be available.



(a)



(b)

**FIGURE 6.27** Transient analysis setting. (a) General settings menu, (b) output file options.

### EXAMPLE 6.7 PLOTTING THE TRANSIENT RESPONSE OF AN *RLC* CIRCUIT WITH *.IC* COMMAND

Repeat Example 5.1, if the voltage across the capacitor is set by an *.IC* command instead of an *IC* condition, and *UIC* is not specified.

#### SOLUTION

In PSpice Schematics, assigning an initial value to the capacitor and setting the initial inductor current to zero can simulate the *.IC* command. This is shown in Figure 6.28.

The listing of the circuit file with *.IC* statement and without *UIC* is as follows:

---

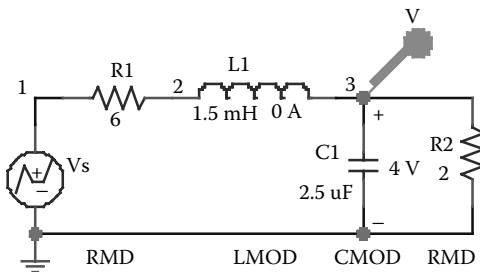
### Example 6.7 Transient response of RLC circuit

**SOURCE** ■ \* Input step voltage represented as an PWL waveform:  
 VS 1 0 PWL (0 0 10NS 10V 2MS 10V)

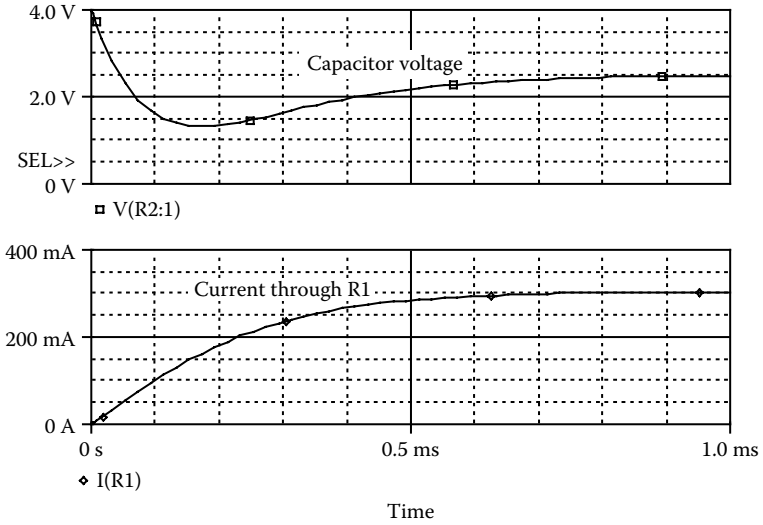
```

CIRCUIT ■■■ * R1 has a value of 6 Ω with model RMOD:
R1 1 2 RMOD 6
* Inductor of 1.5 mH with an initial current of 3 A
and model name LMOD:
L1 2 3 LMOD 1.5MH IC=3A
* Capacitor of 2.5 μF with an initial voltage of 4 V
and model name CMOD:
C1 3 0 CMOD 2.5UF IC=4V
R2 3 0 RMOD 2
* The initial voltage at node 3 is 4 V:
.IC V(3)=4V
* Model statements for resistor, inductor, and
capacitor:
.MODEL RMOD RES (R=1 TC1=0.02 TC2=0.005)
.MODEL CMOD CAP (C=1 VC1=0.01 VC2=0.002 TC1=0.02
TC2=0.005)
.MODEL LMOD IND (L=1 IL1=0.1 IL2=0.002 TC1=0.02
TC2=0.005)
* The operating temperature is 50°C:
.TEMP 50
ANALYSIS ■■■ * Transient analysis from 0 to 1 ms with a 1-μs time
increment and
* without using initial conditions (UIC): that is,
IC=4V has no effect
.TRAN 1MS 1MS
* Plot the results of transient analysis with voltage
at nodes 3 and 1.
.PLOT TRAN V(3) V(1)
.PROBE
.END

```



**FIGURE 6.28** PSpice schematic for Example 6.7.



**FIGURE 6.29** Transient response for Example 6.7.

The results of the simulation for the circuit of [Figure 6.28](#) are shown in [Figure 6.29](#). It may be noted that the response is completely different because of the assignment of an initial node voltage of 4 V on the capacitor.

## 6.10 FOURIER ANALYSIS

The output variables from the transient analysis are in discrete forms. These sampled data can be used to calculate the coefficients of Fourier series. A periodic waveform can be expressed in a Fourier series as

$$v(\theta) = C_0 + \sum_{n=1}^{\infty} C_n \sin(n\theta + \phi_n)$$

where

$$\theta = 2\pi ft$$

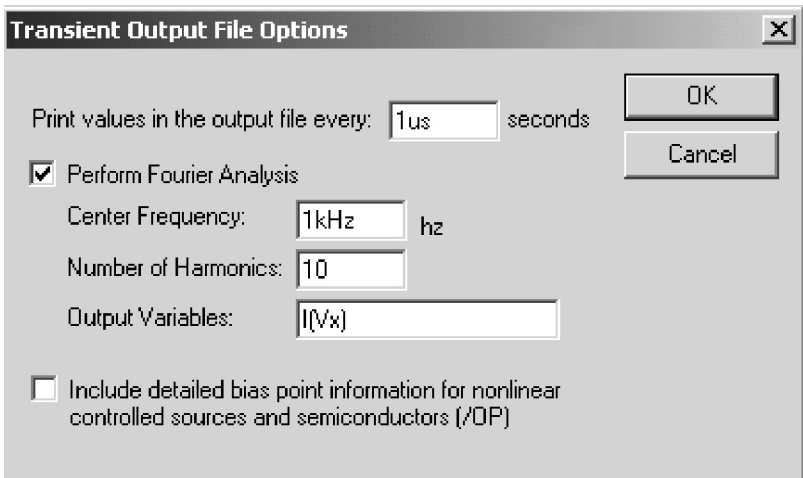
$f$  = frequency, in hertz

$C_0$  = DC component

$C_n$  =  $n$ th harmonic component

PSpice uses the results of transient analysis to perform Fourier analysis up to the ninth harmonic, or ten coefficients. The statement takes one of the general forms

```
.FOUR  FREQ  N  V1  V2  V3  ...  VN
.FOUR  FREQ  N  I1  I2  I3  ...  IN
```



**FIGURE 6.30** Fourier analysis menu.

FREQ is the fundamental frequency; V1, V2, ... (or I1, I2, ...) are the output voltages (or currents) for which the Fourier analysis is desired; N is the number of harmonics to be calculated. A .FOUR statement must have a .TRAN statement. The output voltages (or currents) must have the same forms as in the .TRAN statement for transient analysis.

Fourier analysis is performed over the interval TSTOP-PERIOD to TSTOP, where TSTOP is the final (or stop) time for the transient analysis and PERIOD is one period of the fundamental frequency. Therefore, the duration of the transient analysis must be at least one period, PERIOD. At the end of the analysis, PSpice determines the DC component and the amplitudes of up to the ninth harmonic (or ten coefficients) by default, unless N is specified.

PSpice prints a table automatically for the results of Fourier analysis and does not require .PRINT, .PLOT, or .PROBE statements.

In PSpice Schematics, Fourier analysis is enabled from the Output File Options of the Transient menu as shown in Figure 6.30.

Statement for Fourier analysis are

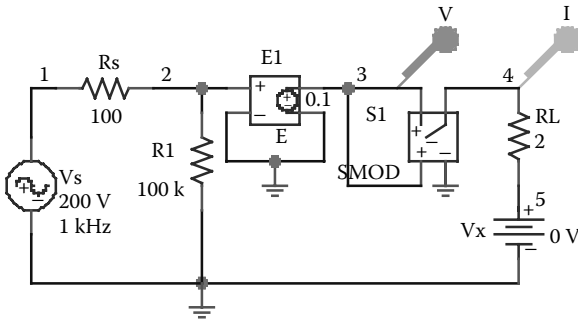
```
.FOUR 100KHZ V(2,3), V(3), I(R1), I(VIN)
```

### EXAMPLE 6.8 FINDING THE FOURIER COEFFICIENTS

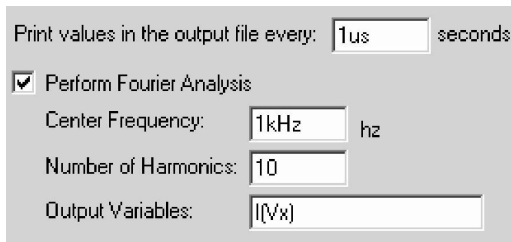
For the circuit in Example 5.5, calculate the coefficients of the Fourier series if the fundamental frequency is 1 kHz.

### SOLUTION

The PSpice schematic is shown in Figure 6.31(a). Fourier analysis, which is performed after transient analysis, is selected from the Output File options of the Transient Analysis menu as shown in Figure 6.31(b).



(a)



(b)

**FIGURE 6.31** PSpice schematic for Example 6.8. (a) Schematic, (b) Fourier menu.

The listing of the circuit file is as follows:

### Example 6.8 Fourier analysis

**SOURCE** ■ \* Sinusoidal input voltage of 200 V peak with 0° phase delay:

```
VS 1 0 SIN (0 200V 1KHZ)
```

**CIRCUIT** ■■ RS 1 2 1000HM

```
R1 2 0 100KOHM
```

\* Voltage-controlled voltage source with a voltage gain of 0.1:

```
E1 3 0 2 0 0.1
```

```
RL 4 5 20HM
```

\* Dummy voltage source of VX = 0 to measure the load current:

```
VX 5 0 DC 0V
```

\* Voltage-controlled switch controlled by voltage across nodes 3 and 0:

```
S1 3 4 3 0 SMOD
```

\* Switch model descriptions:

```
.MODEL SMOD VSWITCH (RON=5M ROFF=10E+9 VON=25M VOFF=0.0)
```

```

ANALYSIS ■■■ * Transient analysis from 0 to 1 ms with a 5- $\mu$ s
increment
.TRAN 5US 1MS
* Plot the current through VX and the input voltage.
.PLOT TRAN V(3) I(VX) ; On the output file
* Fourier analysis of load current at a fundamental
frequency of 1 kHz:
.FOUR 1KHZ I(VX) .PROBE ; Graphics post-processor
.END

```

It should be noted that we could add the statement `.FOUR 1KHZ I(VX)`, in the circuit file of Example 5.5. The results of Fourier analysis are shown in the following text.

---

### FOURIER COMPONENTS OF TRANSIENT RESPONSE I(VX)

DC COMPONENT = 3.171401E+00

Harmonic No	Frequency (Hz)	Fourier Component	Normalized Component	Phase (Deg)	Normalized Phase (Deg)
1	1.000E+03	4.982E+00	1.000E+00	2.615E-05	0.000E+00
2	2.000E+03	2.115E+00	4.245E-01	-9.000E+01	-9.000E+01
Harmonic No	Frequency (Hz)	Fourier Component	Normalized Component	Phase (Deg)	Normalized Phase (Deg)
3	3.000E+03	9.002E-08	1.807E-08	6.216E+01	6.216E+01
4	4.000E+03	4.234E-01	8.499E-02	-9.000E+01	-9.000E+01
5	5.000E+03	9.913E-08	1.990E-08	8.994E+01	8.994E+01
6	6.000E+03	1.818E-01	3.648E-02	-9.000E+01	-9.000E+01
7	7.000E+03	7.705E-08	1.547E-08	5.890E+01	5.890E+01
8	8.000E+03	1.012E-01	2.032E-02	-9.000E+01	-9.000E+01
9	9.000E+03	9.166E-08	1.840E-08	7.348E+01	7.348E+01

TOTAL HARMONIC DISTORTION = 4.349506E+01 PERCENT

---

After the Fourier analysis is completed, the Fourier spectrum shown in [Figure 6.32\(b\)](#) can be obtained by selecting Fourier from the Probe Trace menu as shown in [Figure 6.32\(a\)](#).

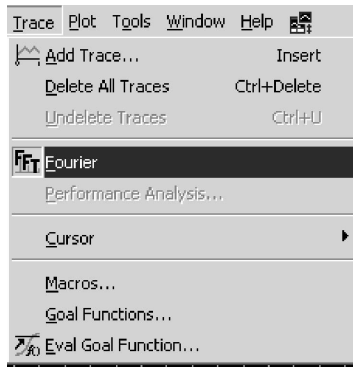
## 6.11 MONTE CARLO ANALYSIS

PSpice allows one to perform the Monte Carlo (statistical) analysis of a circuit. The general form of the Monte Carlo analysis is

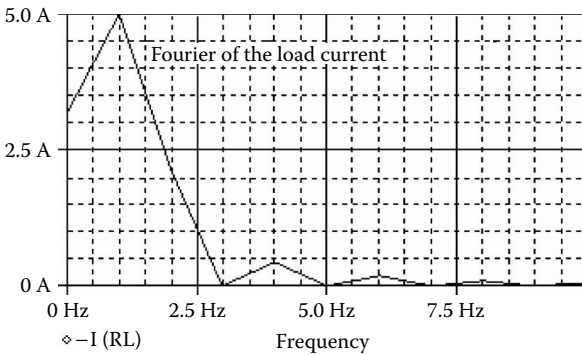
```

.MC <(# runs) value> <(analysis)> <(output variable)>
<(function)> + [(option)]*

```



(a)



(b)

**FIGURE 6.32** Fourier frequency spectrum for Example 6.8. (a) Selecting Fourier, (b) Fourier frequency spectrum.

This command performs multiple runs of the analysis selected (DC, AC, transient). The first run is with the nominal values of all components. Subsequent runs are with variations on model parameters as specified by DEV and LOT tolerances on each .MODEL parameter (Section 6.2).

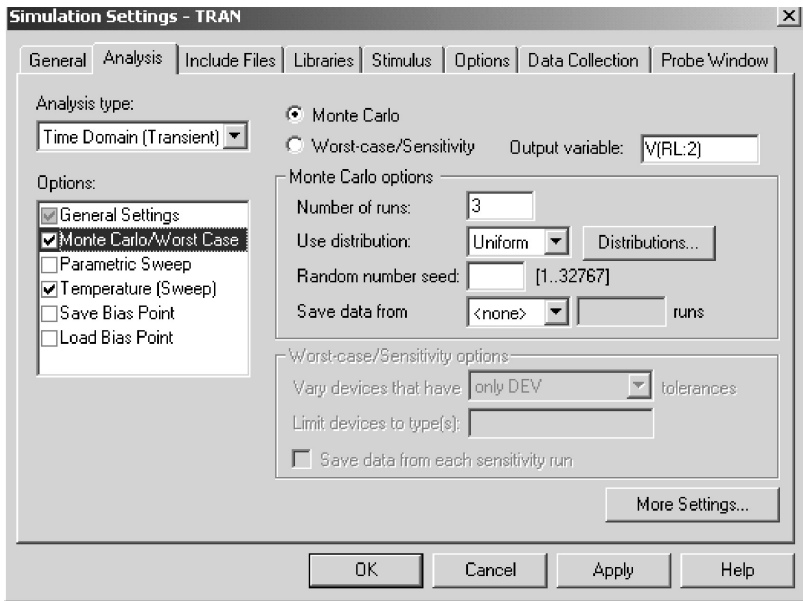
$\langle(\# \text{ runs}) \text{ value}\rangle$  is the total number of runs to be performed. For printed results, the upper limit is 2000. For the output to be viewed with Probe, the limit is 100;  $\langle(\text{analysis})\rangle$  must be specified from one of DC, AC, or transient analyses. This analysis will be repeated in subsequent passes. All analyses that the circuit contains are performed during the normal pass. Only the selected analysis is performed during subsequent passes.  $\langle(\text{output variable})\rangle$  is identical in format to that of a .PRINT output variable (in Chapter 3).

$\langle(\text{function})\rangle$  specifies the operation to be performed on the values of the  $\langle(\text{output variable})\rangle$ . This value is the basis for comparisons between the nominal and subsequent runs.  $\langle(\text{function})\rangle$  must be one of:

YMAX	Finds the greatest difference in each waveform from the nominal run.
MAX	Finds the maximum value of each waveform.
MIN	Finds the minimum value of each waveform.
RISE_EDGE (⟨value⟩)	Finds the first occurrence of the waveform crossing above the threshold ⟨value⟩. The waveform must have one or more points at or below ⟨value⟩ followed by one above. The output will be the value where the waveform increases above ⟨value⟩.
FALL_EDGE (⟨value⟩)	Finds the first occurrence of the waveform crossing below the threshold ⟨value⟩. The waveform must have one or more points at or below ⟨value⟩ followed by one below. The output will be the value where the waveform decreases below ⟨value⟩.

[(option)]\* may be zero for one of the following:

LIST	At the beginning of each run, prints out the model parameter values actually used for each component during that run.								
OUTPUT	(output type) requests output from subsequent runs after the nominal (first) run. The output for any run follows the .PRINT, .PLOT, and .PROBE statements in the circuit file. If OUTPUT is omitted, only the nominal run produces output. (output type) is one of the following: <table> <tr> <td>ALL</td> <td>Forces all output to be generated, including the nominal run.</td> </tr> <tr> <td>FIRST ⟨value⟩</td> <td>Generates output only during first <math>n</math> runs.</td> </tr> <tr> <td>EVERY ⟨value⟩</td> <td>Generates output every <math>n</math>th run.</td> </tr> <tr> <td>RUN ⟨value⟩*</td> <td>Does analysis and generates output only for the runs listed. Up to 25 values may be specified in the list.</td> </tr> </table>	ALL	Forces all output to be generated, including the nominal run.	FIRST ⟨value⟩	Generates output only during first $n$ runs.	EVERY ⟨value⟩	Generates output every $n$ th run.	RUN ⟨value⟩*	Does analysis and generates output only for the runs listed. Up to 25 values may be specified in the list.
ALL	Forces all output to be generated, including the nominal run.								
FIRST ⟨value⟩	Generates output only during first $n$ runs.								
EVERY ⟨value⟩	Generates output every $n$ th run.								
RUN ⟨value⟩*	Does analysis and generates output only for the runs listed. Up to 25 values may be specified in the list.								
RANGE	((⟨low value⟩, ⟨⟨high value⟩⟩) restricts the range over which ⟨⟨function⟩⟩ will be evaluated. An “*” can be used in place of a ⟨value⟩ to indicate “for all values.” Examples are: <table> <tr> <td>YMAX RANGE (*, 0.5)</td> <td>YMAX is evaluated for values of the sweep variable (time, frequency, etc.) of 0.5 or less.</td> </tr> <tr> <td>MAX RANGE (-1, *)</td> <td>The maximum value of the output variable is found for values of the sweep variable of -1 or more.</td> </tr> </table>	YMAX RANGE (*, 0.5)	YMAX is evaluated for values of the sweep variable (time, frequency, etc.) of 0.5 or less.	MAX RANGE (-1, *)	The maximum value of the output variable is found for values of the sweep variable of -1 or more.				
YMAX RANGE (*, 0.5)	YMAX is evaluated for values of the sweep variable (time, frequency, etc.) of 0.5 or less.								
MAX RANGE (-1, *)	The maximum value of the output variable is found for values of the sweep variable of -1 or more.								



**FIGURE 6.33** Monte Carlo or Worst-Case menu.

Some statements for Monte Carlo analysis are

```
.MC 10 TRAN V(2) YMAX
.MC 40 DC IC(Q3) YMAX LIST
.MC 20 AC VP(3,4) YMAX LIST OUTPUT ALL
```

In PSpice Schematics, the Monte Carlo or Worst-Case menu is selected from the Analysis Setup menu and the various options are shown in Figure 6.33.

### EXAMPLE 6.9 MONTE CARLO ANALYSIS OF AN *RLC* CIRCUIT

The *RLC* circuit as shown in Figure 6.28 is supplied with a step input voltage of 1V. The circuit parameters are:

$$R_1 = 4\Omega \pm 20\% \text{ (deviation/uniform)} \quad R_L = 500\Omega \pm 20\% \text{ (deviation/uniform)}$$

$$L_1 = 50\mu\text{H} \pm 15\% \text{ (deviation/uniform)} \quad C_1 = 1\mu\text{F} \pm 10\% \text{ (deviation/Gauss)}$$

The model parameters are: for the resistance,  $R = 1$ ; for the capacitor,  $C = 1$ ; and for the inductor,  $L = 1$ .

Use PSpice to perform Monte Carlo analysis of the capacitor voltage  $v_C$  from 0 to 160  $\mu\text{sec}$  with a time increment of 0.1  $\mu\text{sec}$  to find the following:

1. The greatest difference of the capacitor voltage from the nominal run to be printed for five runs
2. The first occurrence of the capacitor voltage crossing below 1 V to be printed

### SOLUTION

The PSpice schematic is shown in [Figure 6.34\(a\)](#). The options for the maximum deviation (YMAX) are selected from the Output file options, as shown in [Figure 6.34\(c\)](#), of the Monte Carlo menu as shown in [Figure 6.34\(b\)](#). The options for the time of the fall edge are shown in [Figure 6.34\(d\)](#).

The listing of the circuit file follows:

---

### Example 6.9 Monte Carlo analysis

```

VIN      1 0 PWL (0 0 1NS 1V 10MS 1V) ; Step input of 1 V
R1 1 2 Rbreak1 4 ; Resistance with model
          Rbreak1
L1 2 3 Lbreak1 50UH ; Inductance with model
          Lbreak1
C1 3 0 Cbreak1 1UF ; Capacitance with model
          Cbreak1
RL 3 0 Rbreak1 500
.MODEL Rbreak1 RES (R=1 DEV/UNIFORM=20%)
.MODEL Lbreak1 IND (L=1 DEV/UNIFORM=15%)
.MODEL Cbreak1 CAP (C=1 DEV/GAUSS=10%)
.TRAN 0.11US 160US ; Transient analysis
*.MC 5 TRAN V(3) YMAX ; Monte Carlo analysis
.MC 5 TRAN V(3) FALL_EDGE(1V) ; Monte Carlo analysis
.PROBE ; Graphical waveform analyzer
.END ; End of circuit file

```

---

Note the following:

- (a) The results of Monte Carlo analysis, which are obtained from the output file Example 6.9.out, are as follows:

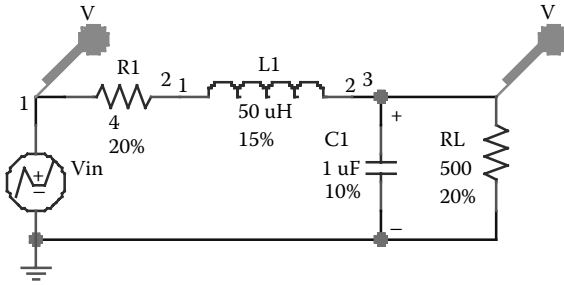
Mean Deviation = -.0462

Sigma = .0716

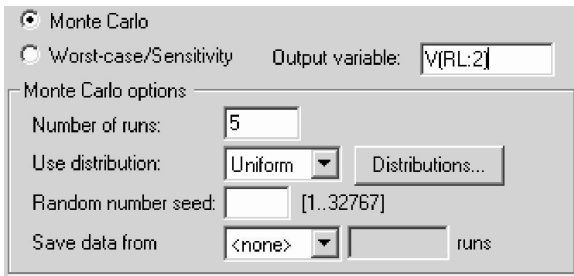
RUN MAX DEVIATION FROM NOMINAL

Pass 3.0958 (1.34 sigma) lower at T = 20.1100E-06  
(92.054% of nominal)

Pass 4.085 (1.19 sigma) lower at T = 36.1110E-06  
(92.59% of nominal)



(a)



(b)

**FIGURE 6.34** PSpice schematic for Example 6.9. (a) Schematic, (b) Monte Carlo menu, (c) setup for finding the greatest difference, (d) setup for finding the time of fall edge.

```

Pass 5.0816 (1.14 sigma) lower at T = 26.5110E-06
          (94.115% of nominal)
Pass 2.0774 (1.08 sigma) higher at T = 16.9100E-06
          (107.89% of nominal)
    
```

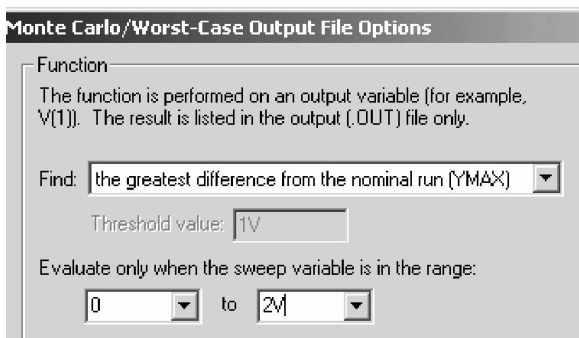
(b) To find the first occurrence of the capacitor voltage crossing below 1V, the .MC statement is changed as follows:

```
.MC 5 TRAN V(3) FALL_EDGE(1V) ;Monte-Carlo Analysis
```

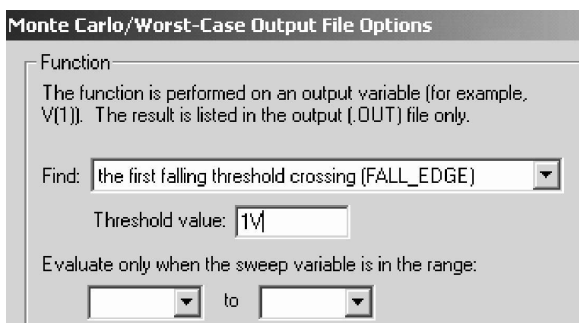
The results of the Monte Carlo analysis are shown below:

```

RUN      FIRST FALLING EDGE VALUE THRU 1
Pass 3   39.6120E-06
          (106.9% of nominal)
NOMINAL  37.0550E-06
Pass 5   36.9080E-06
          (99.603% of nominal)
    
```



(c)



(d)

**FIGURE 6.34** (continued).

```

Pass 2  34.9430E-06
        (94.3% of nominal)

Pass 4  34.6970E-06
        (93.635% of nominal)

```

## 6.12 SENSITIVITY AND WORST-CASE ANALYSIS

PSpice allows one to perform the sensitivity/worst-case analysis of a circuit for variations of model parameters. The variations are specified by DEV and LOT tolerances on model parameters. The general statement of the sensitivity/worst-case analysis is

```
.WCASE{(analysis)} {(output variable)}
      {(function)} {(option)}*
```

This command is similar to the `.MC` command, except that it does not include `{(# runs) value}`. With a `.WCASE` command, PSpice first calculates the sensitivity of all `{(output variable)}` to each model parameter. Once all the sensitivities are calculated, one final run is done with the sensitivities of the model parameters, and PSpice gives the worst-case `{(output variable)}`.

*Note:* Both the `.MC` and `.WCASE` commands cannot be selected at the same time. Only one command is to be used at a time.

Some statements for sensitivity/worst-case analysis are

```
.WCASE TRAN V(2) YMAX
.WCASE DC V(3) YMAX LIST
.WCASE AC VP(3,4) YMAX LIST OUTPUT ALL
```

### EXAMPLE 6.10 WORST-CASE ANALYSIS OF AN *RLC* CIRCUIT

Run the worst-case analysis for Example 6.9.

#### SOLUTION

The PSpice schematic as shown in [Figure 6.35\(a\)](#) is the same as that in [Figure 6.34\(a\)](#). The Worst-Case menu is shown in [Figure 6.35\(b\)](#). The option for the maximum deviation (YMAX) is selected from the Output File options, as shown in [Figure 6.34\(c\)](#), and the option for the time of the fall edge is shown in [Figure 6.34\(d\)](#).

- (a) To run the sensitivity/worst-case analysis greatest difference for the nominal run, the `.MC` statement in Example 6.9 is changed to a `.WCASE` statement as follows:

```
.WCASE TRAN V(3) YMAX ; Sensitivity/worst-case
analysis
```

The plots of the greatest difference and the nominal value are shown in [Figure 6.36](#). The results of worst-case, obtained from the output file Example 6.10.out, are as follows:

```
**** SORTED DEVIATIONS OF V(3) TEMPERATURE =
27.000 DEG C
```

#### WORST CASE SUMMARY

```
RUN          MAX DEVIATION FROM NOMINAL
ALL DEVICES  .206 higher at T = 16.9100E-06
              (120.98% of Nominal)
```

- (b) To find the first occurrence of the capacitor voltage crossing below 1 V, the `.WCASE` statement follows:

```
.WCASE TRAN V(3) FALL_EDGE (1V) ; Sensitivity/worst-
case analysis
```

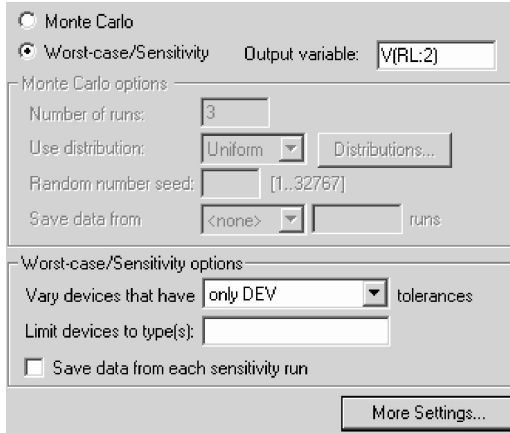
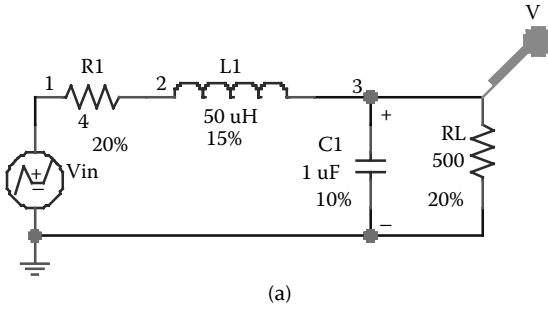


FIGURE 6.35 PSpice schematic for Example 6.10. (a) Schematic, (b) Worst-Case menu.

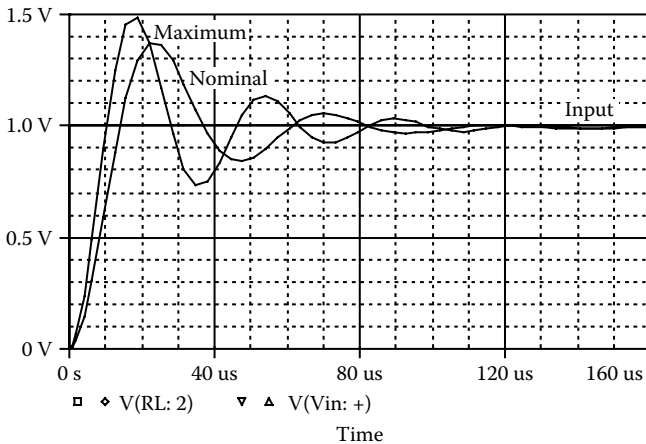
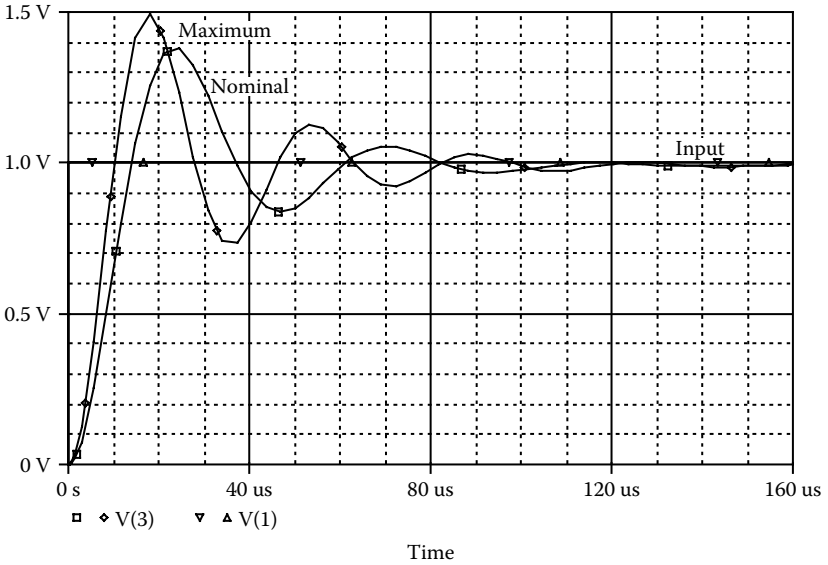


FIGURE 6.36 Plots of the greatest difference and the nominal run for Example 6.10.



**FIGURE 6.37** Plots of the first crossing below 1V and nominal run for Example 6.10.

The plots of the greatest difference and the nominal value are shown in Figure 6.37. The results of worst-case, obtained from the output file Example 6.10.out, are as follows:

```

****   SORTED DEVIATIONS OF V(3)  TEMPERATURE = 27.000
      DEG C

RUN           FIRST FALLING EDGE VALUE THRU1
NOMINAL       37.0550E-06
ALL DEVICES   31.8480E-06
              (85.947% of nominal)
    
```

## SUMMARY

The PSpice dot commands can be summarized as follows:

- .AC            AC analysis
- .DC           DC analysis
- .END          End of circuit
- .ENDS        End of subcircuit
- .FUNC        Function
- .FOUR        Fourier analysis
- .GLOBAL     Global
- .IC          Initial transient conditions
- .INC        Include file
- .LIB        Library file

.MC	Monte Carlo analysis
.MODEL	Model
.NODESET	Nodeset
.NOISE	Noise analysis
.OP	Operating point
.OPTIONS	Options
.PARAM	Parameter
.PLOT	Plot
.PRINT	Print
.PROBE	Probe
.SENS	Sensitivity analysis
.STEP	Step
.SUBCKT	Subcircuit definition
.TEMP	Temperature
.TF	Transfer function
.TRAN	Transient analysis
.WIDTH	Width

## Suggested Reading

1. P. Antognetti and G. Massobri, *Semiconductor Device Modeling with SPICE*, New York: McGraw-Hill, 1988.
2. M.H. Rashid, *Introduction to PSpice Using OrCAD for Circuits and Electronics*, 3rd ed., Englewood Cliffs, NJ: Prentice-Hall, 2003, chap. 6.
3. M.H. Rashid, *SPICE For Power Electronics and Electronic Power*, Englewood Cliffs, NJ: Prentice-Hall, 1993.
4. *PSpice Design Community*. San Jose, CA: Cadence Design Systems, 2001, <http://www.PSpice.com>.
5. *PSpice Models from Vendors*, <http://www.pspice.com/models/links.asp>.

## PROBLEMS

### 6.1

For the circuit in [Figure P6.1](#), calculate and print the sensitivity of output voltage  $V_o$  with respect to each circuit element. The operating temperature is 50°C.

### 6.2

For the circuit in [Figure P6.1](#), calculate and print (a) the voltage gain,  $A_v = V_o/V_{in}$ , (b) the input resistance,  $R_{in}$ , and (c) the output resistance,  $R_o$ .

### 6.3

For the circuit in [Figure P6.1](#), calculate and plot the DC transfer characteristic,  $V_o$  vs.  $V_{in}$ . The input voltage is varied from 0 to 10 V with an increment of 0.5 V.

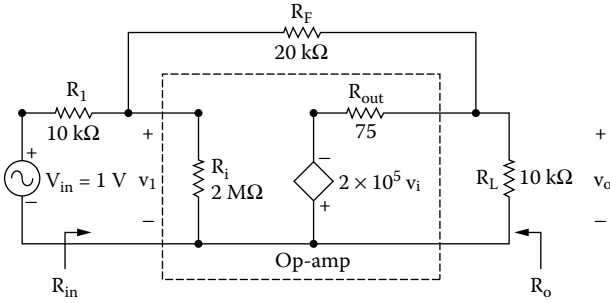


FIGURE P6.1 Amplifier circuit.

6.4

For the circuit in Figure P6.1, calculate and print the equivalent input and output noise if the frequency of the source is varied from 10 Hz to 1 MHz. The frequency should be increased by a decade with two points per decade.

6.5

For the circuit in Figure P6.5, the frequency response is to be calculated and printed over the frequency range from 1 Hz to 100 kHz with a decade increment and ten points per decade. The peak magnitude and phase angle of the output voltage is to be plotted on the output file. The results should also be available for display and as hard copy by using the .PROBE command.

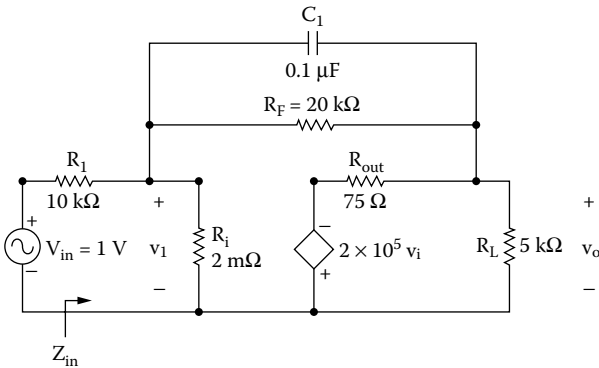


FIGURE P6.5 Integrator circuit.

6.6

Repeat Problem 6.5 for the circuit in Figure P6.6.

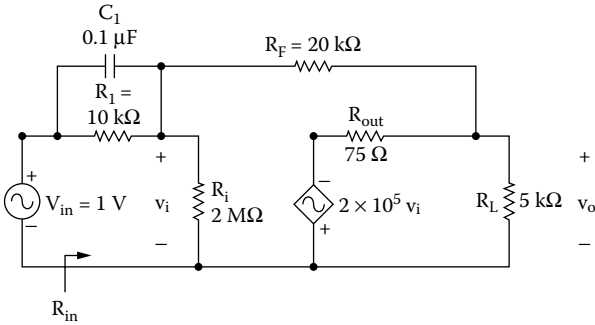


FIGURE P6.6 Low-pass filter circuit.

6.7

For the circuit in Figure P6.5, calculate and plot the transient response of the output voltage from 0 to 2 msec with a time increment of 5  $\mu\text{sec}$ . The input voltage is shown in Figure P6.7. The results should be available for display and as hard copy by using Probe.

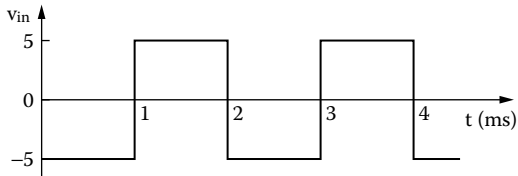


FIGURE P6.7 Pulse waveform.

6.8

Repeat Problem 6.7 for the input voltage shown in Figure P6.8.

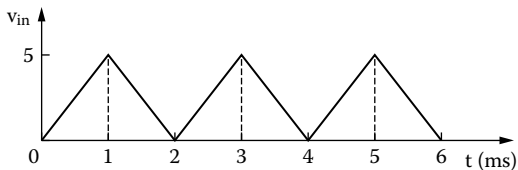


FIGURE P6.8 Triangular waveform.

## 6.9

For the circuit of [Figure P6.6](#), calculate and plot the transient response of the output voltage from 0 to 2 msec with a time increment of 5  $\mu$ sec. The input voltage is shown in [Figure P6.7](#). The results should be available for display and as hard copy by using Probe.

## 6.10

Repeat Problem 6.9 for the input voltage shown in [Figure P6.8](#).

## 6.11

For Problem 6.7, calculate the coefficients of the Fourier series if the fundamental frequency is 500 Hz.

## 6.12

For Problem 6.8, calculate the coefficients of the Fourier series if the fundamental frequency is 500 Hz.

## 6.13

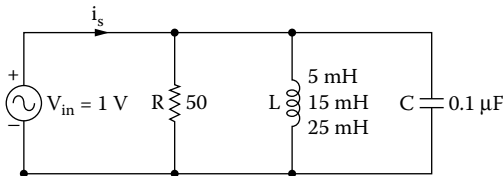
For Problem 6.9, calculate the coefficients of the Fourier series if the fundamental frequency is 500 Hz.

## 6.14

For Problem 6.10, calculate the coefficients of the Fourier series if the fundamental frequency is 500 Hz.

## 6.15

For the *RLC* circuit of [Figure P6.15](#), plot the frequency response of the current  $i_s$  through the circuit and the magnitude of the input impedance. The frequency of the source is varied from 100 Hz to 100 kHz with a decade increment and 10 points per decade. The values of the inductor  $L$  are 5, 15, and 25 mH.



**FIGURE P6.15** Parallel resonant RLC circuit.

**6.16**

Use PSpice to plot the frequency response of the output voltage in Problem 6.5 if the load resistance  $R_L$  is varied from 5 k $\Omega$  to 15 k $\Omega$  at an increment of 5 k $\Omega$ .

**6.17**

Use PSpice to find the worst-case minimum and maximum output voltages  $V_{o(\max)}$  and  $V_{o(\min)}$  for the circuit in Figure 6.15 of Example 6.3. Assume uniform tolerances of  $\pm 20\%$  for all resistances and an operating temperature of 25°C.

**6.18**

Use PSpice to find the worst-case minimum and maximum capacitor voltages  $V_{o(\max)}$  and  $V_{o(\min)}$  for the circuit in Figure 6.21 of Example 6.5. Assume uniform tolerances of  $\pm 20\%$  for all resistances,  $\pm 15\%$  for inductors,  $\pm 10\%$  for capacitors, and an operating temperature of 25°C.

**6.19**

Use PSpice to find the worst-case minimum and maximum output voltages  $V_{o(\max)}$  and  $V_{o(\min)}$  for the circuit in Figure 6.28 of Example 6.7. Assume uniform tolerances of  $\pm 20\%$  for all resistances and an operating temperature of 25°C.

---

# 7 Diode Rectifiers

The learning objectives of this chapter are:

- Modeling a diode in SPICE and specifying its model parameters
- Performing transient analysis of diode rectifiers
- Evaluating the performance of diode rectifiers
- Performing worst-case analysis of diode rectifiers for parametric variations of model parameters and tolerances

## 7.1 INTRODUCTION

A semiconductor diode may be modeled in SPICE by a diode statement in conjunction with a model statement. The diode statement specifies the diode name, the nodes to which the diode is connected, and its model name. The model incorporates an extensive range of diode characteristics such as DC and small-signal behavior, temperature dependency, and noise generation. The model parameters take into account temperature effects, various capacitances, and physical properties of semiconductors.

## 7.2 DIODE MODEL

The SPICE model for a reverse-biased diode is shown in [Figure 7.1](#) [1–3]. The small-signal and static models that are generated by SPICE are shown in [Figure 7.2](#) and [Figure 7.3](#), respectively. In the static model, the diode current, which depends on its voltage, is represented by a current source. The small-signal parameters are generated by SPICE from the operating point. SPICE generates a complex model for diodes. The model equations that are used by SPICE are described in Reference 1 and Reference 2. In many cases, especially the level at which this book is aimed, such complex models are not necessary. Many model parameters can be ignored by the users, and SPICE assigns default values to the parameters.

The model statement of a diode has the general form

```
.MODEL DNAME D(P1=V1 P2=V2 P3=V3 ... PN=VN)
```

DNAME is the model name, and it can begin with any character; but its word size is normally limited to eight. D is the type symbol for diodes. P1, P2, ... and V1, V2, ... are the model parameters and their values, respectively. The model parameters are listed in [Table 7.1](#). An area factor is used to determine the number of equivalent parallel diodes of the model specified. The model parameters that

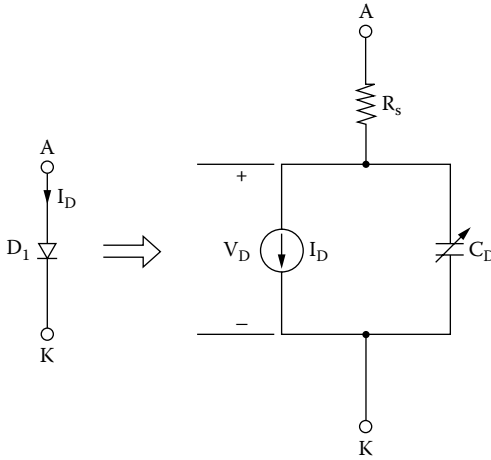


FIGURE 7.1 SPICE diode model with reverse-biased condition.

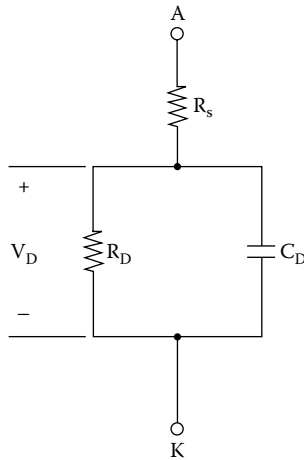


FIGURE 7.2 SPICE small-signal diode model.

are affected by the area factor are marked with an asterisk (\*) in the descriptions of the model parameters.

The diode is modeled as an ohmic resistance (value =  $RS/area$ ) in series with an intrinsic diode. The resistance is attached between node NA and an internal anode node.  $[area]$  value scales  $IS$ ,  $RS$ ,  $CJO$ , and  $IBV$ , and defaults to 1.  $IBV$  and  $BV$  are both specified as positive values.

The DC characteristic of a diode is determined by the reverse saturation current  $IS$ , the emission coefficient  $N$ , and the ohmic resistance  $RS$ . Reverse

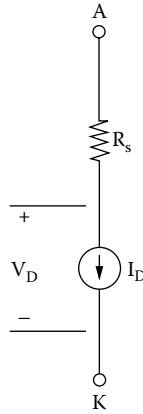


FIGURE 7.3 Static diode model with reverse-bias condition.

**TABLE 7.1**  
Parameters of Diode Model

Name	Area	Model parameter	Unit	Default	Typical
IS	*	Saturation current	A	1E-14	1E-14
RS	*	Parasitic resistance	W	0	10
N		Emission coefficient	1	1	
TT		Transit time	sec	0	0.1NS
CJO	*	Zero-bias <i>p-n</i> capacitance	F	0	2PF
VJ		Junction potential	V	1	0.6
M		Junction grading coefficient		0.5	0.5
EG		Activation energy	eV	1.11	11.1
XTI		IS temperature exponent		3	3
KF		Flicker noise coefficient		0	
AF		Flicker noise exponent		1	
FC		Forward-bias depletion capacitance coefficient		0.5	
BV		Reverse breakdown voltage	V	•	50
IBV	*	Reverse breakdown current	A	1E-10	

breakdown is modeled by an exponential increase in the reverse diode current and is determined by the reverse breakdown voltage BV, and the current at breakdown voltage IBV. The charge storage effects are modeled by the transit time TT and a nonlinear depletion layer capacitance, which depends on the zero-bias junction capacitance CJO, the junction potential VJ, and grading coefficient M.

The temperature of the reverse saturation current is defined by the gap activation energy (or gap energy) EG and the saturation temperature exponent XTI. The most important parameters for power electronics applications are IS, BV, IBV, TT, and CJO.

### 7.3 DIODE STATEMENT

The name of a diode must start with D, and it takes the general form

```
D<name> NA NK DNAME[(area) value]
```

where NA and NK are the node the cathode nodes, respectively. The current flows from anode node NA through the diode to cathode node NK. DNAME is the model name.

Some diode statements are

```
D15 33 35 SWITCH 1.5
```

```
.MODEL SWITCH D(IS=100E-15 CJO=2PF TT=12NS BV=100
IBV=10E-3)
```

```
DCLAMP 0 8 DIN914
```

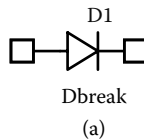
```
.MODEL DIN914 D (IS=100E-15 CJO=2PF TT=12NS BV=100
IBV=10E-3)
```

The PSpice schematic of a diode with a model name Dbreak is shown in Figure 7.4(a). The EVAL library of the PSpice student version supports few low-power diodes such as D1N4002, D1N4148, and D1N914. However, the user can change the model parameters of a Dbreak device. Click the right mouse button to open the window Edit PSpice Model as shown in Figure 7.4(b). The model name can also be changed. The breakout devices are available from the BREAKOUT Library.

### 7.4 DIODE CHARACTERISTICS

The typical  $V-I$  characteristic of a diode is shown in Figure 7.5. The characteristic can be expressed by an equation known as the *Schockley diode equation*, given by

$$I_D = I_s (e^{V_D/nV_T} - 1) \quad (7.1)$$



Models List		
Model Name	Type	Cr
Dbreak*	Diode	

```
.model Dbreak D Is=1e-14 Cjo=.1pF Rs=.1
```

(b)

**FIGURE 7.4** Diode symbol and model parameters. (a) Symbol, (b) parameters of Dbreak model.

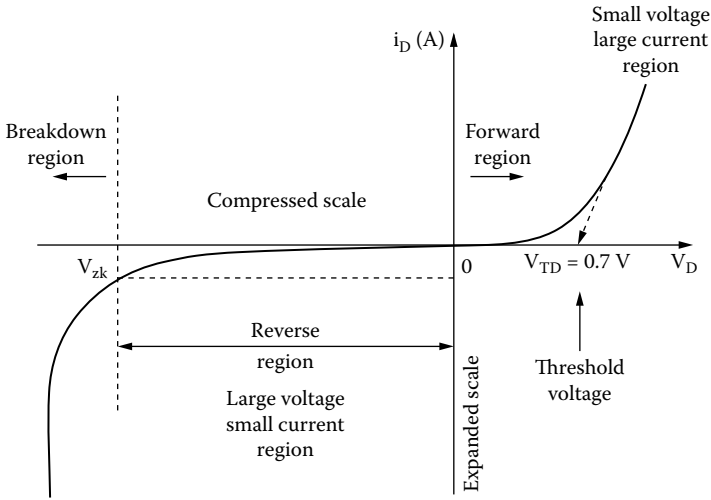


FIGURE 7.5 Diode characteristics.

where

$I_D$  = current through the diode, A

$V_D$  = diode voltage with anode positive with respect to cathode, V

$I_s$  = leakage (or reverse saturation) current, typically in the range  $10^{-6}$  to  $10^{-20}$  A

$n$  = Empirical constant known as the *emission coefficient* (or *ideality factor*), whose value varies from 1 to 2

The emission coefficient,  $n$ , depends on the material and the physical construction of diodes. For germanium diodes,  $n$  is considered to be 1. For silicon diodes, the predicted value of  $n$  is 2, but for most silicon diodes the value of  $n$  is in the range 1.1 to 1.8.

$V_T$  in Equation 7.1 is a constant called the *thermal voltage*, and it is given by

$$V_T = \frac{kT}{q} \tag{7.2}$$

where

$q$  = electron charge:  $1.6022 \times 10^{-19}$  C

$T$  = Absolute temperature, kelvin ( $K = 273 + ^\circ C$ )

$k$  = Boltzmann’s constant:  $1.3806 \times 10^{-23}$  J/K

At a junction temperature of  $25^\circ C$ , Equation 7.2 gives

$$V_T = \frac{kT}{q} = \frac{1.3806 \times 10^{-23} \times (273 + 25)}{1.6022 \times 10^{-19}} \approx 25.8 \text{ mV}$$

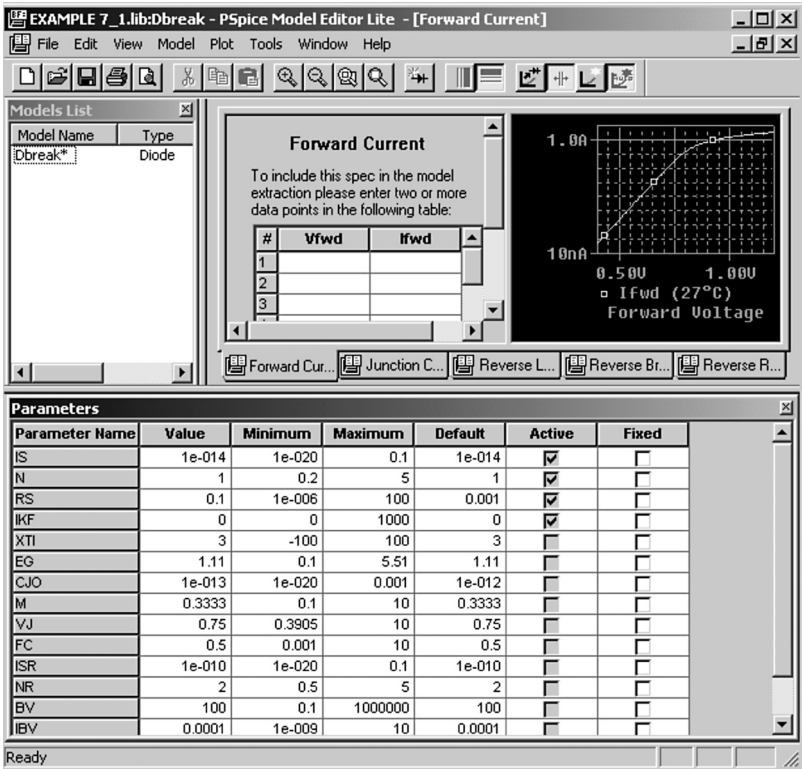


FIGURE 7.6 PSpice Model Editor.

At a specified temperature, the leakage current  $I_s$  remains constant for a given diode. For power diodes, the typical value of  $I_s$  is  $10^{-15}$  A.

The plots of the diode characteristics can be viewed from the View menu of the PSpice Model Editor as shown in Figure 7.6. These include forward current ( $V_{fwd}$  vs.  $I_{fwd}$ ), junction capacitance ( $V_{rev}$  vs.  $C_j$ ), reverse leakage ( $V_{rev}$  vs.  $I_{rev}$ ), reverse breakdown ( $V_z$ ,  $I_z$ ,  $Z_z$ ), and reverse recovery ( $T_{rr}$ ,  $I_{fwd}$ ,  $I_{rev}$ ).

## 7.5 DIODE PARAMETERS

The data sheet for IR diodes of type RI8 is shown in Figure 7.7. Although PSpice allows specifying many parameters, we use only the parameters that significantly affect power converter output. From the data sheet, we have

Reverse breakdown voltage,  $BV = 1200$

Reverse breakdown current,  $IBV = 13$  mA

Instantaneous voltage,  $v_F = 1$  V at  $i_F = 150$  A

Reverse recovery charge,  $Q_{RR} = 194$   $\mu$ C at  $I_{FM} = 200$  A

R18C, R18S, R18CR & R18SR SERIES  
 1800–1200 VOLTS RANGE  
 185 AMP AVG STUD MOUNTED  
 DIFFUSED JUNCTION RECTIFIER DIODES

**VOLTAGE RATINGS**

VOLTAGE CODE (1)	$V_{RRM}$ Max. rep. peak reverse and direct voltage	$V_R - (V)$	$V_{RSH} - (V)$ Max. non-rep. peak reverse voltage
	$T_j = 0^\circ$ to $200^\circ\text{C}$	$T_j = -40^\circ$ to $0^\circ\text{C}$	$T_j = 25^\circ$ to $200^\circ\text{C}$
18A	1800	1710	1900
16A	1600	1520	1700
14B	1400	1330	1500
12B	1200	1200	1300

**MAXIMUM ALLOWABLE RATINGS**

PARAMETER	SERIES (2)	VALUE	UNITS	NOTES
$T_j$ Junction temperature	ALL	-40 to 200	$^\circ\text{C}$	
$T_{stg}$ Storage temperature	ALL	-40 to 200	$^\circ\text{C}$	
$I_{F(AV)}$ Average current	R18C/S	185	A	180° half sine wave, $T_C = 140^\circ\text{C}$
$I_{F(AV)}$ Max. av. current (3)	ALL	200	A	180° half sine wave, $T_C = 133^\circ\text{C}$ , 18C/S $T_C = 145^\circ\text{C}$ , R18CR/SR
$I_{F(RMS)}$ Max. RMS current (3)	ALL	314	A	
$I_{FSH}$ Max. peak non-rep. surge current	ALL	3820	A	50 Hz half cycle sine wave Initial $T_j = 200^\circ\text{C}$ , rated 60 Hz half cycle sine wave $V_{RPM}$ applied after surge.
		4000		
		4550		
		4750		
$I^2_t$ Max. $I^2_t$ capability	ALL	73	$\text{kA}^2\text{s}$	$t = 10$ ms Initial $T_j = 200^\circ\text{C}$ , rated $V_{RPM}$ applied $t = 8.3$ ms after surge.
		67		
		104		
		95		
$I^2_{\sqrt{t}}$ Max. $I^2_{\sqrt{t}}$ capability	ALL	1040	$\text{kA}^2\sqrt{\text{s}}$	Initial $T_j = 200^\circ\text{C}$ , no voltage applied after surge. $I^2_t$ for time $t_x = I^2_{\sqrt{t}} \cdot \sqrt{t_x} \cdot \sqrt{t_x} \cdot 0.1 \leq t_x \leq 10$ ms.
T Mounting torque	R18C/CR	14.1 (125)	$\text{N}\cdot\text{m}$ (lbf-in)	Non-lubricated threads
		17.0 (150)		Lubricated threads
		12.2 (108)		
		15.0 (132)		
	R18S/SR	11.3 (100)	$\text{N}\cdot\text{m}$ (lbf-in)	
		14.1 (125)		Lubricated threads
		9.5 (85)		
		12.5 (110)		

- (1) To complete the part number, refer to the [Ordering Information table](#).
- (2) R18C & R18S series have cathode-to-case polarity; R18CR & R18SR series have anode-to-case polarity.
- (3) For devices assembled in Europe, max.  $I_{F(AV)}$  is 175 A and max.  $I_{F(RMS)}$  is 275 A.

**FIGURE 7.7** Data sheets for IR diodes of type R18. (Courtesy of International Rectifier.)

From the data for the  $V-I$  forward characteristic of a diode, it is possible to determine the value of  $n$ ,  $V_T$  and  $I_s$  of the diode [4]. Assuming that  $n = 1$  and  $V_T = 25.8$  mV, we can apply Equation 7.1 to find the saturation current  $I_s$ :

**CHARACTERISTICS**

PARAMETER	SERIES	MIN.	TYP.	MAX.	UNITS	TEST CONDITIONS
V <sub>FM</sub> Peak forward voltage	ALL	—	1.30	1.42	V	Initial T <sub>j</sub> = 25°C, 50–80 Hz half sine, I <sub>peak</sub> = 628 A.
V <sub>F(TO)1</sub> Low-level threshold	ALL	—	—	0.703	V	T <sub>j</sub> = 200°C Av. power = V <sub>F(TO)</sub> * I <sub>F(AV)</sub> + r <sub>F</sub> * (I <sub>F(RMS)</sub> ) <sup>2</sup> Use low level values for I <sub>FM</sub> ≤ πI <sub>F(AV)</sub>
V <sub>F(TO)2</sub> High-level threshold		—	—	0.738		
r <sub>F1</sub> Low-level resistance	ALL	—	—	1.100	πΩ	
r <sub>F2</sub> High-level resistance		—	—	1.080		
t <sub>a</sub> Reverse current rise	ALL	—	18.0	—	μs	
t <sub>b</sub> Reverse current fall	ALL	—	3.5	—	μs	
I <sub>RM(REC)</sub> Reverse current	ALL	—	18	—	A	
Q <sub>RR</sub> Recovered charge	ALL	—	194	—	μc	
I <sub>RM</sub> Peak reverse current	ALL	—	13	20	mA	
R <sub>thJC</sub> Thermal resistance, junction-to-case	R18C/S	—	—	0.250	°C/W	DC operation
	R18CR/SR	—	—	0.200	°C/W	180° sine wave
	R18C/S	—	—	0.271		
	R18CR/SR	—	—	0.221		
	R18C/S	—	—	0.275	°C/W	120° rectangular wave
R18CR/SR	—	—	0.225	°C/W		
R <sub>thCS</sub> Thermal resistance, case-to-sink	ALL	—	—	0.10	°C/W	Mtg. surface smooth, flat and greased.
wt Weight	ALL	—	110(3.5)	—	g(oz.)	
Case style	R18C/CR	DO-205AC (DO-30)			JEDEC	
	R18S/SR	DO-205AA (DO-8)				

**FIGURE 7.7** (continued).

$$I_D = I_s (e^{V_D/nV_T} - 1)$$

$$150 = I_s (e^{1/(25.8 \times 10^{-3})} - 1)$$

which gives  $I_s = 2.2 \text{ E} - 15 \text{ A}$ .

Let us call the diode model name DMOD. The values of TT and CJO are not available from the data sheet. Some versions of SPICE (e.g., PSpice) support device library files. The software PARTS of PSpice can generate SPICE models from the data sheet parameters of transistors and diodes. The transit time  $\tau_T$  can be calculated approximated from

$$\tau_T = \frac{Q_{RR}}{I_{FM}} = \frac{194 \mu\text{C}}{200} \approx 1 \mu\text{s}$$

We shall assume the typical value CJO = 2PF. Thus, the PSpice model statement is

```
.MODEL DMODD (IS=2.22E-15 BV=1200 IBV=13E-3 CJO=2PF
TT=1US)
```

**R18C, R18S, R18CR & R18SR SERIES**  
**1800 – 1200 VOLTS RANGE**

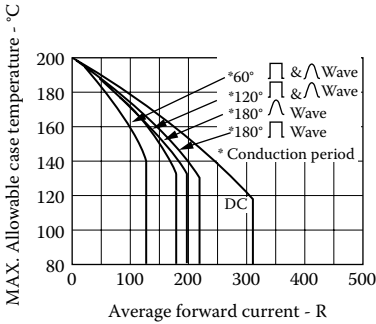


Fig. 1 – Case temperature ratings – R18C and R18S series

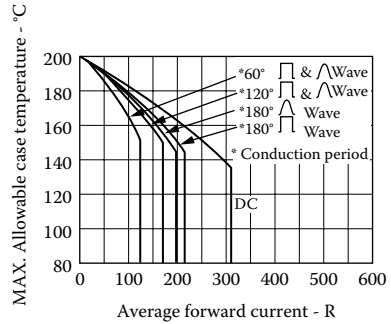


Fig. 1a – Case temperature ratings – R18CR and R18SR series

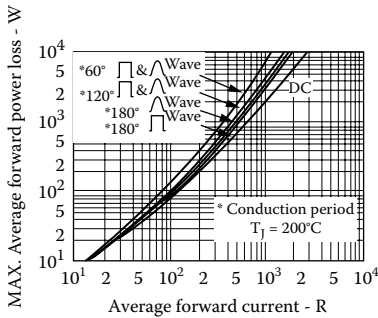


Fig. 2 – Power loss characteristics – R18C, R18S, R18CR and R18SR series

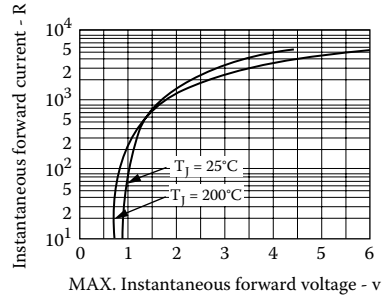


Fig. 3 – Forward characteristics – R18C, R18S, R18CR and R18SR series

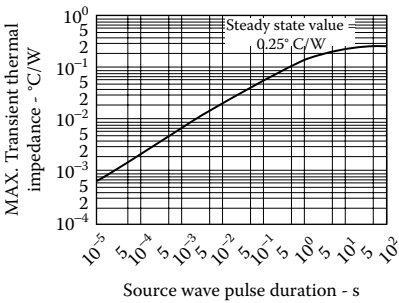


Fig. 4 – Transient thermal impedance junction-to-case – R18C and R18S series

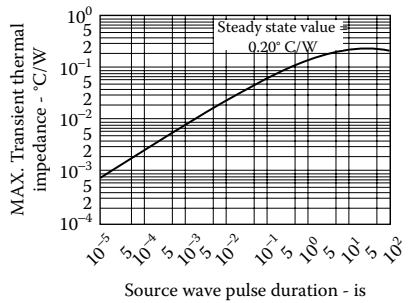


Fig. 4a – Transient thermal impedance junction-to-case – R18CR and R18SR series

**FIGURE 7.7** (continued).

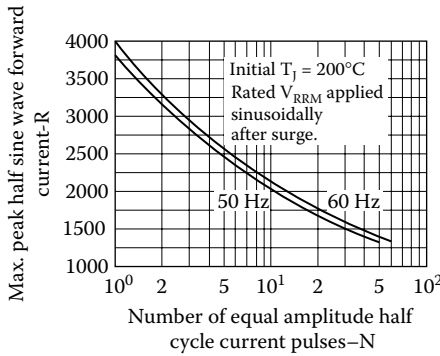


Fig. 5–Non-Repetitive Surge Current Ratings–R18C, R18S, R18CR and R18SR series

**Ordering information**

Type	Package (1)		Polarity		Voltage	
	Code	Description	Code	Description	Code	V <sub>RRM</sub>
R18	C	1/2" stud, ceramic housing (Fig. 1)	—	Cathode-to-case	18A	1800 V
			R	Anode-to-case	18A	1600 V
	S	3/8" stud, ceramic housing (Fig. 2)			14B	1400 V
					12B	1200 V

- (1) Other packages are also available:
- stud base with flag terminal.
  - stud base with threaded top terminal.
  - flat base.

For further details contact factory.

For example, for a device with 1/2" stud base and flexible lead, reverse polarity, V<sub>RRM</sub> = 1600 V, order as: R18CR16A.

FIGURE 7.7 (continued).

**7.5.1 MODELING ZENER DIODES**

To model a Zener diode, the breakdown voltage parameter BV in the model statement is set to the Zener voltage V<sub>z</sub>. That is, BV = VZ. For a zener diode of 220 V, the diode model statement is

```
.MODEL DMOD D(IS = 2.22E-15 BV = 220V IBV = 12E-2 CJO = 2PF TT = 1US)
```

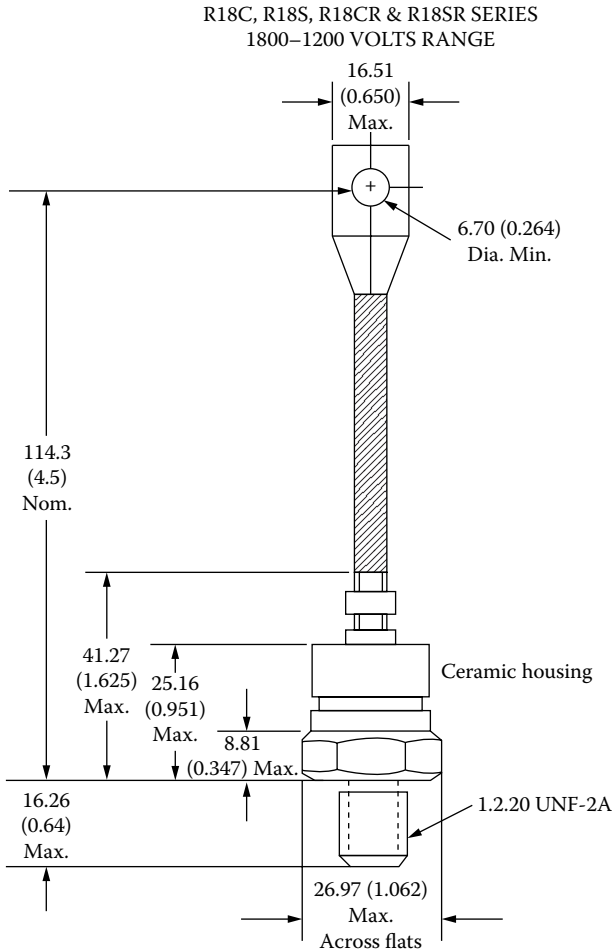


FIGURE 7.7 (continued).

### 7.5.2 TABULAR DATA

The manufacturer generally supplies the  $I$ - $V$  characteristic of a diode as shown in Figure 3 of Figure 7.7. This characteristic can be represented in a tabular form as shown in Table 7.2. This table can represent a current-controlled voltage source (see Subsection 4.5.2).

#### EXAMPLE 7.1 DESCRIBING THE DIODE CHARACTERISTIC OF TABULAR DATA

The diode circuit shown in Figure 7.8(a) has  $V_{DC} = 220 \text{ V}$  and  $R_L = 0.5 \Omega$ . Use PSpice to calculate the diode current and the diode voltage. Use the diode characteristics in Table 7.2.

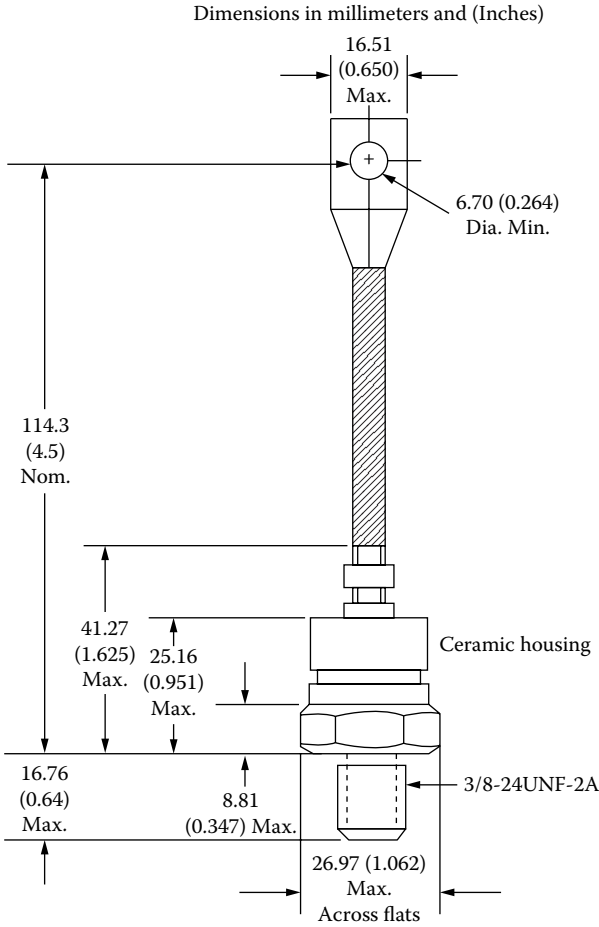


FIGURE 7.7 (continued).

**TABLE 7.2**  
**Typical  $I-V$  Data of a Power Diode**

$I_D$ (A)	0	20	40	100	500	800	1000	1600	2000	3000	3900
$V_D$ (V)	0	0.8	0.9	1.0	1.26	1.5	1.7	2.0	2.3	3	3.5

**SOLUTION**

The diode is modeled as a current-controlled voltage source as shown in [Figure 7.8\(b\)](#) to represent the table of the  $I-V$  characteristic. The PSpice schematic is shown

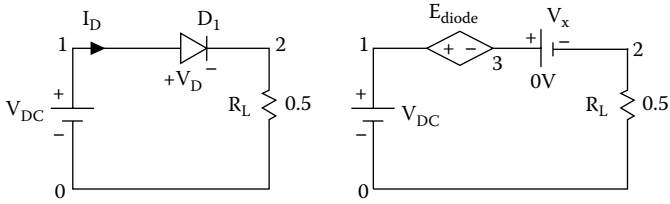
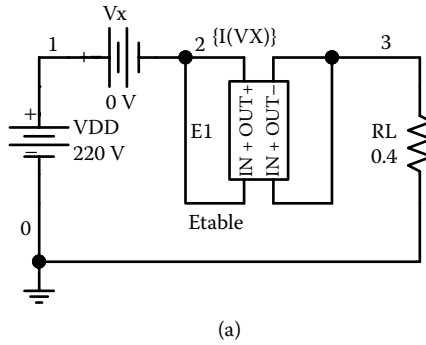


FIGURE 7.8 Diode circuit. (a) Diode circuit, (b) PSpice circuit.



(a)

Value	EXPR	TABLE
ETABLE	{I(VX)}	(0, 0) (20, 0.8) (40, 0.9) (100, 1.0) (500, 1.26) (800, 1.5) (1000, 1.7) (1600, 2.0) (2000, 2.3) (3000, 3) (3900, 3.5)

(b)

FIGURE 7.9 PSpice schematic for Example 7.1. (a) ETABLE, (b) ETABLE parameters.

in Figure 7.9(a). The diode is modeled by an ETABLE from the abm.slb library. The current is related to the voltage in table form as shown in Figure 7.9(b).

The listing of the circuit file follows:

**Example 7.1 Diode circuit**

```
VDD 1 0 DC 220V ; DC voltage of 15 V
VX 3 2 DC 0V ; measures the diode current ID
RL 2 0 0.4
* The diode is represented by a table
Ediode 1 3 TABLE { I(VX) } =
+ (0, 0) (20, 0.8) (40, 0.9) (100, 1.0) (500, 1.26) (800, 1.5)
+ (1000, 1.7) (1600, 2.0) (2000, 2.3) (3000, 3) (3900, 3.5)
.OP ; Prints the details of operating point
.END ; End of circuit file
```

The information about the operating point, which is obtained from the output file EX7. 1.OUT, is follows:

```
**** OPERATING POINT INFORMATION  TEMPERATURE = 27.000 DEG C
NAME          Ediode
V-SOURCE      1.297E+00      (VD = 1.297 V)
I-SOURCE      5.468E+02      (ID = 546.8 A)
```

*Note:* The diode current is listed in terms of (i, v) data points.

## 7.6 DIODE RECTIFIERS

A rectifier converts an AC voltage to a DC voltage and uses diodes as the switching devices. The output voltage of an ideal rectifier should be pure DC and contain no harmonics or ripples. Similarly, the input current should be pure sine wave and contain no harmonics. That is, the total harmonic distortion (THD) of the input current and output voltage should be zero, and the input power factor should be unity.

The output voltage, the output current, and the input current of a rectifier contain harmonics. The input power factor  $PF_i$  can be determined from the  $THD_i$  of the input current as follows:

$$PF_i = \frac{I_{1(\text{rms})}}{I_s} \cos \phi_1 = \frac{1}{\sqrt{1 + \left(\frac{\%THD}{100}\right)^2}} \cos \phi_1 \quad (7.3)$$

where

$I_{1(\text{rms})}$  = rms value of the fundamental input current

$I_s$  = rms value of the input current

$\phi_1$  = angle between the fundamental component of the input current and the fundamental component of the input voltage

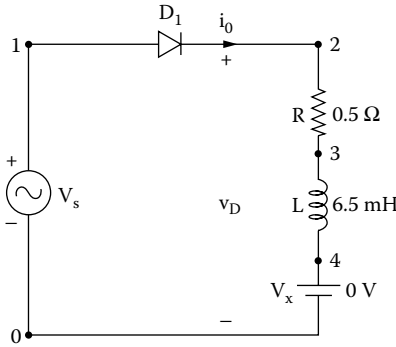
$\%THD$  = percentage total harmonic distortion of the input current

### EXAMPLE 7.2 FINDING THE PERFORMANCE OF A HALF-WAVE DIODE RECTIFIER

A single-phase half-wave rectifier is shown in [Figure 7.10](#). The input voltage is sinusoidal with a peak of 169.7 V, 60 Hz. The load inductance  $L$  is 6.5 mH, and the load resistance  $R$  is 0.5  $\Omega$ . Use PSpice (a) to plot the instantaneous output voltage  $v_o$ , and the load current  $i_o$ , (b) to calculate the Fourier coefficient of the output voltage, and (c) to find the input power factor.

#### SOLUTION

$f = 60$  Hz and  $V_m = 169.7$  V.



**FIGURE 7.10** Single-phase half-wave rectifier for PSpice simulation.

The PSpice schematic is shown in [Figure 7.11\(a\)](#). The parameters of a Dbreak diode with model DMOD are shown in [Figure 7.11\(b\)](#). The transient setup is shown in [Figure 7.11\(c\)](#) and that for the Fourier analysis is shown in [Figure 7.11\(d\)](#).

The listing of the circuit file is as follows:

---

**Example 7.2 Single-phase half-wave rectifier with RL load**

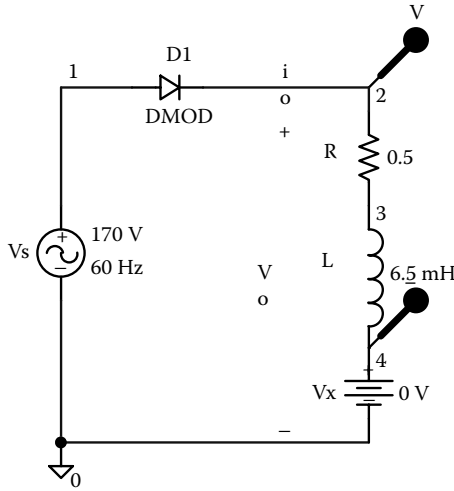
```

SOURCE   ■ VS 1 0 SIN (0 169.7V 60HZ)
CIRCUIT  ■■ R 2 3 0.5
            L 3 4 6.5MH
            VX 4 0 DC 0V ;Voltage source to measure the output
            current
            D1 1 2 DMOD
            .MODEL DMOD D(IS=2.22E-15 BV=1200V IBV=13E-
            3 CJO=2PF TT=1US)
ANALYSIS ■■■ .TRAN 10US 50.0MS 16.6667MS 10US ; Transient analysis
                .FOUR 60HZ I(D1) V(2)          ; Fourier analysis of input
                current and output voltage
            *
            .PROBE                               ; Graphics post-processor
            .OPTIONS ABSTOL = 1.0N RELTOL = .01 VNTOL = 1.0M
            ITL5 = 10000;
            *
                Convergence
    .END
    
```

---

Note the following:

- (a) The PSpice plots of the instantaneous output voltage  $V(2)$  and load current  $I(VX)$  are shown in [Figure 7.12](#). The output voltage becomes negative due to the inductive load, because the current has to fall to zero before the diode can cease to conduct.



(a)

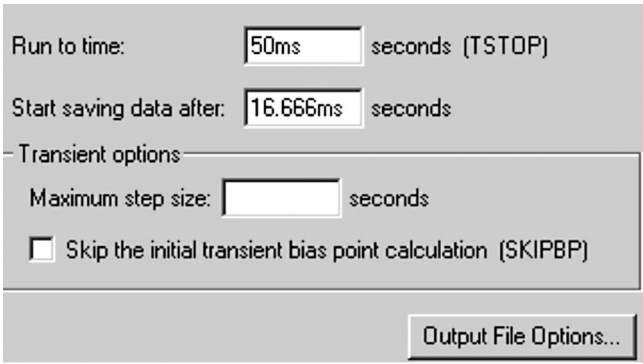
```
.MODEL DMOD D(IS=2.22E-15 BV=1200V IBV=12E-2 CJO=2PF TT=1US)
```

(b)

Run to time:	<input type="text" value="50ms"/>	seconds (TSTOP)
Start saving data after:	<input type="text" value="16.666ms"/>	seconds
- Transient options -		
Maximum step size:	<input type="text"/>	seconds
<input type="checkbox"/> Skip the initial transient bias point calculation (SKIPBPP)		
<input type="button" value="Output File Options..."/>		

(c)

**FIGURE 7.11** PSpice schematic for Example 7.2. (a) Schematic, (b) diode model parameters, (c) transient setup, (d) Fourier setup.



(d)

FIGURE 7.11 (continued).

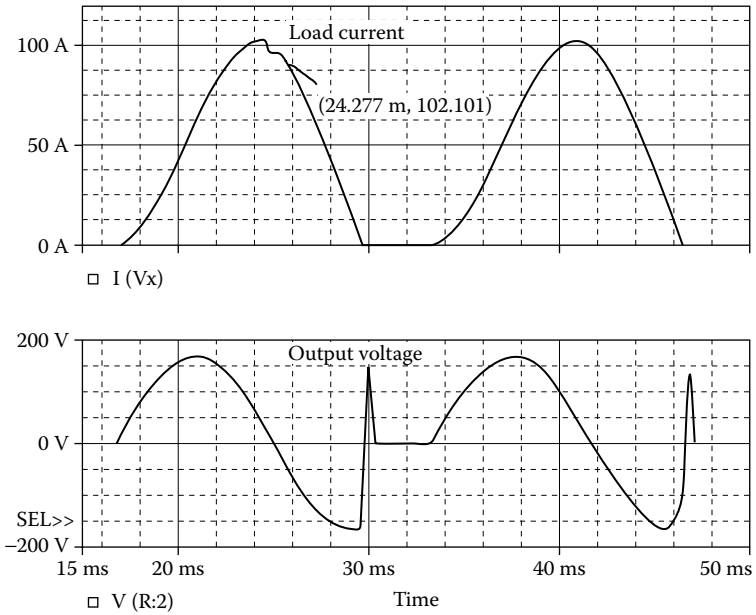


FIGURE 7.12 Plots for Example 7.2.

- (b) Fourier coefficients and THD will depend slightly on the internal time step TMAX discussed in Subsection 6.9.2.

---

### THE FOURIER COMPONENTS OF TRANSIENT RESPONSE V (2)

DC COMPONENT = 2.218909E+01

Harmonic No	Frequency (Hz)	Fourier Component	Normalized Component	Phase (Deg)	Normalized Phase (Deg)
1	6.000E+01	1.377E+02	1.000E+00	1.119E+01	0.000E+00
2	1.200E+02	3.646E+01	2.647E-01	-1.642E+02	-1.754E+02
3	1.800E+02	2.651E+01	1.925E-01	-1.076E+02	-1.188E+02
4	2.400E+02	1.649E+01	1.197E-01	-4.324E+01	-5.442E+01
5	3.000E+02	9.585E+00	6.958E-02	3.968E+01	2.849E+01
6	3.600E+02	8.108E+00	5.887E-02	1.366E+02	1.254E+02
7	4.200E+02	8.486E+00	6.161E-02	-1.431E+02	-1.542E+02
8	4.800E+02	7.607E+00	5.523E-02	-7.090E+01	-8.209E+01
9	5.400E+02	5.897E+00	4.281E-02	6.598E+00	-4.591E+00

TOTAL HARMONIC DISTORTION = 3.720415E+01 PERCENT

---

- (c) To find the input power factor, we need to find the Fourier series of the input current, which is the same as the current through diode  $D_1$ .

---

### THE FOURIER COMPONENTS OF TRANSIENT RESPONSE I (D1)

DC COMPONENT = 4.438586E+01

Harmonic No	Frequency (Hz)	Fourier Component	Normalized Component	Phase (Deg)	Normalized Phase (Deg)
1	6.000E+01	5.507E+01	1.000E+00	-6.738E+01	0.000E+00
2	1.200E+02	7.448E+00	1.352E-01	1.107E-02	1.781E+02
3	1.800E+02	3.634E+00	6.598E-02	1.681E+02	2.355E+02
4	2.400E+02	1.606E+00	2.916E-02	-1.317E+02	-6.432E+01
5	3.000E+02	8.217E-01	1.492E-02	-5.059E+01	1.678E+01
6	3.600E+02	5.774E-01	1.048E-02	5.326E+01	1.206E+02
7	4.200E+02	4.422E-01	8.030E-03	1.264E+02	1.938E+02
8	4.800E+02	4.177E-01	7.584E-03	-1.633E+02	-9.597E+01
9	5.400E+02	2.892E-01	5.251E-03	-7.644E+01	-9.061E+00

TOTAL HARMONIC DISTORTION = 1.548379E+01 PERCENT

---

DC input current  $I_{in(DC)} = 44.39$  A

Rms fundamental input current,  $I_{1(rms)} = 55.07/\sqrt{2} = 38.94$  A

THD of input current  $THD = 15.48\% = 0.1548$

Harmonic input current,  $I_{h(rms)} = I_{1(rms)} \times THD = 38.94 \times 0.1548 = 6.028$  A

Rms input current  $I_s = [I_{in(dc)}^2 + I_{r(rms)}^2 + I_{h(rms)}^2]^{1/2}$   
 $= (44.39^2 + 38.94^2 + 6.028^2)^{1/2} = 59.36$  A

Displacement angle  $\phi_1 = -64.38^\circ$

Displacement factor  $DF = \cos \phi_1 = \cos(-67.38) = 0.3846$ (lagging)

Thus, the input power factor is given [1] by

$$PF = \frac{I_{1(ms)}}{I_s} \cos \phi_1 = \frac{38.94}{59.36} \times 0.3846 = 0.2523 \text{ (lagging)}$$

The power factor can be determined directly from the THD as follows:

$$PF = \frac{I_{1(ms)}}{I_s} \cos \phi_1 = \frac{1}{[1 + (\%THD / 100)^2]^{1/2}} \cos \phi_1 \tag{7.4}$$

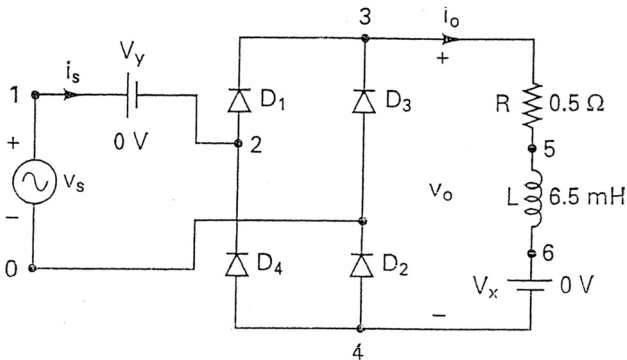
$$= \frac{1}{(1 + 0.1548^2)^{1/2}} \times 0.3846 = 0.3801 \text{ (lagging)}$$

This gives a higher value and cannot be applied if there is a significant amount of DC component.

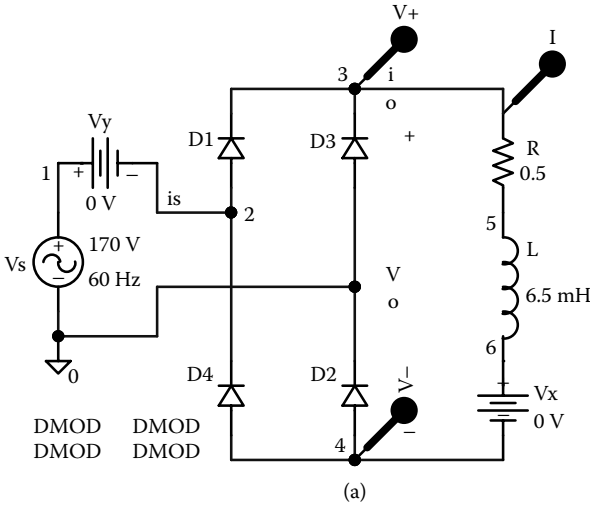
*Note:* The load current is discontinuous. When the diode turns off, there is a voltage transient. If an antiparallel diode (also known as the freewheeling diode) is connected across the load (terminals 2 and 0), the load current will be smoother. As a result, the power factor will improve. Students are encouraged to simulate the circuit with an antiparallel diode to verify this.

**EXAMPLE 7.3 FINDING THE PERFORMANCE OF A SINGLE-PHASE BRIDGE RECTIFIER**

A single-phase bridge rectifier is shown in Figure 7.13. The sinusoidal input voltage has a peak of 169.7 V, 60 Hz. The load inductance  $L$  is 6.5 mH, and the load resistance  $R$  is 0.5  $\Omega$ . Use PSpice (a) to plot the instantaneous output voltage  $v_o$  and the load current  $i_o$  and (b) to calculate the Fourier coefficients of the input current and the input power factor.



**FIGURE 7.13** Single-phase bridge rectifier.



Run to time:  seconds (TSTOP)

Start saving data after:  seconds

Transient options:

Maximum step size:  seconds

Skip the initial transient bias point calculation (SKIPBP)

© Transient setup

Print values in the output file every:  seconds

Perform Fourier Analysis

Center Frequency:  hz

Number of Harmonics:

Output Variables:

Include detailed bias point information for nonlinear controlled sources and semiconductors (/OP)

© Fourier setup

(b)

FIGURE 7.14 PSpice schematic for Example 7.3. (a) Schematic, (b) transient setup, (c) Fourier setup.

**SOLUTION**

$V_m = 169.7 \text{ V}$  and  $f = 60 \text{ Hz}$ . The PSpice schematic is shown in Figure 7.14(a). The transient setup is shown in Figure 7.14(b) and that for the Fourier analysis of the input current is shown in Figure 7.14(c). The listing of the circuit file is as follows:

**Example 7.3 Single-phase bridge rectifier with RL load**

```

SOURCE  ■ VS 1 0 SIN (0169.7V60HZ)
CIRCUIT ■■ R 3 5 0.5
          L 5 6 6.5MH
          VX 6 4 DC 0V ; Voltage source to measure the output
          current
          VY 1 2 DC 0V ; Voltage source to measure the output
          current
    
```

```
D1 2 3 DMOD
D3 0 3 DMOD
D2 4 0 DMOD
D4 4 2 DMOD
.MODEL DMOD D(IS=2.22E-15 BV=1200V IBV=13E-
3 CJO=2PF TT=1US)
```

```
ANALYSIS TRAN 10US 50MS 33.3333MS 10US ; Transient analysis
.FOUR 60HZ 1(VY) ; Fourier analysis of
* input current
.PROBE ; Graphic POST-
post-processor
.OPTIONS ABSTOL = 1.0 N RELTOL = .01 BNTOL = 1.0M
ITL5=10000 ;
* Convergence
.END
```

Note the following:

- (a) The PSpice plots of the instantaneous output voltage V(3, 4) and load current I(VX) are shown in [Figure 7.15](#). One of the diode pairs always conducts. The load current contains ripples and has not reached steady-state conditions.
- (b) The input current, which is the same as the current through the voltage source VY, is equal to I(VY).

### THE FOURIER COMPONENTS OF TRANSIENT RESPONSE I(VY)

DC COMPONENT = -2.56451E + 00

Harmonic No	Frequency (Hz)	Fourier Component	Normalized Component	Phase (Deg)	Normalized Phase(Deg)
1	6.000E + 01	2.595E+02	1.000E+00	-3.224E+00	0.000E+00
2	1.200E + 02	7.374E-01	2.842E-03	1.410E+02	1.442E+02
3	1.800E + 02	8.517E+01	3.282E-01	4.468E+00	7.693E+00
4	2.400E + 02	5.856E-01	2.257E-03	1.199E+02	1.232E+02
5	3.000E + 02	5.118E+01	1.972E-01	3.216E+00	6.440E+00
6	3.600E + 02	5.526E-01	2.130E-03	1.111E+02	1.143E+02
7	4.200E + 02	3.658E+01	1.410E-01	2.868E+00	6.092E+00
8	4.800E + 02	5.406E-01	2.083E-03	1.065E+02	1.097E+02
9	5.400E + 02	2.846E+01	1.097E-01	2.822E+00	6.047E+00

TOTAL HARMONIC DISTORTION = 4.225668E + 01 PERCENT

DC input current  $I_{in(DC)} = -2.56$  A, which should ideally be zero

Rms fundamental input current  $I_{1(rms)} = 259.5/\sqrt{2} = 183.49$  A

THD of input current  $THD = 42.26\% = 0.4226$

Rms harmonic current  $I_{h(rms)} = I_{1(rms)} \times THD = 183.49 \times 0.4226 = 77.54$  A

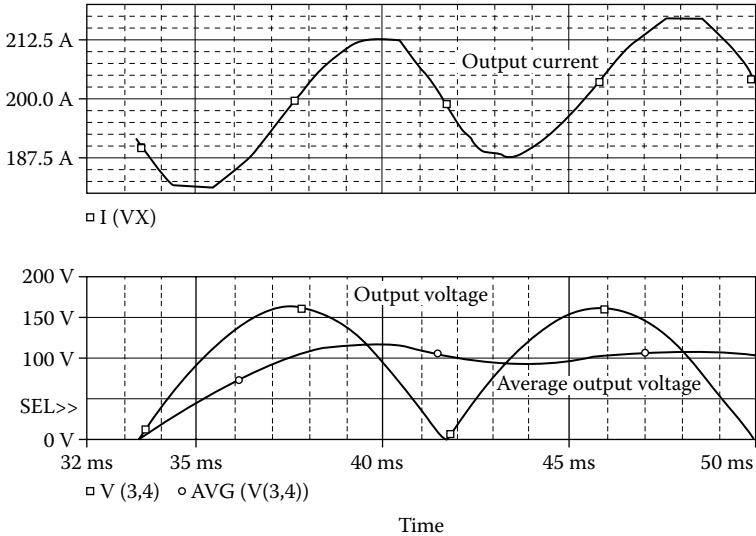


FIGURE 7.15 Plots for Example 7.3.

$$\begin{aligned} \text{Rms input current } I_s &= (I_{\text{in(DC)}}^2 + I_{1(\text{rms})}^2 + I_{h(\text{rms})}^2)^{1/2} \\ &= (2.56^2 + 183.49^2 + 77.54^2)^{1/2} = 199.22 \text{ A} \end{aligned}$$

$$\text{Displacement angle } \phi_1 = -3.22$$

$$\text{Displacement factor } DF = \cos \phi_1 = \cos(-3.22) = 0.998 \text{ (lagging)}$$

Thus, the input power factor is

$$\text{PF} = \frac{I_{1(\text{rms})}}{I_s} \cos \phi_1 = \frac{183.49}{199.22} \times 0.998 = 0.9192 \text{ (lagging)}$$

Assuming that  $I_{\text{in(DC)}} = 0$ , Equation 7.3 gives the power factor as

$$\text{PF} = \frac{1}{(1 + 0.4226^2)^{1/2}} \times 0.9981 = 0.9193 \text{ (lagging)}$$

*Note:* The load current is continuous. The input power factor (0.919) is much higher compared to that (0.3802) of the half-wave rectifier.

#### EXAMPLE 7.4 FINDING THE PERFORMANCE OF A SINGLE-PHASE BRIDGE RECTIFIER

A single-phase bridge rectifier with an  $LC$  filter is shown in Figure 7.16. The sinusoidal input voltage has a peak of 169.7 V, 60 Hz. The load inductance  $L$  is 10 mH, and the load resistance  $R$  is 40  $\Omega$ . The filter inductance  $L_c$  is 30.83 mH, and filter capacitance  $C_c$  is 326  $\mu\text{F}$ . Use PSpice (a) to plot the instantaneous output

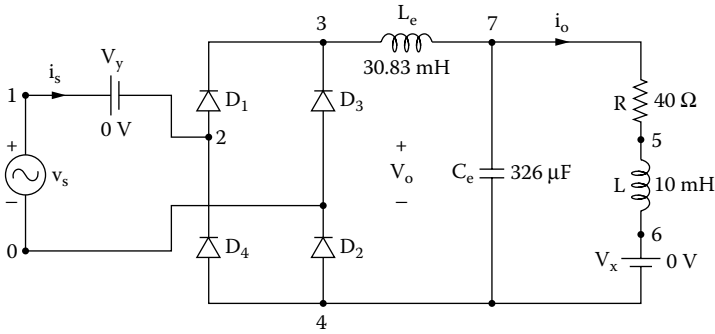


FIGURE 7.16 Single-phase bridge rectifier with load filter.

voltage  $v_o$  and the load current  $i_o$ , (b) to calculate the Fourier coefficients of the output voltage, (c) to calculate the Fourier coefficients of the input current and input power factor, and (d) plot the instantaneous output voltage for  $C_e = 1 \mu F$ ,  $100 \mu F$ , and  $326 \mu F$ .

**SOLUTION**

The PSpice schematic is shown in Figure 7.17(a). The capacitor  $C_e$  is defined as a variable CVAL and the setup for parametric sweep is shown in Figure 7.17(b).

Peak voltage  $V_m = 169.7 \text{ V}$ , and  $f = 60 \text{ Hz}$ . The listing of the circuit file is as follows:

**Example 7.4 Single-phase bridge rectifier with RL load**

**SOURCE** ■ VS 1 0 SIN (0 169.7V 60Hz)

**CIRCUIT** ■■ LE 3 7 30.83MH

.PARAM CVAL = 326UF

CE 7 4 326UF

R 7 5 40

L 5 6 10MH

VX 6 4 DC 0V ; Voltage source to measure the output current

VY 1 2 DC 0V ; Voltage source to measure the input current

D1 2 3 DMOD

D3 0 3 DMOD

D2 4 0 DMOD

D4 4 2 DMOD

.STEP PARAM LIST 1UF 100UF 326UF

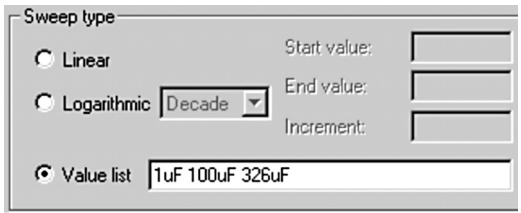
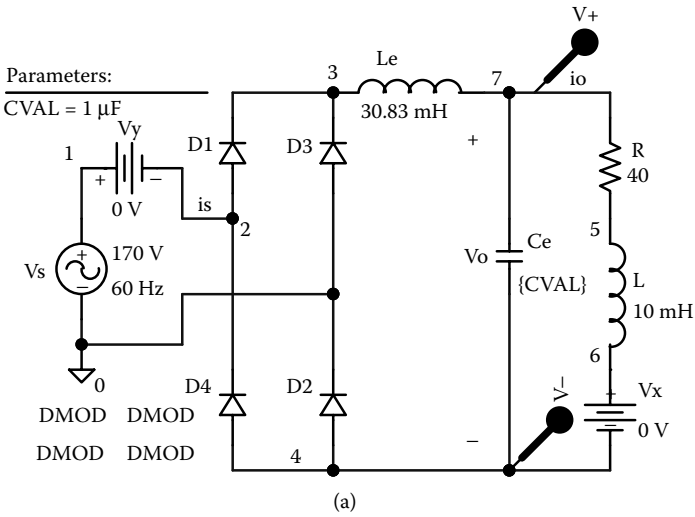
.MODEL DMOD D(IS=2.22E-15 BV=1200V IBV=13E-3 TT=1US)

```

ANALYSIS ■■■ .TRAN 10US 50MS 33.3333MS 10US ; Transient analysis
                .FOUR 120Hz V(7,4)                ; Fourier analysis of
                                                    output voltage

                *
                .PROBE
                .OPTIONS ABSTOL = 1.0 NVNTOL = .01M ITL5 = 10000 ;
                                                    Convergence

                *
                .END
    
```



**FIGURE 7.17** PSpice schematic for Example 7.4. (a) Schematic, (b) parametric setup.

Note the following:

- (a) The PSpice plots of the instantaneous output voltage  $V(7,4)$  and load current  $I(VX)$  are shown in [Figure 7.18](#). The LC filter smooths the load voltage and reduces ripples.

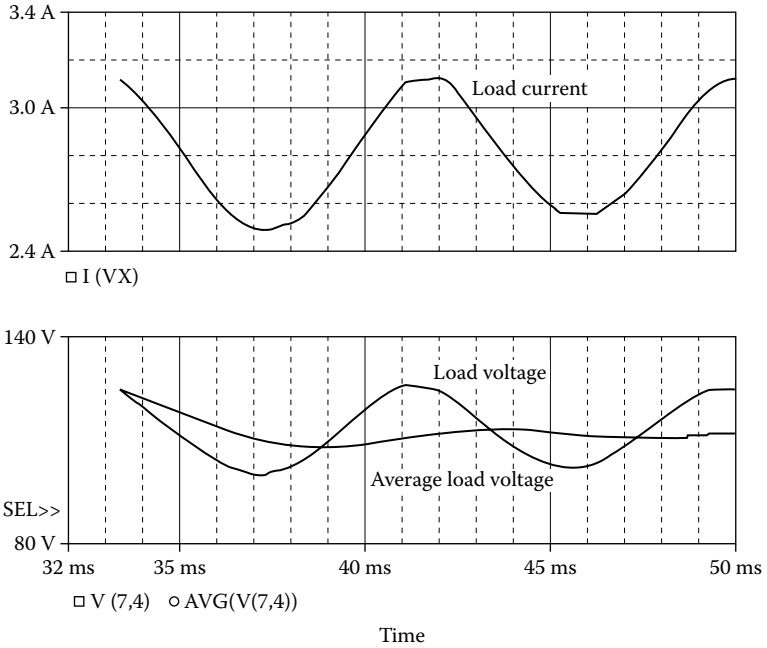


FIGURE 7.18 Plots for Example 7.4.

(b) The Fourier coefficients of the output voltage are:

**FOURIER COMPONENTS OF TRANSIENT RESPONSE V(7,4)**

DC COMPONENT = 1.143072E +02

Harmonic No	Frequency (Hz)	Fourier Component	Normalized Component	Phase (Deg)	Normalized Phase(Deg)
1	1.200E+02	1.306E+01	1.000E+00	1.034E+02	0.000E+00
2	2.400E+02	6.509E-01	4.983E-02	1.225E+02	1.907E+01
3	3.600E+02	2.315E-01	1.772E-02	9.039E+01	-1.305E+01
4	4.800E+02	1.617E-01	1.238E-02	4.774E+01	-5.570E+01
5	6.000E+02	1.316E-01	1.007E-02	2.218E+01	-8.126E+01
6	7.200E+02	1.050E-01	8.039E-03	8.698E+00	-9.474E+01
7	8.400E+02	8.482E-02	6.494E-03	2.760E+00	-1.007E+02
8	9.600E+02	7.149E-02	5.473E-03	5.647E-02	-1.034E+02
9	1.080E+03	6.137E-02	4.699E-03	-2.062E+00	-1.055E+02

TOTAL HARMONIC DISTORTION = 5.666466E + 00 PERCENT

(c) The input current, which is the same as the current through voltage source VY, is equal to I(VY). After running PSpice to obtain the Fourier series of the input current, using the command

.FOUR 60HZ I(VY) ; Fourier analysis of input current  
we get

---

### FOURIER COMPONENTS OF TRANSIENT RESPONSE I(VY)

DC COMPONENT = -2.229026 E+00

Harmonic No	Frequency (Hz)	Fourier Component	Normalized Component	Phase (Deg)	Normalized Phase(Deg)
1	6.000E+01	2.555E+02	1.000E+00	-3.492E+00	0.000E+00
2	1.200E+02	1.146E+00	4.486E-03	1.192E+02	1.227E+02
3	1.800E+02	8.372E+01	3.277E-01	3.125E+00	6.617E+00
4	2.400E+02	1.092E+00	4.273E-03	1.044E+02	1.079E+02
5	3.000E+02	5.024E+01	1.967E-01	1.036E+00	4.528E+00
6	3.600E+02	1.082E+00	4.237E-03	9.819E+01	1.017E+02
7	4.200E+02	3.586E+01	1.404E-01	-1.011E-01	3.391E+00
8	4.800E+02	1.070E+00	4.187E-03	9.446E+01	9.795E+01
9	5.400E+02	2.788E+01	1.091E-01	-9.085E-01	2.583E+00

TOTAL HARMONIC DISTORTION = 4. 216000E+01 PERCENT

---

THD of input current THD = 42.16% = 0.4216

Displacement angle  $\phi_1 = -3.492^\circ$

Displacement factor DF =  $\cos \phi_1 = \cos(-3.492) = 0.9981$  (lagging)

Neglecting the DC input current  $I_{in(DC)} = -2.229$  A, which is small relative to the fundamental component, we can find power factor from Equation 7.3 as

$$PF = \frac{1}{(1 + 0.4216^2)^{1/2}} \times 0.9981 = 0.9197 \text{ (lagging)}$$

- (d) The effects of the filter capacitances on the load voltage are shown in [Figure 7.19](#). With a higher value of the filter capacitor, the steady-state peak-peak ripple on the output voltage is reduced.

### EXAMPLE 7.5 FINDING THE PERFORMANCE OF A THREE-PHASE BRIDGE RECTIFIER

A three-phase bridge rectifier is shown in [Figure 7.20](#). The rectifier is supplied from a balanced three-phase balanced supply whose per-phase voltage has a peak of 169.7 V, 60 Hz. The load inductance  $L$  is 6.5 mH, and the load resistance  $R$  is 0.5  $\Omega$ . Use PSpice (a) to plot the instantaneous output voltage  $v_o$  and line (phase) current  $i_a$ , (b) to plot the rms and average currents of diode  $D_1$ , (c) to plot the average output power, and (d) to calculate the Fourier coefficients of the input current and the input power factor.

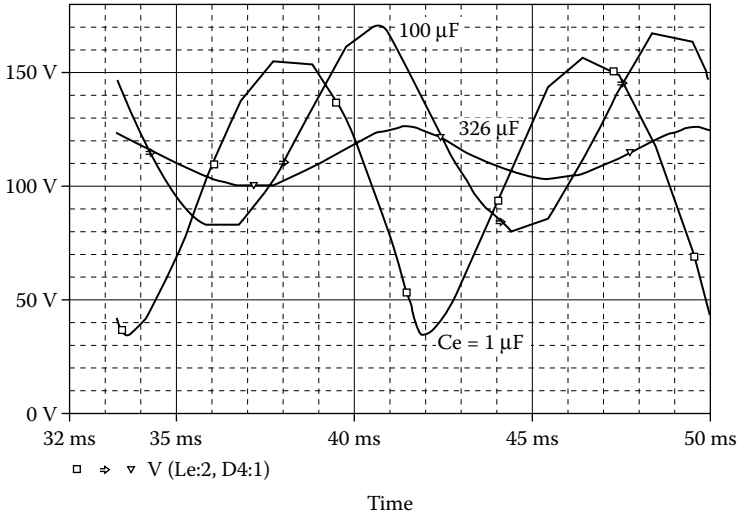


FIGURE 7.19 Effects of filter capacitances for Example 7.4.

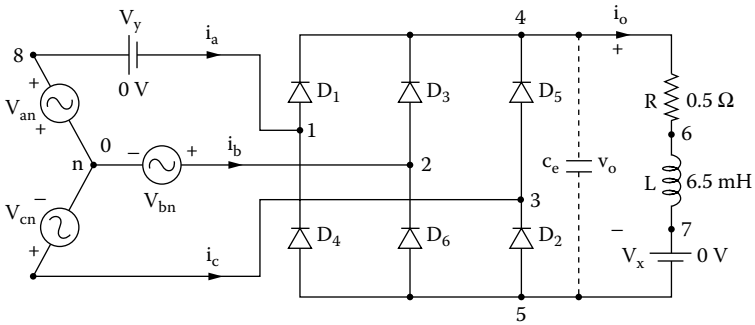


FIGURE 7.20 Three-phase bridge rectifier.

**SOLUTION**

The PSpice schematic is shown in Figure 7.21.

Peak voltage per phase  $V_m = 169.7$  V, and  $f = 60$  Hz. The listing of the circuit file is as follows:

**Example 7.5 Three-phase bridge rectifier**

```

SOURCE ■ Van 8 0 SIN (0 169.7V 60HZ)
        Vbn 2 0 SIN (0 169.7V 60Hz 0 0 120DEG)
        Vcn 3 0 SIN (0 169.7V 60Hz 0 0 240DEG)
    
```

```

CIRCUIT ■■■ CE 4 5 1UF ; Small capacitance to aid convergence
R 4 6 0.5
L 6 7 6.5MH
VX 7 5 DC 0V ; Voltage source to measure the output
                current
VY 8 1 DC 0V ; Voltage source to measure the input
                current

D1 1 4 DMOD
D3 2 4 DMOD
D5 3 4 DMOD
D2 5 3 DMOD
D6 5 2 DMOD
D4 5 1 DMOD
.MODELDMODD (IS=2.2 2E-15 BV=1200V IBV=13E-
3 CJO=2PF TT=1US)
    
```

```

ANALYSIS ■■■ .TRAN 10US 33.3333MS 0 10US ; Transient analysis
.FOUR 60Hz 1(VY) ; Fourier analysis of line
                    current
.PROBE ; Graphics post-processor
.OPTIONS ABSTOL = 1.0N RENTOL = 1.0M VNTOL = 1.0M
                    ITL5=10000 ; Convergence
*
.END
    
```

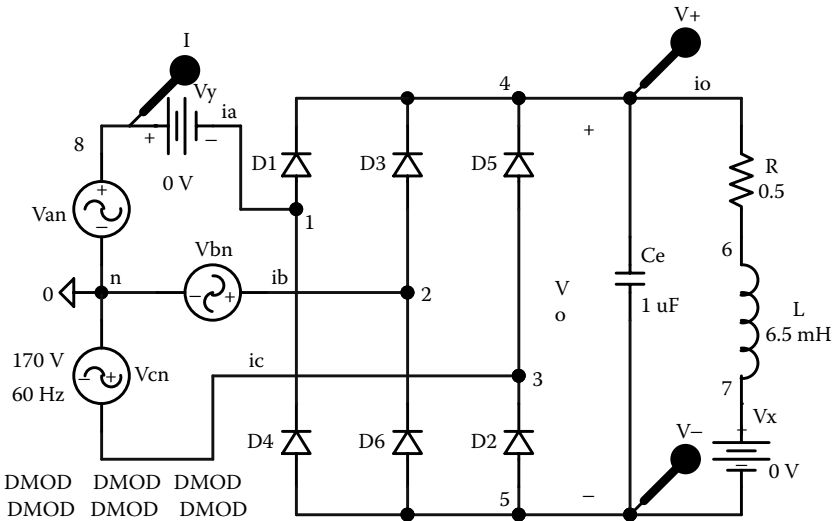


FIGURE 7.21 Three-phase bridge rectifier schematic for Example 7.5.

Note the following:

- (a) The PSpice plots of the instantaneous output voltage  $V(4,5)$  and line current  $I(VY)$  are shown in Figure 7.22. As expected, there are six output pulses over the period of the input voltage. The input current is rectangular.
- (b) The plots of the instantaneous rms and average currents of diode  $D_1$  are shown in Figure 7.23. Averaging over a small time at the very beginning yields a large value. But after a sufficiently long time, it gives the true average or rms values.
- (c) The plot of the instantaneous average output power is shown in Figure 7.24. The average current, rms current, and average power will reach steady-state fixed values if the transient analysis is continued for a longer period.
- (d) The Fourier coefficients of the input current are:

---

**FOURIER COMPONENTS OF TRANSIENT RESPONSE I(VY)**

DC COMPONENT = 2. 066274E-01

Harmonic No	Frequency (Hz)	Fourier Component	Normalized Component	Phase (Deg)	Normalized Phase(Deg)
1	6.000E+01	6.161E+02	1.000E+00	-8.420E-03	0.000E+00
2	1.200E+02	1.182E+00	1.919E-03	-1.692E+02	-1.692E+02
3	1.800E+02	9.265E-01	1.504E-03	-6.353E+00	-6.345E+00
4	2.400E+02	1.219E+00	1.979E-03	-1.767E+02	-1.767E+02
5	3.000E+02	1.227E+02	1.991E-01	1.797E+02	1.797E+02
6	3.600E+02	6.153E-02	9.987E-05	1.145E+02	1.145E+02
7	4.200E+02	8.839E+01	1.435E-01	-1.797E+02	-1.797E+02
8	4.800E+02	1.196E+00	1.941E+00	3.666E+00	3.675E+00
9	5.400E+02	9.152E-01	1.485E-03	1.779E+02	1.779E+02

TOTAL HARMONIC DISTORTION = 2.454718E+01 PERCENT

---

THD of input current,  $THD = 24.55\% = 0.2455$

Displacement angle,  $\phi_1 \approx 0^\circ$

Displacement factor,  $DF = \cos \phi_1 = \cos (0) \approx 1$

Neglecting the DC input current  $I_{in(DC)} = 0.207$  A, which is small relative to the fundamental component, we can find power factor  $PF$  from Equation 7.3 as

$$PF = \frac{1}{(1 + 0.2455^2)^{1/2}} \times 1 = 0.971 \text{ (lagging)}$$

**EXAMPLE 7.6 FINDING THE PERFORMANCE OF A THREE-PHASE BRIDGE RECTIFIER WITH LINE INDUCTANCES**

A three-phase bridge rectifier with the inductances is shown in Figure 7.25. The rectifier is supplied from a balanced three-phase supply whose per-phase voltage has a peak of 169.7 V, 60 Hz. The load inductance  $L$  is 6.5 mH, and the load resistance  $R$  is 0.5  $\Omega$ . The line inductances are equal  $L_1 = L_2 = L_3 = 0.5$  mH. Use PSpice to plot the instantaneous line voltages  $v_{ac}$  and  $v_{bc}$ , and the instantaneous currents through diodes  $D_1$ ,  $D_3$ , and  $D_5$ .

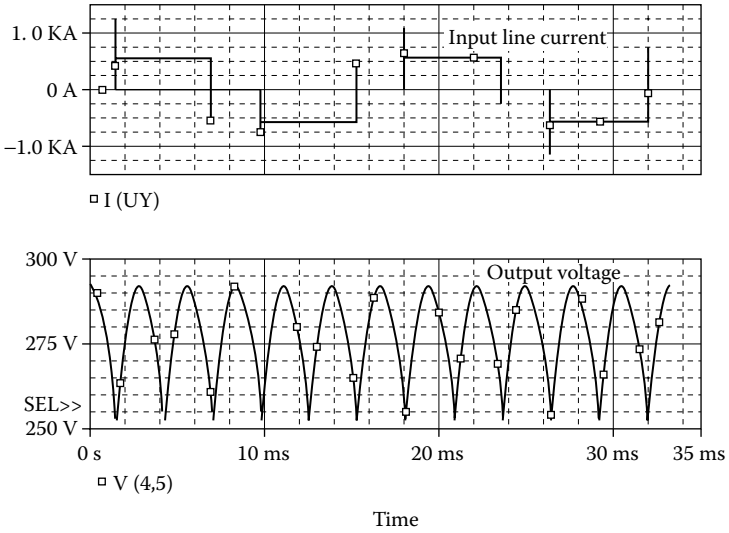


FIGURE 7.22 Plots of output voltage (4,5) and line current  $I(VY)$  for Example 7.5.

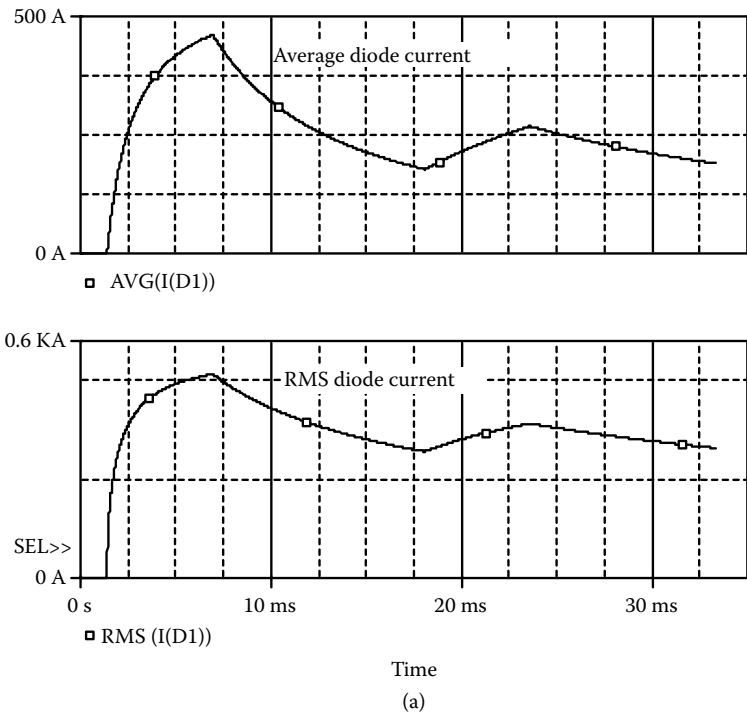


FIGURE 7.23 Plots of rms and average currents through diode D1 for Example 7.5.

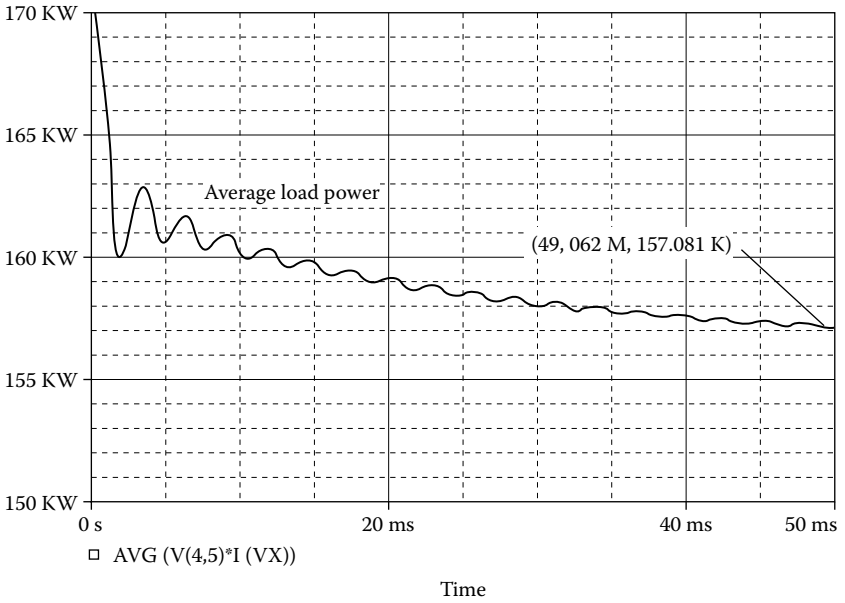


FIGURE 7.24 Instantaneous load power for Example 7.5.

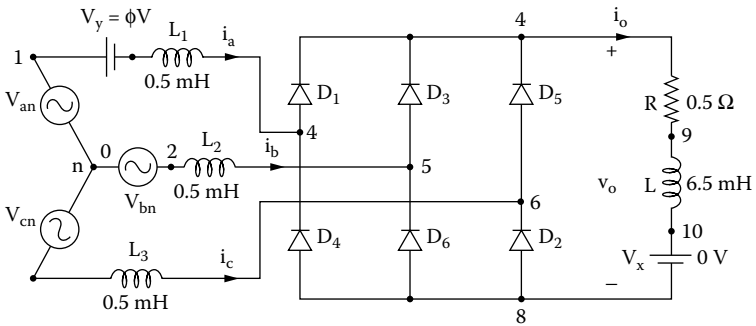
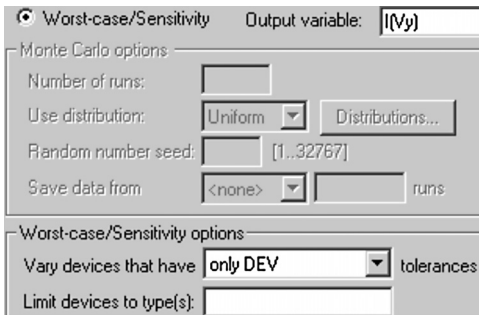
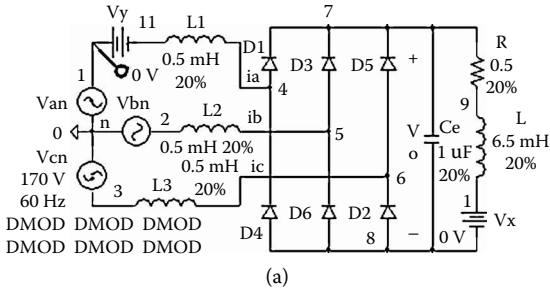


FIGURE 7.25 Three-phase bridge rectifier with source inductance.

Plot the worst-case line current  $i_a$  if the resistances, the inductances and capacitances change by  $\pm 20\%$ .

**SOLUTION**

The PSpice schematic is shown in Figure 7.26(a). The DC voltage VY is used to measure the line current. The setup for worst-case analysis is shown in Figure 7.26(b).



**FIGURE 7.26** Three-phase bridge rectifier with line inductances for Example 7.6. (a) Schematic, (b) worst-case setup

Peak phase voltages  $V_m = 169.7$  V, and  $f = 60$  Hz. The listing of the circuit file is as follows:

**Example 7.6 Three-phase bridge rectifier with source inductances**

```

SOURCE   ■ Van 1 0 SIN (0 169.7V 60HZ)
CIRCUIT  ■■ L1 11 4 0.5MH
          Vbn 2 0 SIN (0 169.7V 60HZ 0 0 120DEG)
          L2 2 5 0.5MH
          Vcn 3 0 SIN (0 169.7V 60HZ 0 0 240DEG)
          Vy 1 11 DC
          L3 3 6 0.5MH
          R 7 9 0.5
          L 9 10 6.5MH
          VX 10 8 DC 0V ; Voltage source to measure the output
                        current
          D1 4 7 DMOD
          D3 5 7 DMOD
    
```

```

D5  6  7  DMOD
D2  8  6  DMOD
D6  8  5  DMOD
D4  8  4  DMOD
.MODEL DMOD D(IS=2.22E-15 BV=1200V IBV=13E-
3 CJO=2PF TT=1US)

```

```

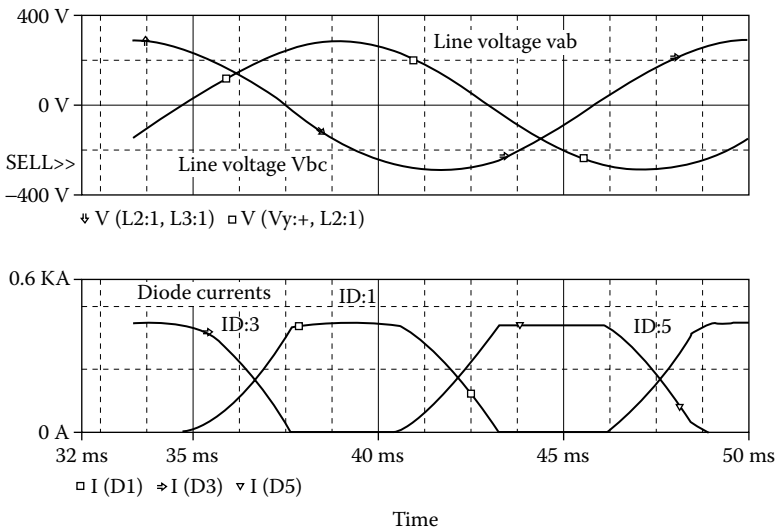
ANALYSIS ■■■ .TRAN 10US 50MS 33.3333MS 10US ; Transient analysis
.PROBE ; Graphics post-processor
.OPTIONS ABSTOL = 0.0NRELTOL = 0.01VNVTOL = 1.0M
ITL5 = 10000 ; Convergence
.END

```

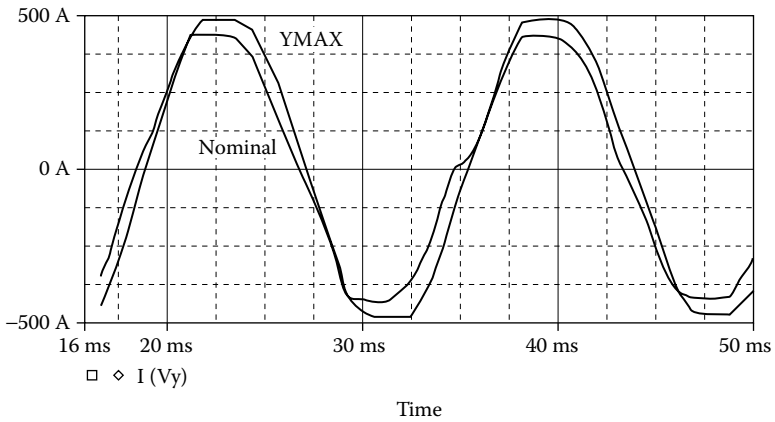
The PSpice plots of the instantaneous currents through diode  $D_1$ ,  $I(D1)$ , through diode  $D_3$   $I(D3)$ , and through diode  $D_5$ ,  $I(D5)$ , and the line voltages  $V(1,3)$  and  $V(2,3)$  are shown in Figure 7.27. Because of the source inductances, a commutation interval exists. During this interval, the current through the incoming diode rises and that through the outgoing diode falls. The sum of these currents must equal the load current.

The worst-case line current is shown in Figure 7.28.

*Note:* Because of the line inductances, there is a transition time for switching the line currents from one diode to another diode as shown in Figure 7.27. This causes a drop in the output voltage because of the commutation of the currents [1].



**FIGURE 7.27** Plots of line voltages and diode currents for Example 7.6



**FIGURE 7.28** Worst-case plot of the line current for Example 7.6

## 7.7 LABORATORY EXPERIMENTS

It is possible to develop many experiments for demonstrating the operation and characteristics of diode rectifiers. The following three experiments are suggested:

- Single-phase full-wave center-tapped rectifier
- Single-phase bridge rectifier
- Three-phase bridge rectifier

### 7.7.1 EXPERIMENT DR.1

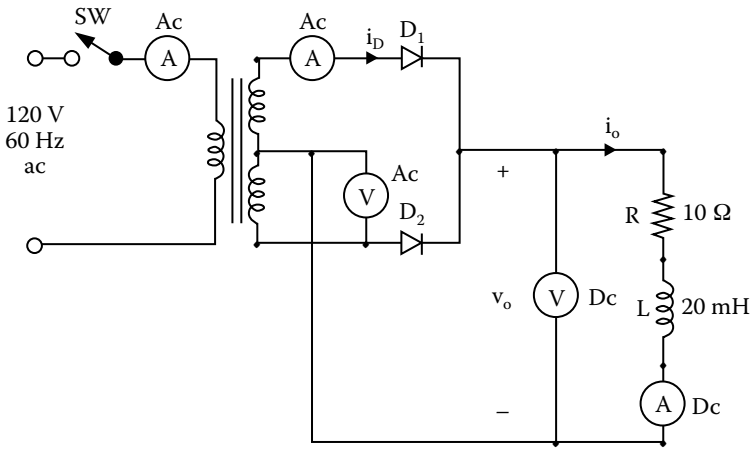
#### SINGLE-PHASE FULL-WAVE CENTER-TAPPED RECTIFIER

- Objective** To study the operation and characteristics of a single-phase full-wave rectifier under various load conditions.
- Applications** A single-phase full-wave rectifier is used as an input stage in power supplies, etc.
- Textbook** See [Reference 1](#), Section 3.8 and Section 3.9.
- Apparatus**
1. Two diodes with ratings of at least 50 A and 400 V, mounted on heat sinks
  2. One center-tapped (step-down) transformer
  3. An  $RL$  load
  4. One dual-beam oscilloscope with floating or isolating probes
  5. AC and DC voltmeters and ammeters and one noninductive shunt
- Warning** Before making any circuit connection, switch off the AC power. Do not switch on the power unless the circuit is checked and approved by your laboratory instructor. Do not touch the diode heat sinks, which are connected to live terminals.
- Experimental procedure**
1. Setup the circuit as shown in [Figure 7.29](#). Use the load resistance  $R$  only.
  2. Connect the measuring instruments as required.

3. Observe and record the waveforms of the load voltage  $v_o$  and the load current  $i_o$ .
4. Measure the average load voltage  $V_{o(DC)}$ , the rms load voltage  $V_{o(rms)}$ , the average load current  $I_{o(DC)}$ , the rms load current  $I_{o(rms)}$ , the rms input current  $I_{s(rms)}$ , the rms input voltage  $V_{s(rms)}$ , and the average load power  $P_L$ .
5. Repeat steps 2 to 4 with the load inductance  $L$  only.
6. Repeat steps 2 to 4 with both load resistance  $R$  and load inductance  $L$ .

**Report**

1. Present all recorded waveforms and discuss all significant points.
2. Compare the waveforms generated by SPICE with the experimental results, and comment.
3. Compare the experimental results with the results predicted.
4. Discuss the advantages and disadvantages of this type of rectifier.

**FIGURE 7.29** Single-phase full-wave rectifier.**7.7.2 EXPERIMENT DR.2****SINGLE-PHASE BRIDGE RECTIFIER**

- Objective** To study the operation and characteristics of single-phase bridge-rectifier under various load conditions.
- Applications** A single-phase bridge rectifier is used as an input stage power supplies, variable-speed AC/DC motor drives, etc.
- Textbook** See [Reference 1](#), Section 3.8 and Section 3.9.
- Apparatus** Same as Experiment DR.1, except that four diodes are required.
- Warning** See [Experiment DR.1](#).
- Experimental procedure** Set up the circuit as shown in [Figure 7.30](#) and follow the steps for Experiment DR.1.
- Report** Repeat the steps of Experiment DR.1.

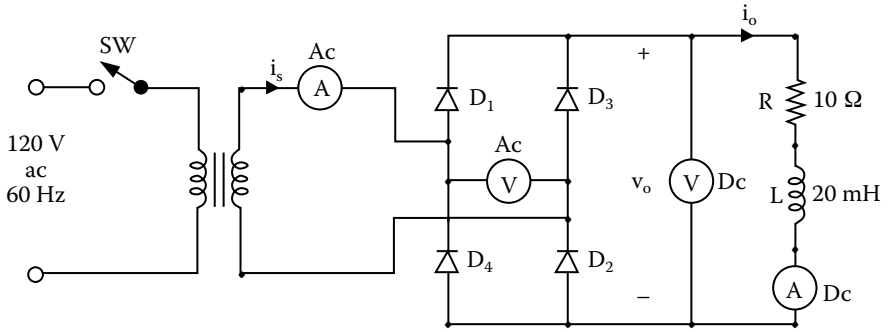


FIGURE 7.30 Single-phase bridge rectifier.

### 7.7.3 EXPERIMENT DR.3

#### THREE-PHASE BRIDGE RECTIFIER

- Objective** To study the operation and characteristics of a three-phase bridge rectifier under various load conditions.
- Applications** A three-phase bridge rectifier is used as an input stage in variable-speed AC motor drives, etc.
- Textbook** See Reference 1, Section 3.11 and Section 3.12.
- Apparatus** Same as Experiment DR.1, except that six diodes are required.
- Warning** See Experiment DR.1.
- Experimental procedure** Set up the circuit as shown in Figure 7.31 and follow the steps for Experiment DR.1.
- Report** Repeat the steps of Experiment DR.1.

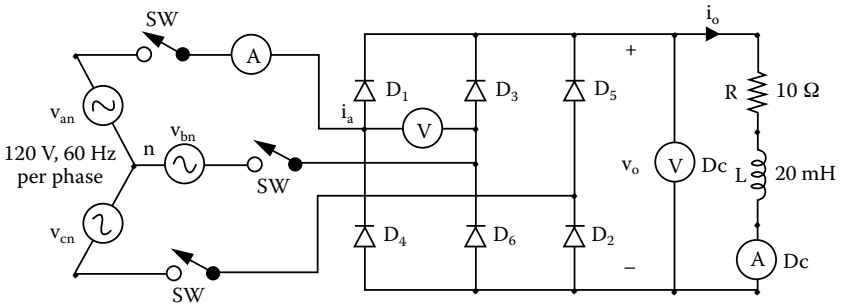


FIGURE 7.31 Three-phase bridge rectifier.

## 7.8 SUMMARY

The statements for diodes are:

```
D<name> NA NK DNAME [(area) value]
.MODEL DNAME TYPE(P1=V1 P2=V2 P3=V3 ... PN=VN)

I(D1)           Instantaneous current through diode  $D_1$ 
RMS(I(D1))     Rms current of diode  $D_1$ 
AVG(I(D1))     Average current of diode  $D_1$ 
V(D1)          Instantaneous anode to cathode voltage of diode  $D_1$ 
```

## Suggested Reading

1. M.H. Rashid, *Power Electronics: Circuit, Devices and Applications*, 3rd ed., Englewood Cliff, NJ: Prentice-Hall, 2003, chap. 2 and 3.
2. M.H. Rashid, *Introduction to PSpice Using OrCAD for Circuits and Electronics*, 3rd ed., Englewood Cliff, NJ: Prentice-Hall, 2003 chap. 7.
3. M.H. Rashid, *SPICE For Power Electronics and Electric Power*, Englewood Cliff, NJ: Prentice-Hall, 1993.
4. P. Antognetti, *Power Integrated Circuits*, New York: McGraw-Hill, 1986.
5. *PSpice Manual*, Irvine, CA: MicroSim Corporation, 1988.

## DESIGN PROBLEMS

### 7.1

Design the single-phase full-wave rectifier of [Figure 7.29](#) with the following specifications:

AC supply voltage  $V_s = 120$  V (rms), 60 Hz

Load Resistance  $R = 5$   $\Omega$

Load inductance  $L = 15$  mH

DC output voltage  $V_{o(\text{DC})} = 24$  V

- (a) Determine the ratings of all components and devices.
- (b) Use SPICE to verify your design.
- (c) Provide a cost estimate of the circuit.

### 7.2

- (a) Design an output  $C$  filter for the single-phase full-wave rectifier of Problem 7.2. The harmonic content of the load current should be less than 5% of the value without the filter.
- (b) Use SPICE to verify your design in part (a).

### 7.3

Design the single-phase bridge rectifier of [Figure 7.30](#) with the following specifications:

AC supply voltage  $V_s = 120\text{V}$  (rms), 60 Hz load resistance  $R = 5\Omega$

Load inductance  $L = 15\text{mH}$

DC output voltage  $V_{o(\text{DC})} = 48\text{V}$

- Determine the ratings of all components and devices.
- Use SPICE to verify your design.
- Provide a cost estimate of the circuit.

### 7.4

- Design an output  $LC$  filter for the single-phase bridge rectifier of Problem 7.4. The harmonic content of the load current should be less than 5% of the value without the filter.
- Use SPICE to verify your design in part (a).

### 7.5

- Design an output  $C$  filter for the single-phase bridge rectifier of Problem 7.4. The harmonic content of the load voltage should be less than 5% of the value without the filter.
- Use SPICE to verify your design in part (a).

### 7.6

The rms input voltage to the single-phase bridge rectifier of [Figure 7.30](#) is 120V, 60Hz, and it has an output  $LC$  filter. If the DC output voltage is  $V_{\text{DC}} = 48\text{V}$  at  $I_{\text{DC}} = 25\text{A}$ , determine the value of filter inductance  $L$ .

### 7.7

It is required to design the three-phase bridge rectifier of [Figure 7.31](#) with the following specifications:

AC supply voltage per phase  $V_s = 120\text{V}$ (rms), 60 Hz

Load resistance  $R = 5\Omega$

Load inductance  $L = 15\text{mH}$

DC output voltage  $V_{o(\text{DC})} = \text{maximum possible value}$

- Determine the ratings of all components and devices.
- Use SPICE to verify your design.
- Provide a cost estimate of the circuit.

## 7.8

- Design an output  $LC$  filter for the three-phase bridge rectifier of Problem 7.7. The harmonic content of the load current should be less than 5% of the value without the filter.
- Use SPICE to verify your design in part (a).

## 7.9

- Design an output  $C$  filter for the three-phase bridge rectifier of Problem 7.7. The harmonic content of the load voltage should be less than 5% of the value without the filter.
- Use SPICE to verify your design in part (a).

## 7.10

Repeat Example 7.2 with an antiparallel (or freewheeling) diode connected across the terminals 2 and 0 of Figure 7.10. Complete the following table.

Rectifier	% THD of Input Current, $\text{THD}_i$	Input Power Factor, $\text{PF}_i$	% THD of Output Voltage, $\text{THD}_{v_o}$	% THD of Load Current, $\text{THD}_{i_o}$
Half-wave				
Half-wave with a freewheeling diode				

## 7.11

Complete the following table for the single-phase half-wave rectifier in Figure 7.10, the single-phase bridge rectifier in Figure 7.13 and the three-phase bridge rectifier in Figure 7.20.

Rectifier	% THD of Input Current, $\text{THD}_i$	Input Power Factor, $\text{PF}_i$	% THD of Output Voltage, $\text{THD}_{v_o}$	% THD of Load Current, $\text{THD}_{i_o}$
Single-phase half-wave rectifier				
Single-phase bridge rectifier				
Three-phase bridge rectifier				

## 7.12

Complete the following tables to find the effects of output filter capacitances on the performance of the single-phase half-wave rectifier in [Figure 7.10](#), the single-phase bridge rectifier in [Figure 7.13](#) and the three-phase bridge rectifier in [Figure 7.20](#).

TABLE P7.12(A)

Filter Capacitance $C_e = 1 \mu\text{F}$	% THD of Input Current, $\text{THD}_i$	Input Power Factor, $\text{PF}_i$	% THD of Output Voltage, $\text{THD}_{v_o}$	% THD of Load Current, $\text{THD}_{i_o}$
Single-phase half-wave rectifier				
Single-phase bridge rectifier				
Three-phase bridge rectifier				

TABLE P7.12(B)

Filter Capacitance $C_e = 300 \mu\text{F}$	% THD of Input Current, $\text{THD}_i$	Input Power Factor, $\text{PF}_i$	% THD of Output Voltage, $\text{THD}_{v_o}$	% THD of Load Current, $\text{THD}_{i_o}$
Single-phase half-wave rectifier				
Single-phase bridge rectifier				
Three-phase bridge rectifier				

TABLE P7.12(C)

Filter Capacitance $C_e = 600 \mu\text{F}$	% THD of Input Current, $\text{THD}_i$	Input Power Factor, $\text{PF}_i$	% THD of Output Voltage, $\text{THD}_{v_o}$	% THD of Load Current, $\text{THD}_{i_o}$
Single-phase half-wave rectifier				
Single-phase bridge rectifier				
Three-phase bridge rectifier				

---

# 8 DC–DC Converters

The learning objectives of this chapter are:

- Modeling BJTs, MOSFETs, and IGBTs in SPICE and specifying their mode parameters
- Modeling of PWM control in SPICE and as a hierarchy block
- Performing transient analysis of DC–DC converters
- Evaluating the performance of DC–DC converters
- Performing worst-case analysis of diode rectifiers for parametric variations of model parameters and tolerances

## 8.1 INTRODUCTION

In a DC–DC converter, both input and output voltages are DC. It uses a power semiconductor device as a switch to turn on and off the DC supply to the load. The switching action can be implemented by a BJT, a MOSFET, or an IGBT. A DC–DC converter with only one switch is often known as a DC chopper.

## 8.2 DC SWITCH CHOPPER

A chopper switch is shown in [Figure 8.1\(a\)](#). If switch  $S_1$  is turned on, the supply voltage  $V_S$  is connected to the load. If the switch is turned off, the inductive load current  $i_o$  is forced to flow through diode  $D_m$ . The output voltage and load current are shown in [Figure 8.1\(b\)](#). The parameters of the switch can be adjusted to model the voltage drop of the chopper. We use the switch parameters  $R_{ON} = 1M$ ,  $R_{OFF} = 10E+6$ ,  $V_{ON} = 1V$ , and  $V_{OFF} = 0V$  and the diode parameters  $I_S = 2.22E-15$ ,  $BV = 1200V$ ,  $CJO = 0F$ , and  $TT = 0$ . The diode parasitics are neglected; however, they will affect the transient behavior.

### EXAMPLE 8.1 FINDING THE PERFORMANCE OF A STEP-DOWN DC–DC CONVERTER WITH A VOLTAGE CONTROLLED SWITCH

A DC chopper switch is shown in [Figure 8.2\(a\)](#). The DC input voltage is  $V_S = 220V$ . The load resistance  $R$  is  $5\ \Omega$ , and the load inductance  $L = 7.5\text{ mH}$ . The chopping frequency is  $f_o = 1\text{ kHz}$ , and the duty cycle of the chopper is  $k = 50\%$ . The control voltage is shown in [Figure 8.2\(b\)](#). Use PSpice to (a) plot the instantaneous output voltage  $v_o$ , the load current  $i_o$ , and the diode current  $i_{D_m}$ , (b) calculate the Fourier coefficients of the load current  $i_o$ , and (c) calculate the Fourier coefficients of the input current  $i_s$ .

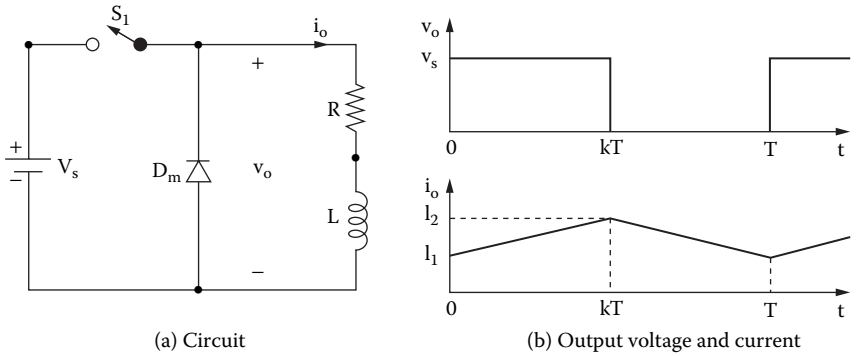


FIGURE 8.1 DC switch chopper. (a) Circuit, (b) output voltage and current.

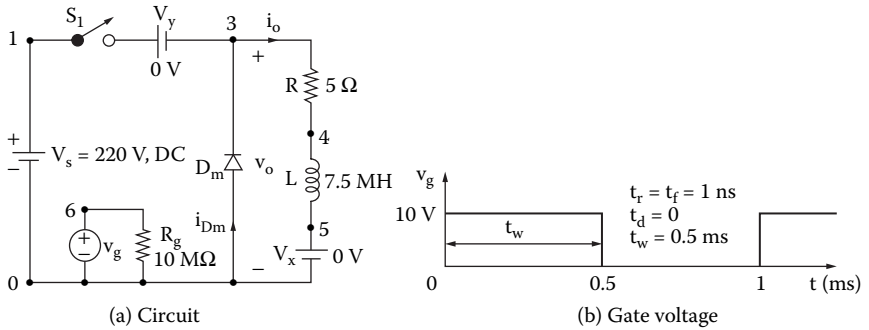


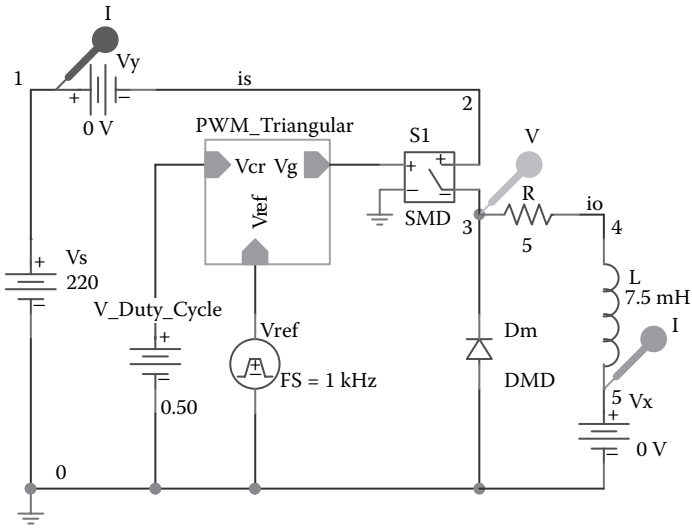
FIGURE 8.2 DC chopper for PSpice simulation. (a) Circuit, (b) gate voltage.

**SOLUTION**

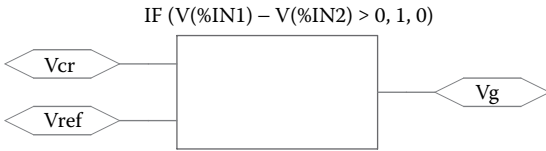
The DC supply voltage  $V_s = 220\text{ V}$ ,  $k = 0.5$ ,  $f_o = 1\text{ kHz}$ ,  $T = 1/f_o = 1\text{ msec}$ , and  $t_{on} = k \times T = 0.5 \times 1\text{ msec} = 0.5\text{ msec}$ .

The corresponding PSpice schematic is shown in Figure 8.3(a). Comparing a triangular signal  $V_{ref}$  with a carrier signal  $V_{cr}$  generates a PWM waveform. The PWM generator is implemented as a descending hierarchy as shown in Figure 8.3(b). An ABM2 device that compares the two signals produces a square wave output between 0 to 1 V to drive the voltage control switch. Varying the voltage  $V_{Duty\_Cycle}$  can vary the duty cycle of the switch and the average output voltage. The model parameters for the switch and the freewheeling diode are as follows:

```
.MODEL SMD VSWITCH (RON=1M ROFF=10E6 VON=1V VOFF=0V)
.MODEL DMD D(IS=2.22E-15 BV=1200V CJO=1PF TT=0US)
```



(a)



(b)

**FIGURE 8.3** PSpice schematic for Example 8.1. (a) Schematic, (b) descending hierarchy comparator.

The list of the circuit file is as follows:

**EXAMPLE 8.1 Chopper circuit**

```

SOURCE  ■ VS 1 0 DC 220V
        Vg 6 0 PULSE (0V 10V 0 1NS 1NS 0.5MS 1MS)
        Rg 6 0 10MEG
CIRCUIT  ■■ R 3 4 5
          L 4 5 7.5MH
          VX 5 0 DC 0V ; Load battery voltage
          VY 2 3 DC 0V ; Voltage source to measure chopper current
          DM 0 3 DMOD ; Freewheeling diode
          .MODEL DMOD D(IS=2.22E-15 BV=1200V CJO=0PF TT=0) ;
                   Diode model
          S1 1 2 6 0 SMOD ; Switch
          .MODEL SMOD VSWITCH (RON=1M ROFF=10E+6 VON=1V VOFF=0V)
    
```

```

ANALYSIS ■■■ .TRAN 1US 10MS 8MS ; Transient analysis
               .PROBE ; Graphics post-processor
               .OPTIONS ABSTOL = 1.00N RELTOL = 0.01 VNTOL = 0.1
                   ITL5 = 40000
               .FOUR 1KHZ I(VX) I(VY) ; Fourier analysis
               . END

```

Note the following:

- The PSpice plots of the instantaneous input current I(VY), the current through diode I(DM), and the output voltage V(3) are shown in [Figure 8.4](#). The load current rises when the switch is on and falls when it is off.
- The Fourier coefficients of the load current are:

---

### FOURIER COMPONENTS OF TRANSIENT RESPONSE I(VX)

DC COMPONENT = 2.189331E+01

Harmonic No	Frequency (Hz)	Fourier Component	Normalized Component	Phase (Deg)	Normalized Phase (Deg)
1	1.000E+03	2.955E+00	1.000E+00	-8.439E+01	0.000E+00
2	2.000E+03	2.378E-03	8.046E-04	-1.523E+02	-6.789E+01
3	3.000E+03	3.344E-01	1.132E-01	-8.743E+01	-3.040E+00
4	4.000E+03	5.029E-03	1.702E-03	-1.868E+01	6.570E+01
5	5.000E+03	1.147E-01	3.882E-02	-9.128E+01	-6.896E+00
6	6.000E+03	5.937E-03	2.009E-03	1.115E+02	1.959E+02
7	7.000E+03	6.417E-02	2.171E-02	-9.042E+01	-6.036E+00
8	8.000E+03	2.062E-03	6.979E-04	-1.602E+02	-7.578E+01
9	9.000E+03	3.747E-02	1.268E-02	-9.349E+01	-9.108E+00

TOTAL HARMONIC DISTORTION = 1.222766E+01 PERCENT

---

- The Fourier coefficients of the input current are:

---

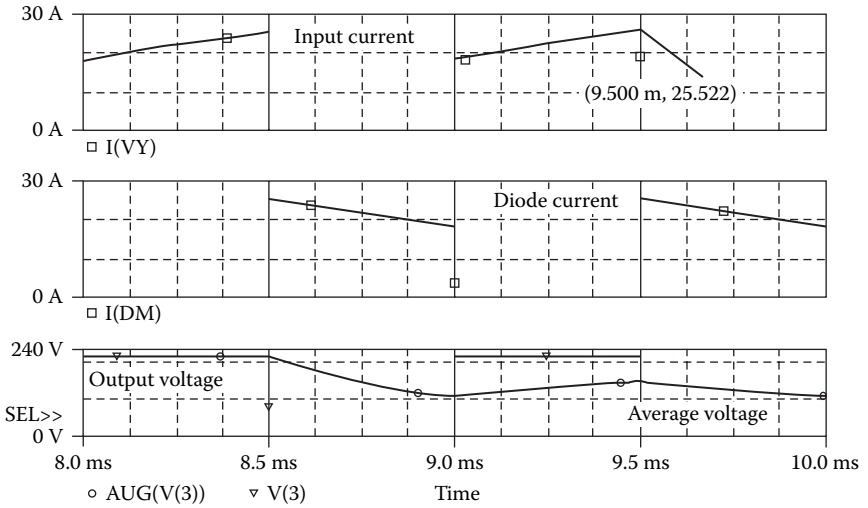
### FOURIER COMPONENT OF TRANSIENT RESPONSE I(VY)

DC COMPONENT = 1.113030E+01

Harmonic No	Frequency (Hz)	Fourier Component	Normalized Component	Phase (Deg)	Normalized Phase (Deg)
1	1.000E+03	1.414E+01	1.000E+00	-5.237E+00	0.000E+00
2	2.000E+03	1.167E+00	8.254E-02	1.739E+02	1.792E+02
3	3.000E+03	4.652E+00	3.289E-01	1.861E-01	5.423E+00
4	4.000E+03	6.127E-01	4.333E-02	1.647E+02	1.699E+02
5	5.000E+03	2.784E+00	1.969E-01	2.486E+00	7.722E+00
6	6.000E+03	4.410E-01	3.118E-02	1.563E+02	1.615E+02
7	7.000E+03	1.995E+00	1.411E-01	4.250E+00	9.487E+00
8	8.000E+03	3.622E-01	2.561E-02	1.509E+02	1.561E+02
9	9.000E+03	1.552E+00	1.098E-01	5.976E+00	1.121E+01

TOTAL HARMONIC DISTORTION = 4.350004E+01 PERCENT

---



**FIGURE 8.4** Plots for Example 8.1.

*Note:* When the switch is on, the load current rises. When the switch is off, the load current falls through the freewheeling diode  $D_m$ . For a duty cycle of  $k = 0.5$ , the average output voltage [1] is  $V_{o(av)} = k V_s = 0.5 \times 220 = 110V$  (PSpice also gives 110 V).

### 8.3 BJT SPICE MODEL

SPICE generates a complex model of BJTs. The model equations that are used by SPICE are described in Reference 1 and Reference 2. If a complex model is not necessary, many model parameters can be ignored by the users, and PSpice assigns default values to them. The PSpice model, which is based on the integral charge-control model of Gummel and Poon [1,2], is shown in Figure 8.5(a). The static (DC) model that is generated by PSpice is shown in Figure 8.5(b).

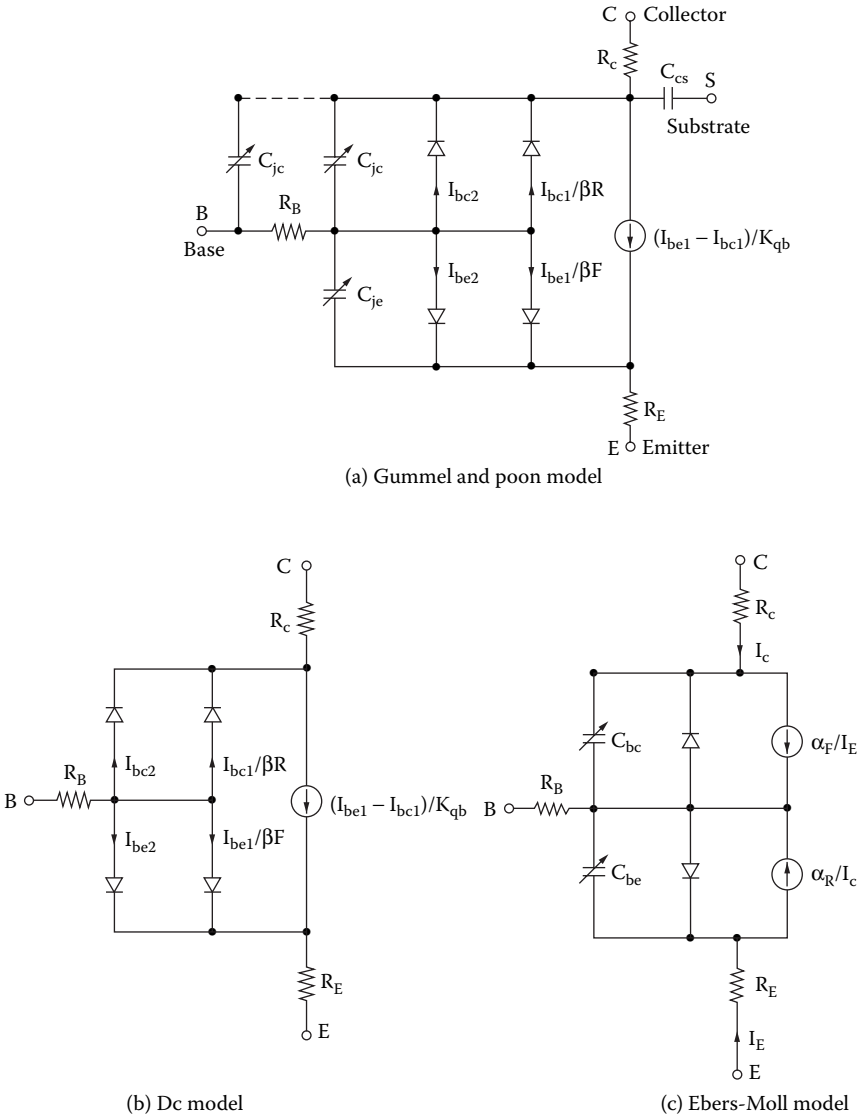
The model statement for NPN transistors has the general form

```
.MODEL QNAME NPN (P1=V1 P2=V2 P3=V3 ... PN=VN)
```

and the general form for PNP transistors is

```
.MODEL QNAME PNP (P1=V1 P2=V2 P3=V3 ... PN=VN)
```

where QNAME is the name of the BJT model. NPN and PNP are the type symbols for NPN and PNP transistors, respectively. QNAME, which is the model name, can begin with any character and its word size is normally limited to eight characters. P1, P2, ... and V1, V2, ... are the parameters and their values, respectively. Table 8.1 shows the model parameters of BJTs. If certain parameters are not specified, PSpice assumes the simple model of Ebers and Moll [3], which is shown in Figure 8.5(c).



**FIGURE 8.5** PSpice BJT model. (a) Gummel and Poon model, (b) DC model, (c) Ebers–Moll model.

The area factor is used to determine the number of equivalent parallel BJTs of the model specified. The model parameters, which are affected by the area factor, are marked with an asterisk (\*) in Table 8.1. A bipolar transistor is modeled as an intrinsic transistor with ohmic resistances in series with the collector ( $R_C/\text{area}$ ), the base ( $R_B/\text{area}$ ), and the emitter ( $R_E/\text{area}$ ). [ $\text{area}$  value] is the relative device area, defaults to 1. For those parameters that have alternative

**TABLE 8.1**  
**Model Parameters of BJTS**

Name	Area	Model Parameter	Unit	Default	Typical
IS	*	$p$ - $n$ Saturation current	A	1E–16	1E–16
BF		Ideal maximum forward beta		100	100
NF		Forward current emission coefficient		1	1
VAF(VA)		Forward Early voltage	V	•	100
IKF(IK)		Corner for forward beta high-current roll-off	A	•	10M
ISE(C2)		Base–emitter leakage saturation current	A	0	1000
NE		Base–emitter leakage emission coefficient		1.5	2
BR		Ideal maximum reverse beta		1	0.1
NR		Reverse current emission coefficient		1	
VAR(VB)		Reverse Early voltage	V	•	100
IKR	*	Corner for reverse beta high-current roll-off	A	•	100M
ISC(C4)		Base–collector leakage saturation current	A	0	1
NC		Base–collector leakage emission coefficient		2	2
RB	*	Zero-bias (maximum) base resistance	W	0	100
RBM		Minimum base resistance	W	RB	100
IRB		Current at which RB falls halfway to RBM	A	•	
RE	*	Emitter ohmic resistance	W	0	1
RC	*	Collector ohmic resistance	W	0	10
CJE	*	Base–emitter zero-bias $p$ - $n$ capacitance	F	0	2P
VJE(PE)		Base–emitter built-in potential	V	0.75	0.7
MJE(ME)		Base–emitter $p$ - $n$ grading factor	0.33	0.33	
CJC	*	Base–collector zero-bias $p$ - $n$ capacitance	F	0	1P
VJC(PC)		Base–collector built-in potential	V	0.75	0.5
MJC(MC)		Base–collector $p$ - $n$ grading factor	0.33	0.33	
XCJC		Fraction of $C_{bc}$ connected internal to $R_b$		1	
CJS(CCS)		Collector–substrate zero-bias $p$ - $n$ capacitance	F	0	2PF
VJS(PS)		Collector–substrate built-in potential	V	0.75	
MJS(MS)		Collector–substrate $p$ - $n$ grading factor		0	
FC		Forward-bias depletion capacitor coefficient		0.5	
TF		Ideal forward transit time	sec	0	0.1NS
XTF		Transit-time bias dependence coefficient		0	
VTF		Transit-time dependency on $V_{bc}$	V	•	
ITF		Transit-time dependency on $I_c$	A	0	
PTF		Excess phase at $1/(2\pi \times TF)$ Hz	degree	0	30°
TR		Ideal reverse transit time	sec	0	10NS
EG		Band-gap voltage (barrier height)	eV	1.11	1.11
XTB		Forward and reverse beta temperature coefficient		0	
XTI(PT)		IS temperature effect exponent		3	
KF		Flicker noise coefficient		0	6.6E–16
AF		Flicker noise exponent		1	1

names such as VAF and VA (the alternative name is indicated in parentheses), either name may be used.

The parameters ISE (C2) and ISC (C4) may be set to be greater than 1. In this case they are interpreted as multipliers of IS instead of absolute currents: that is, if  $ISE > 1$ , it is replaced by  $ISE \cdot IS$ , and similarly for ISC. The DC model is defined by (1) parameters BF, C2, IK, and NE, which determine the forward current gain, (2) BR, C4, IKR, and VC, which determine the reverse current gain characteristics, (3) VA and VB, which determine the output conductance for forward and reverse regions, and (4) the reverse saturation current IS.

Base-charge storage is modeled by (1) forward and reverse transit times TF and TR, and nonlinear depletion-layer capacitances, which are determined by CJE, PE, and ME for a base-emitter junction, and (2) CJC, PC, and MC for a base-collector junction. CCS is a constant collector-substrate capacitance. The temperature dependence of the saturation current is determined by the energy gap EG and the saturation current temperature exponent PT.

The parameters that affect the switching behavior of a BJT are the most important ones for power electronics applications: IS, BF, CJE, CJC, and TF. The symbol of a bipolar junction transistor (BJT) is Q. The name of a bipolar transistor must start with Q and it takes the general form

```
Q<name> NC NB NE NS QNAME [(area) value]
```

where NC, NB, NE, and NS are the collector, base, emitter, and substrate nodes, respectively. QNAME could be any name of up to eight characters. The substrate node is optional: If not specified, it defaults to ground. Positive current is the current that flows into a terminal. That is, the current flows from the collector node, through the device, to the emitter node for an NPN BJT.

## 8.4 BJT PARAMETERS

The data sheet for power transistor 2N6546 is shown in [Figure 8.6](#). SPICE parameters are not available from the data sheet. Some versions of SPICE (e.g., PSpice) support device library files. The software PARTS of PSpice can generate SPICE models from the data sheet parameters of transistors and diodes. Although PSpice allows one to specify many parameters, we shall use only those parameters that affect significantly the output of a power converter [8,9]. From the data sheet we get

$$I_{C(\text{rated})} = 10 \text{ A}$$

$$V_{BE} = 0.8 \text{ V at } I_C = 2 \text{ A}$$

Assuming that  $n = 1$  and  $V_T = 25.8 \text{ mV}$ , we can apply Equation 7.1 to find the saturation current  $I_s$ :

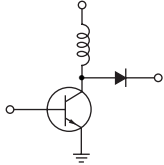
**Designers Data Sheet**

**SWITCHMODE SERIES  
NPN SILICON POWER TRANSISTORS**

The 2N6546 and 2N6547 transistors are designed for high-voltage, high-speed, power switching in inductive circuits where fall time is critical. They are particularly suited for 115 and 220 volt line operated switch-mode applications such as:

- Switching regulators
- PWM inverters and motor controls
- Solenoid and relay drivers
- Deflection circuits

Specification features:-  
High temperature performance specified for:  
Reversed biased SOA with inductive loads  
Stitching times with inductive loads  
Saturation voltages  
Leakage currents



15 AMPERE  
NPN SILICON  
POWER TRANSISTORS

300 and 400 VOLTS  
175 WATTS

**Designer's data for  
"Worst Case" Conditions**

The designers data sheet permits the design of most circuits entirely from the information presented. Limit data—representing device characteristics boundaries—are given to facilitate "worst case" design.

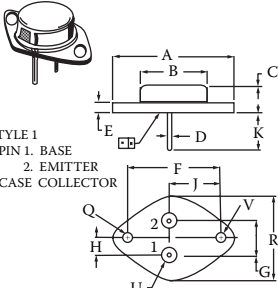
\*MAXIMUM RATINGS

Rating	Symbol	2N6546	2N6547	UNIT
Collector-emitter voltage	V <sub>CEO(sus)</sub>	300	400	V <sub>dc</sub>
Collector-emitter voltage	V <sub>CEX(sus)</sub>	350	450	V <sub>dc</sub>
Collector-emitter voltage	V <sub>CEV</sub>	650	850	V <sub>dc</sub>
Collector base voltage	V <sub>EB</sub>	9.0		V <sub>dc</sub>
Collector current – Continuous	I <sub>C</sub>	15		Adc
– Peak (1)	I <sub>CM</sub>	30		Adc
Base current – Continuous	I <sub>B</sub>	10		Adc
– Peak (1)	I <sub>BM</sub>	20		Adc
Emitter current – Continuous	I <sub>E</sub>	25		Adc
– Peak (1)	I <sub>EM</sub>	50		Adc
Total power dissipation @ T <sub>C</sub> = 25°C	P <sub>D</sub>	175		Watts
@ T <sub>C</sub> = 100°C		100		W/°C
Derate above 25°C		1.0		W/°C
Operating and storage junction Temperature range	T <sub>J</sub> , T <sub>stg</sub>	-65 to +200		°C

**THERMAL CHARACTERISTICS**

characteristic	Symbol	Max	Unit
Thermal resistance, junction to case	R <sub>θJC</sub>	1.0	°C/W
Maximum lead temperature for soldering Purposes: 1/8" from case for 5 Seconds	T <sub>L</sub>	275	°C

\*Indicates JEDEC registered data  
(1) Pulse test: Pulse width = 5.0 ms, Duty cycle ≤ 10%



STYLE 1  
PIN 1. BASE  
2. EMITTER  
CASE COLLECTOR

NOTES:  
1 Dimensions Q and V are datums  
2 [T] is seating plane and datum  
3 Positional tolerance for mounting hole Q

[?]	[?]	[?]	[?]	[?]	[?]	[?]	[?]
[?]	[?]	[?]	[?]	[?]	[?]	[?]	[?]

4 Dimensions and tolerances per ansi y14.5. 1973

Dim	Millimeters		Inches	
	Min	Max	Min	Max
A	-	39.37	-	1.550
B	-	21.08	-	0.830
C	6.35	7.62	0.250	0.300
D	0.97	1.09	0.038	0.043
E	1.40	1.78	0.055	0.070
F	30.15	BSC	1.187	BSC
G	10.92	BSC	0.430	BSC
H	5.46	BSC	0.215	BSC
J	16.89	BSC	0.665	BSC
K	11.18	T2.19	0.440	0.480
U	3.81	4.19	0.150	0.165
R	-	26.67	-	1.050
V	4.83	5.33	0.190	0.210
V	3.81	4.19	0.150	0.165

CASE 1-05  
TO-204AA

FIGURE 8.6 Data sheet for transistor 2N6546. (Courtesy of Motorola, Inc.)

$$I_C = I_s (e^{V_{BE}/nV_T} - 1)$$

$$2 = I_s (e^{0.8/(25.8 \times 10^{-3})} - 1)$$
(8.1)

which gives  $I_s = 2.33E-27$  A. DC current gain at 10 A is  $h_{FE} = 6$  to 30. Taking the geometric mean gives  $BF = BR = \sqrt{6 \times 30} \approx 13$ .

\*ELECTRICAL CHARACTERISTICS (T<sub>C</sub> = 25°C unless otherwise noted.)

Characteristic	Symbol	Min	Max	Unit	
<b>OFF CHARACTERISTICS (1)</b>					
Collector-Emitter sustaining voltage (I <sub>C</sub> = 100 mA, I <sub>B</sub> = 0)	2N6546 2N6547 V <sub>CEO(sus)</sub>	300 400	— —	Vdc	
Collector-Emitter sustaining voltage (I <sub>C</sub> = 8.0 A, V <sub>clamp</sub> = Rated V <sub>CEX</sub> , T <sub>C</sub> = 100°C)	2N6546 2N6547 V <sub>CEX(sus)</sub>	350 450	— —	Vdc	
(I <sub>C</sub> = 15 A, V <sub>clamp</sub> = Rated V <sub>CEO</sub> - 100 V, T <sub>C</sub> = 100°C)	2N6546 2N6547	200 300	— —		
Collector cutoff current (V <sub>CEV</sub> = Rated value, V <sub>BE(off)</sub> = 1.5 Vdc) (V <sub>CEV</sub> = Rated value, V <sub>BE(off)</sub> = 1.5 Vdc, T <sub>C</sub> = 100°C)	I <sub>CEV</sub>	— —	1.0 4.0	mAdc	
Collector cutoff current (V <sub>CE</sub> = Rated V <sub>CEV</sub> , R <sub>BE</sub> = 50 Ω, T <sub>C</sub> = 100°C)	I <sub>CER</sub>	—	5.0	mAdc	
Emitter cutoff current (V <sub>EB</sub> = 9.0 Vdc, I <sub>C</sub> = 0)	I <sub>EBO</sub>	—	1.0	mAdc	
<b>SECOND BREAKDOWN</b>					
Second breakdown collector current with base forward biased t = 1.0 s (non-repetitive) (V <sub>CE</sub> = 100 Vdc)	I <sub>S/b</sub>	0.2	—	Adc	
<b>ON CHARACTERISTICS (1)</b>					
DC current gain (I <sub>C</sub> = 5.0 Adc, V <sub>CE</sub> = 2.0 Vdc) (I <sub>C</sub> = 10 Adc, V <sub>CE</sub> = 2.0 Vdc)	h <sub>FE</sub>	12 6.0	60 30	—	
Collector-Emitter saturation voltage (I <sub>C</sub> = 10 Adc, I <sub>B</sub> = 2.0 Adc) (I <sub>C</sub> = 15 Adc, I <sub>B</sub> = 3.0 Adc) (I <sub>C</sub> = 10 Adc, I <sub>B</sub> = 2.0 Adc, T <sub>C</sub> = 100°C)	V <sub>CE(sat)</sub>	— — —	1.5 5.0 2.5	Vdc	
Base-Emitter saturation voltage (I <sub>C</sub> = 10 Adc, I <sub>B</sub> = 2.0 Adc) (I <sub>C</sub> = 10 Adc, I <sub>B</sub> = 2.0 Adc, T <sub>C</sub> = 100°C)	V <sub>BE(sat)</sub>	— —	1.6 1.6	Vdc	
<b>DYNAMIC CHARACTERISTICS</b>					
Current-gain – Bandwidth product (I <sub>C</sub> = 500 mAdc, V <sub>CE</sub> = 10 Vdc, f <sub>test</sub> = 1.0 MHz)	f <sub>T</sub>	6.0	28	MHz	
Output capacitance (V <sub>CB</sub> = 10 Vdc, I <sub>E</sub> = 0, f <sub>test</sub> = 1.0 MHz)	C <sub>ob</sub>	125	500	pF	
<b>SWITCHING CHARACTERISTICS</b>					
<b>Resistive load</b>					
Delay time	(V <sub>CC</sub> = 250 V, I <sub>C</sub> = 10 A,	t <sub>d</sub>	—	0.05	μs
Rise time	I <sub>B1</sub> = I <sub>B2</sub> = 2.0 A, t <sub>p</sub> = 100 μs,	t <sub>r</sub>	—	1.0	μs
Storage time	Duty cycle ≤ 2.0%)	t <sub>s</sub>	—	4.0	μs
Fall time		t <sub>f</sub>	—	0.7	μs
<b>Inductive load, Clamped</b>					
Storage time	(I <sub>C</sub> = 10 A(pk), V <sub>clamp</sub> = Rated V <sub>CEX</sub> , I <sub>B1</sub> = 2.0 A,	t <sub>s</sub>	—	5.0	μs
Fall time	V <sub>BE(off)</sub> = 5.0 Vdc, T <sub>C</sub> = 100°C)	t <sub>f</sub>	—	1.5	μs
<b>Typical</b>					
Storage time	(I <sub>C</sub> = 10 A(pk), V <sub>clamp</sub> = Rated V <sub>CEX</sub> , I <sub>B1</sub> = 2.0 A,	t <sub>s</sub>	2.0	μs	
Fall time	V <sub>BE(off)</sub> = 5.0 Vdc, T <sub>C</sub> = 25°C)	t <sub>f</sub>	0.09	μs	

\*Indicates JEDEC registered data  
(1) Pulse test: Pulse width = 300 μs, Duty cycle = 2%.

FIGURE 8.6 (continued).

The input capacitance at the base-emitter junction is very small, and its typical value is 0.2 – 1 pF. Let us assume that C<sub>je</sub> = CJE = 1 pF. Output capacitance, C<sub>obo</sub> = 125 – 500 pF at V<sub>CB</sub> = 10 V, I<sub>E</sub> = 0 (reverse biased). Taking the geometric mean gives C<sub>obo</sub> = C<sub>μ</sub> = √(125 × 500) ≈ 250 pF. C<sub>μo</sub> can be found from

$$C_{\mu} = \frac{C_{\mu o}}{(1 + V_{CB}/V_0)^m} \tag{8.2}$$

TYPICAL ELECTRICAL CHARACTERISTICS

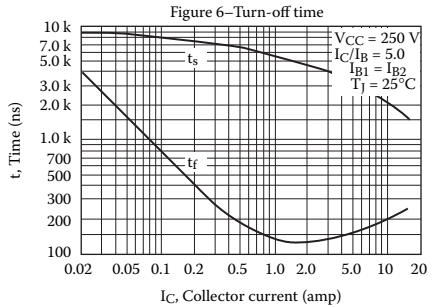
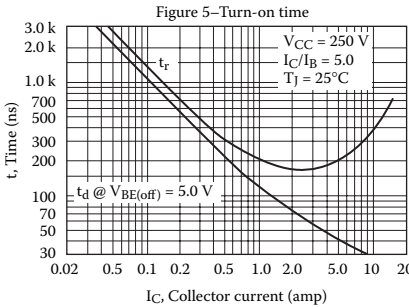
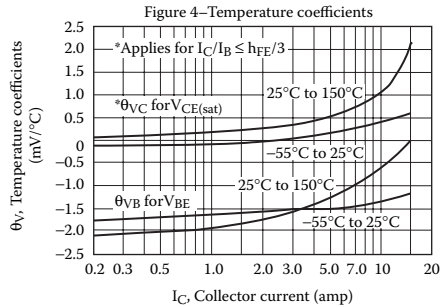
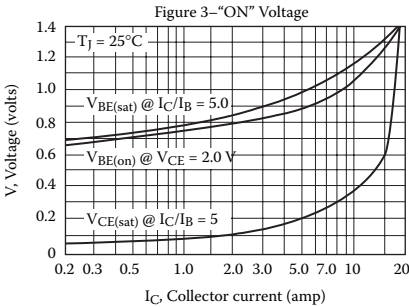
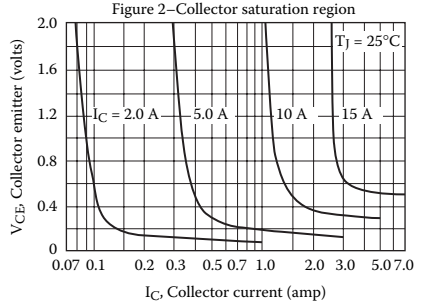
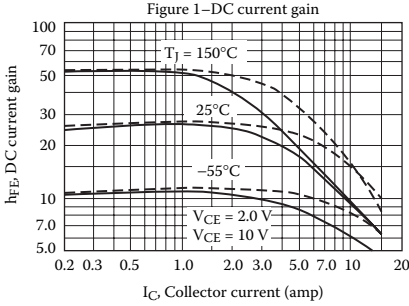
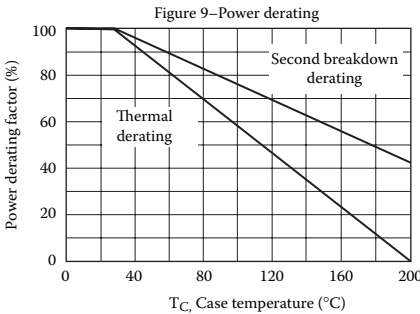
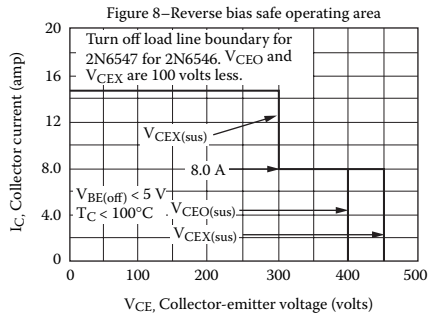
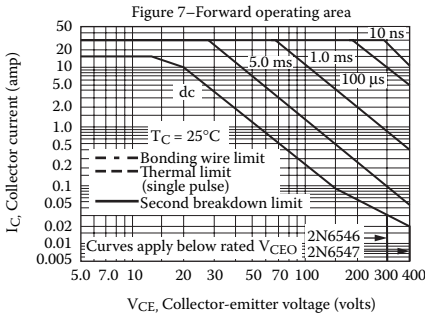


FIGURE 8.6 (continued).

where  $m = \frac{1}{3}$  and  $V_0 = 0.75\text{ V}$ . From Equation 8.2,  $C_{\mu o} = CJC = 607.3\text{ pF}$  at  $V_{CB} = 10\text{ V}$ .

The transition frequency  $f_{T(\min)} = 6\text{ MHz}$  at  $V_{CE} = 10\text{ V}$ ,  $I_C = 500\text{ mA}$ . The transition period is  $\tau_T = 1/2\pi f_T = 1/(2\pi \times 6\text{ MHz}) = 26,525.8\text{ psec}$ . Thus  $V_{CB} \approx V_{CE} - V_{BE} = 10 - 0.7 = 9.3\text{ V}$ , and Equation 8.2 gives  $C_{\mu} = 255.7\text{ pF}$ . The transconductance  $g_m$  is



There are two limitations on the power handling ability of a transistor: Average junction temperature and second breakdown. Safe operating area curves indicate  $I_C$ - $V_{CE}$  limits of the transistor that must not be subjected to greater dissipation than the curves indicate.

The data of figure 7 is based on  $T_C = 25^\circ\text{C}$ ;  $T_{j(pk)}$  is variable depending on power level. Second breakdown pulse limits are valid for duty cycles to 10% but must be derated when  $T_C \geq 25^\circ\text{C}$ . Second breakdown limitations do not derate the same as thermal limitations. Allowable current at the voltages shown on figure 7 may be found at any case temperature by using the appropriate curve on figure 9.

$T_{j(pk)}$  may be calculated from the data in figure 10. At high case temperatures, thermal limitations will reduce the power that can be handled to values less than the limitations imposed by second breakdown.

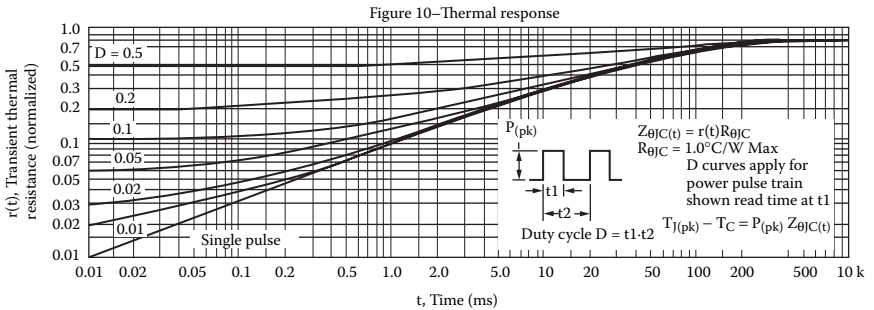


FIGURE 8.6 (continued).

$$g_m = \frac{I_C}{V_T} = \frac{500 \text{ mA}}{25.8 \text{ mV}} = 19.38 \text{ A/V} \tag{8.3}$$

The transition period  $\tau_T$  is related to forward transit time  $\tau_F$  by

$$\tau_T = \tau_F + \frac{C_{je}}{g_m} + \frac{C_\diamond}{g_m}$$

or

$$26,525.8 \text{ psec} = \tau_F + \frac{1 \text{ pF}}{19.38} + \frac{255.7 \text{ pF}}{19.38} \quad (8.4)$$

which gives  $\tau_F = 26,512.6$  psec. Thus, the PSpice model statement for transistor 2N6546 is

```
.MODEL 2N6546 NPN (IS=6.83E-14 BF=13 CJE=1
PF CJC=607.3PF TF=26.5NS)
```

This model can be used to plot the characteristics of the MOSFET. It may be necessary to modify the parameter values to conform to the actual characteristics.

*Note:* It is often necessary to adjust the base resistance  $R_B$  or base (control) voltage  $V_g$  so that the transistor is driven into saturation.

## 8.5 EXAMPLES OF BJT CHOPPERS

The applications of the SPICE BJT model are illustrated by some examples.

### EXAMPLE 8.2 FINDING THE PERFORMANCE OF A STEP-DOWN DC–DC CONVERTER WITH A BJT SWITCH

A BJT buck chopper is shown in Figure 8.7(a). The DC input voltage is  $V_S = 12$  V. The load resistance  $R$  is  $5 \Omega$ . The filter inductance is  $L = 145.84 \mu\text{H}$ , and the filter capacitance is  $C = 200 \mu\text{F}$ . The chopping frequency is  $f_c = 25$  kHz, and the duty cycle of the chopper is  $k = 42\%$ . The control voltage is shown in Figure 8.7(b). Use PSpice to (a) plot the instantaneous load current  $i_o$ , the input current  $i_s$ , the diode voltage  $v_D$ , and the output voltage  $v_C$  and (b) calculate the Fourier coefficients of the input current  $i_s$ . Plot the frequency response of the converter output voltage from 10 kHz to 10 MHz and find the resonant frequency.

#### SOLUTION

The DC supply voltage  $V_S = 12$  V.  $k = 0.42$ ,  $f_c = 25$  kHz,  $T = 1/f_c = 40 \mu\text{sec}$ , and  $t_{\text{on}} = k \times T = 16.7 \mu\text{sec}$ . An initial value for  $C$  is assigned to reach steady state faster.

The PSpice schematic is shown in Figure 8.8. A voltage-controlled voltage source with a gain of 30 drives the BJT switch. The PWM generator is implemented as a descending hierarchy as shown in Figure 8.3(b). The model parameters for the BJT switch and the freewheeling diode are as follows:

```
.MODEL QMOD NPN (IS=6.83E-14 BF=13 CJE=1pF CJC=607.3PF
TF=26.5NS)
```

```
.MODEL DMD D (IS=2.22E-15 BV=1200V CJO=1PF TT=0US)
```

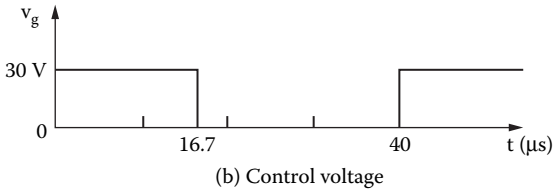
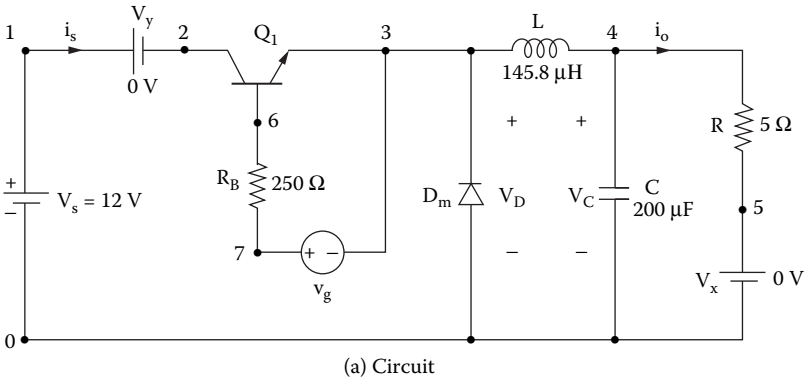
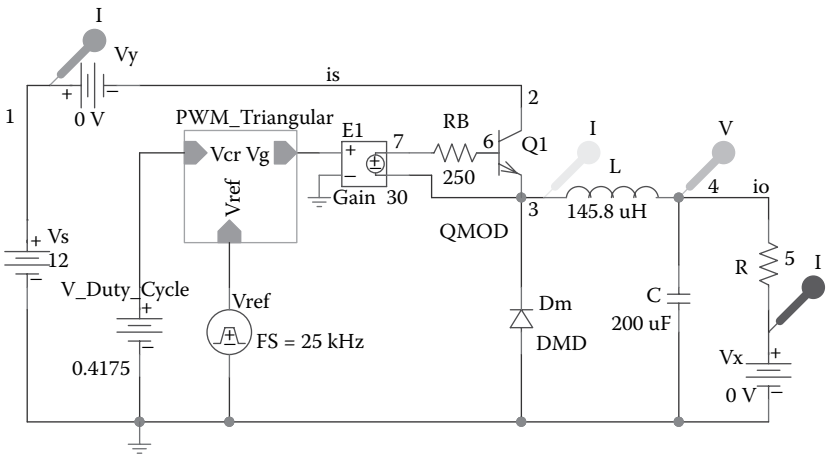


FIGURE 8.7 BJT buck chopper for PSpice simulation. (a) Circuit, (b) control voltage.



The list of the circuit file is as follows:

### Example 8.2 BJT buck chopper

```

SOURCE  ■ VS 1 0 DC 12V
          VY 1 2 DC 0V ; Voltage source to measure input current
          Vg 7 3 PULSE (0V 30V 0 0.1NS 0.1NS 16.7US 40US)
CIRCUIT ■■ RB 7 6 250 ; Transistor base resistance
          R 4 5 5
          L 3 4 145.8UH
          C 4 0 200UF IC=0V ; Initial voltage
          VX 5 0 DC 0V ; To measure load current
          DM 0 3 DMOD ; Freewheeling diode
          .MODEL DMOD D(IS=2.22E-15 BV=1200V CJO=0 TT=0)
          Q1 2 6 3 3 2N6546 ; BJT switch
          .MODEL 2N6546 NPN (IS=6.83E-14 BF=13 CJE=1PF
          CJC=607.3PF TF=26.5NS)
ANALYSIS ■■■ .TRAN 0.1US 2.1MS 2MS UIC ; Transient analysis
          .PROBE ; Graphics post-processor
          .OPTIONS ABSTOL = 1.00N RELTOL = 0.01 VNTOL = 0.1
          ITL5 = 40000
          .FOUR 25KHZ I(VY) ; Fourier analysis
          .END
  
```

Note the following:

- The PSpice plots of the instantaneous load current  $I(VX)$ , the input current  $I(VY)$ , the diode voltage  $V(3)$ , and the output voltage  $V(5)$  are shown in [Figure 8.9\(a\)](#).
- The Fourier coefficients of the input current are:

### FOURIER COMPONENTS OF TRANSIENT RESPONSE $I(VY)$

DC COMPONENT = 3.938953E-01

Harmonic No	Frequency (Hz)	Fourier Component	Normalized Component	Phase (Deg)	Normalized Phase (Deg)
1	2.500E+04	5.919E-01	1.000E+00	1.792E+02	0.000E+00
2	5.000E+04	2.021E-01	3.415E-01	-1.106E+02	-2.898E+02
3	7.500E+04	1.545E-01	2.611E-01	-1.260E+02	-3.053E+02
4	1.000E+05	1.299E-01	2.195E-01	-6.211E+01	-2.413E+02
5	1.250E+05	6.035E-02	1.020E-01	-6.698E+01	-2.462E+02
6	1.500E+05	9.647E-02	1.630E-01	-2.055E+01	-1.998E+02
7	1.750E+05	4.065E-02	6.869E-02	1.750E+01	-1.617E+02
8	2.000E+05	6.771E-02	1.144E-01	1.779E+01	-1.614E+02
9	2.250E+05	4.600E-02	7.772E-02	7.940E+01	-9.984E+01

TOTAL HARMONIC DISTORTION = 5.420088E+01 PERCENT

Figure 8.9(b) gives the resonant frequency of  $f_{\text{res}} = 872.15$  Hz at a resonant peak gain of  $A_{\text{o(peak)}} = 3.16$ .

*Note:* The base resistance RB is needed to limit the base drive current of the BJT switch. The LC output filter is needed to reduce the ripples on the load voltage and current. For a duty cycle of  $k = 0.42$ , the average voltage at the output of the converter [1] is  $V_{\text{o(av)}} = kV_s = 0.42 \times 12 = 5.04$  V.

### EXAMPLE 8.3 FINDING THE PERFORMANCE OF A BUCK–BOOST DC–DC CONVERTER WITH A BJT SWITCH

A BJT buck–boost chopper is shown in Figure 8.10(a). The DC input voltage is  $V_s = 12$  V. The load resistance  $R$  is  $5 \Omega$ . The inductance is  $L = 150 \mu\text{H}$ , and the filter capacitance is  $C = 200 \mu\text{F}$ . The chopping frequency is  $f_c = 25$  kHz, and the duty cycle of the chopper is  $k = 25\%$ . The control voltage is shown in Figure 8.10(b). Use PSpice to plot the instantaneous output voltage  $v_o$ , the capacitor current  $i_c$ , the inductor current  $i_L$ , and the inductor voltage  $v_L$ . Plot the frequency response of the converter output voltage from 100 kHz to 10 MHz and find the resonant frequency.

#### SOLUTION

The DC supply voltage  $V_s = 12$  V,  $k = 0.25$ ,  $f_c = 25$  kHz,  $T = 1/f_c = 40 \mu\text{sec}$ , and  $t_{\text{on}} = k \times T = 0.25 \times 40 = 10 \mu\text{sec}$ .

The PSpice schematic is shown in Figure 8.11. A voltage-controlled voltage source with a gain of 40 drives the BJT switch. The PWM generator is implemented as a descending hierarchy as shown in Figure 8.3(b). The model parameters for the BJT switch and the freewheeling diode are as follows:

```
.MODEL QMOD NPN(IS=6.83E-14 BF=13 CJE=1pF CJC=607.3PF
TF=26.5NS)
.MODEL DMD D(IS=2.22E-15 BV=1200V CJO=1PF TT=0US))
```

The list of the circuit file is as follows:

---

### Example 8.3 BJT buck–boost chopper

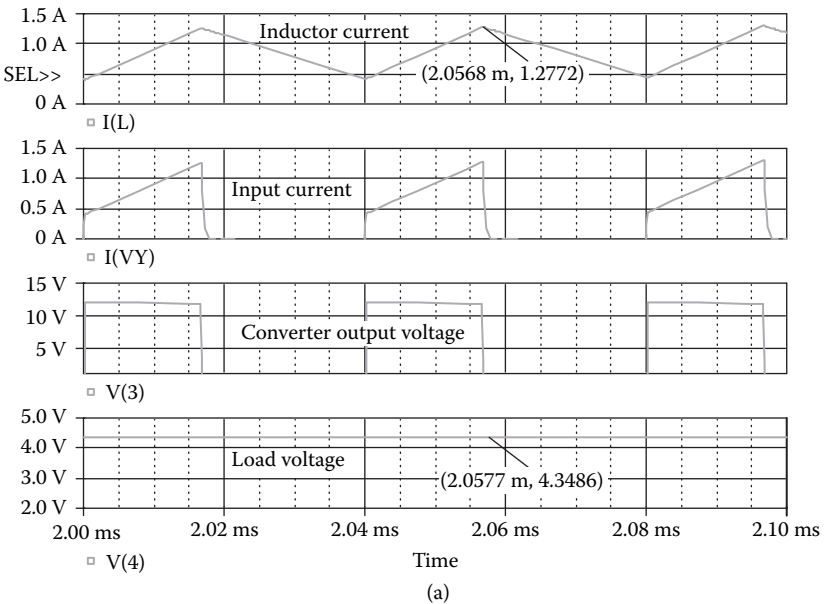
```
SOURCE  ■ VS 1 0 DC 12V
          VY 1 2 DC 0V ; Voltage source to measure input current
          Vg 7 3 PULSE (0V 40V 0 0.1NS 0.1NS 10US 40US)
CIRCUIT  ■■ RB 7 6 250 ; Transistor base resistance
          R 5 0 5
          L 3 0 150UH
          C 5 0 200UF IC=0V ; Initial voltage on capacitor
          VX 3 4 DC 0V ; Voltage source to measure diode current
          DM 5 4 DMOD ; Freewheeling diode
```

```
.MODEL DMOD D(IS=2.22E-15 BV=1200V IBV=13E-3 CJO=0 TT=0)
; Diode model
Q1 2 6 3 3 2N6546 ; BJT switch
.MODEL 2N6546 NPN (IS=6.83E-14 BF=13 CJE=1PF
CJC=607.3PF TF=26.5NS)
ANALYSIS ■■■ .TRAN 0.1US 1MS 750US UIC ; Transient analysis
.PROBE ; Graphics post-processor
.OPTIONS ABSTOL = 1.00N RELTOL = 0.01 VNTOL = 0.1
ITL5 = 40000
.FOUR 25KHZ I(VY) ;Fourier analysis
.END
```

The PSpice plots of the instantaneous output voltage V(5), the capacitor current I(C), the inductor current I(L), and the inductor voltage V(3) are shown in [Figure 8.12\(a\)](#).

[Figure 8.12\(b\)](#) gives the resonant frequency of  $f_{res} = 872.15$  Hz at a resonant peak gain of  $A_{o(peak)} = 3.2$ .

*Note:* The base drive voltage is increased to 40 V in order to reduce distortion on the switch voltage and the converter output voltage. The output voltage is negative. For a duty cycle of  $k = 0.25$ , the average load voltage is  $V_{o(av)} = kV_s/(1 - k) = 0.25 \times 12/(1 - 0.25) = 4$  V (PSpice gives 3.5 V). The load voltage has not yet reached the steady-state value.



**FIGURE 8.9** Plots for Example 8.2. (a) Transient plots, (b) Frequency response.

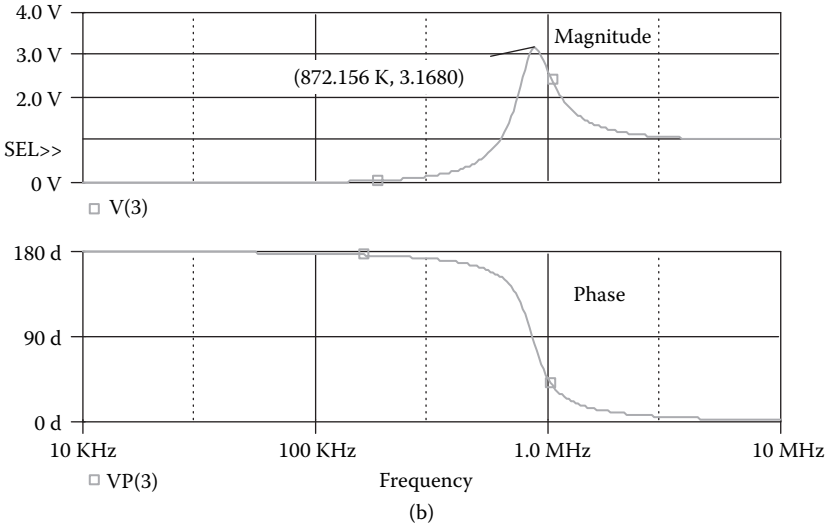


FIGURE 8.9 (continued).

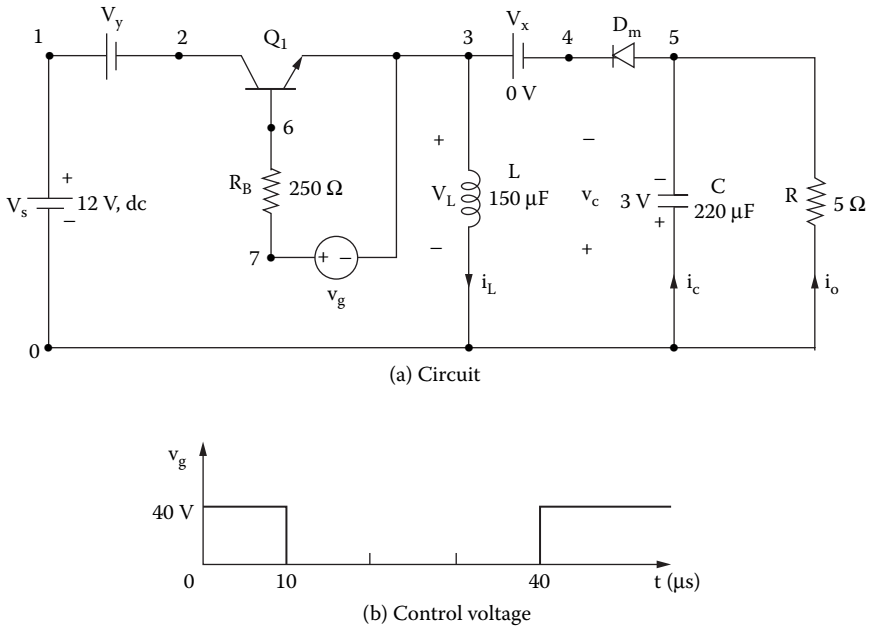


FIGURE 8.10 BJT buck-boost chopper for PSpice simulation. (a) Circuit, (b) control voltage.

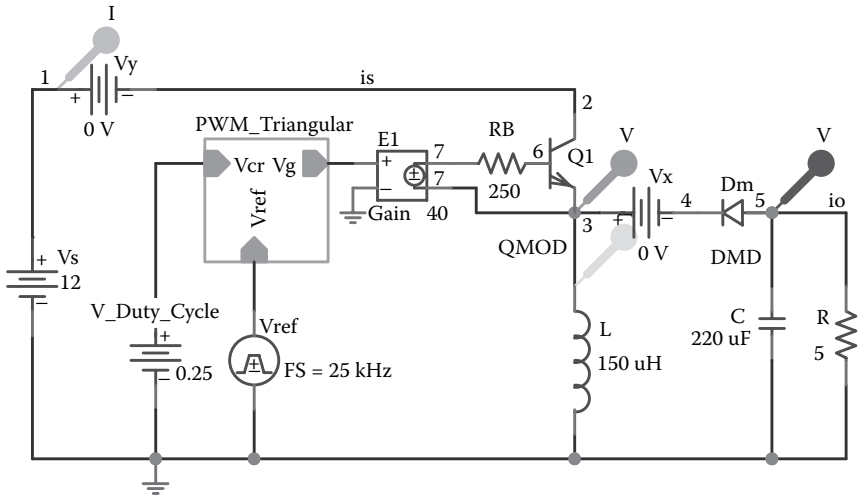


FIGURE 8.11 PSpice schematic for Example 8.3.

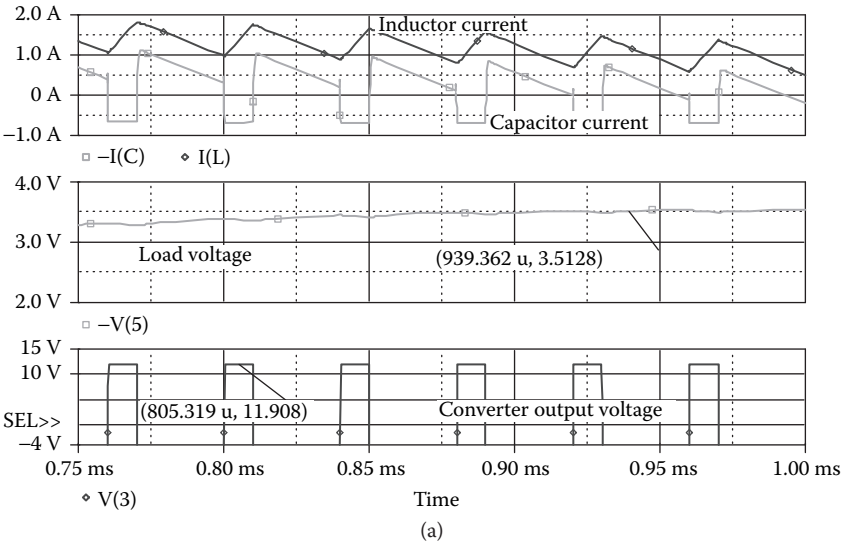


FIGURE 8.12 Plots for Example 8.3. (a) Transient plots, (b) Frequency response.

**EXAMPLE 8.4 FINDING THE PERFORMANCE OF CUK DC-DC CONVERTER WITH A BJT SWITCH**

A BJT cuk chopper is shown in Figure 8.13(a). The DC input voltage is  $V_s = 12$  V. The load resistance  $R$  is  $5 \Omega$ . The inductances are  $L_1 = 200 \mu\text{H}$  and  $L_2 = 150 \mu\text{H}$ . The capacitance are  $C_1 = 200 \mu\text{F}$  and  $C_2 = 220 \mu\text{F}$ . The chopping frequency is  $f_c = 25$  kHz, and the duty cycle of the chopper is  $k = 25\%$ . The control voltage is shown

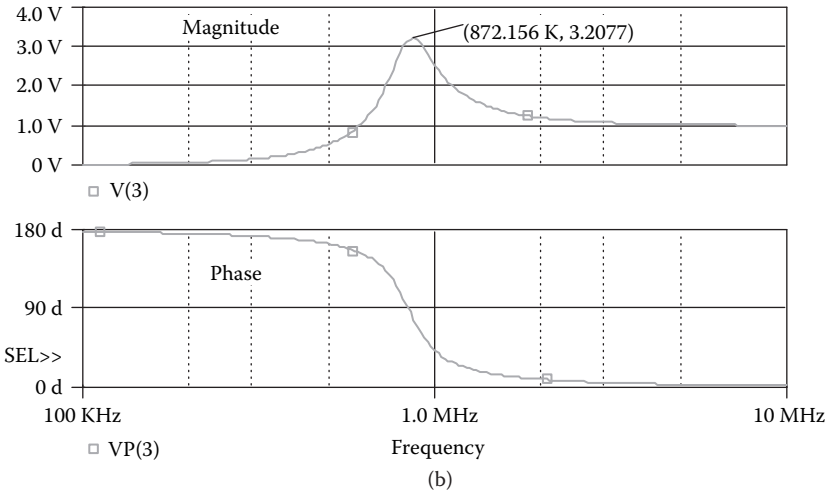


FIGURE 8.12 (continued).

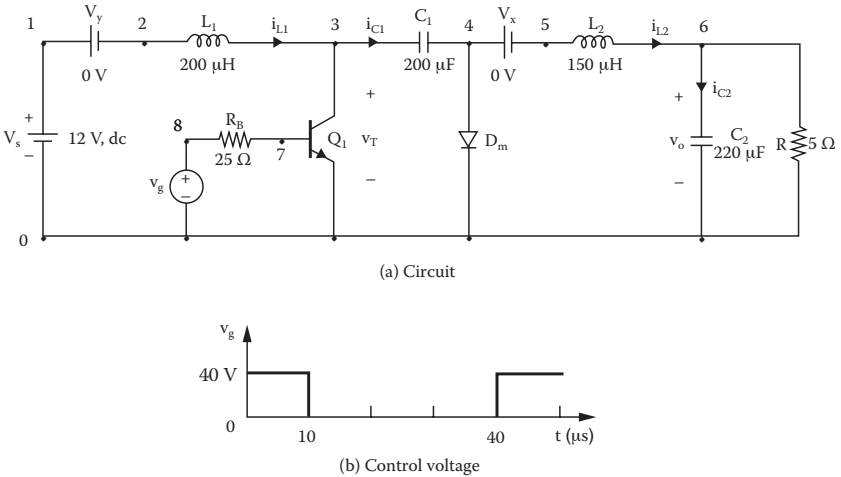


FIGURE 8.13 BJT cuk chopper for PSpice simulation. (a) Circuit, (b) control voltage.

in Figure 8.13(b). Use PSpice to plot the instantaneous capacitor current  $i_{C1}$ , the capacitor current  $i_{C2}$ , the inductor current  $i_{L1}$ , the inductor current  $i_{L2}$ , and the transistor voltage  $v_T$ . Plot the frequency response of the converter output voltage from 100 Hz to 4 kHz and find the resonant frequency.

The PSpice schematic is shown in Figure 8.14. A voltage-controlled voltage source with a gain of 30 drives the BJT switch. The PWM generator is implemented as a descending hierarchy as shown in Figure 8.3(b). The model parameters for the BJT switch and the freewheeling diode are as follows:

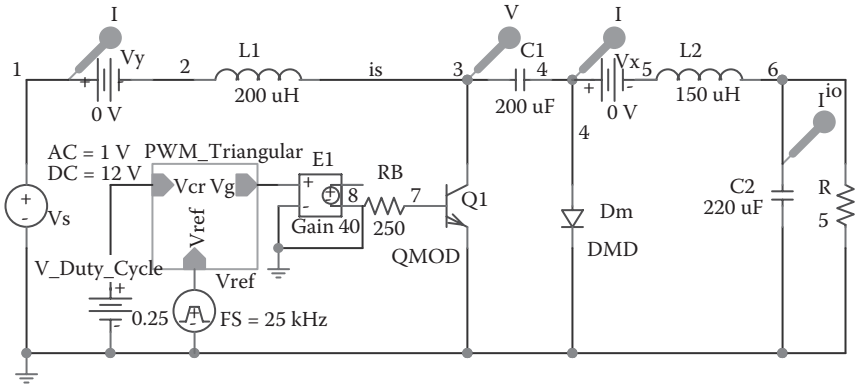


FIGURE 8.14 PSpice schematic for Example 8.4.

```
.MODEL QMOD NPN(IS=6.83E-14 BF=13 CJE=1pF CJC=607.3PF
TF=26.5NS)
.MODEL DMD D(IS=2.22E-15 BV=1200V CJO=1PF TT=0US))
```

**SOLUTION**

The DC supply voltage  $V_S = 12\text{ V}$ . An initial capacitor voltage  $V_C = 3\text{ V}$ ,  $k = 0.25$ ,  $f_c = 25\text{ kHz}$ ,  $T = 1/f_c = 40\text{ }\mu\text{sec}$ , and  $t_{on} = k \times T = 0.25 \times 40 = 10\text{ }\mu\text{sec}$ . The list of the circuit file is as follows:

**Example 8.4 BJT cuk chopper**

```
SOURCE ■ VS 1 0 DC 12V
          VY 1 2 DC 0V ; Voltage source to measure input current
          Vg 8 0 PULSE (0V 40V 0 0.1NS 0.1NS 10US 40US)
CIRCUIT ■■ RB 8 7 25 ; Transistor base resistance
            R 6 0 5
            L1 2 3 200UH
            C1 3 4 200UF
            L2 5 6 150UF
            C2 6 0 220UF IC=0V ; Initial conditions
            VX 4 5 DC ; Voltage source to measure current of L2
            DM 4 0 DMOD
            .MODEL DMOD D(IS=2.22E-15 BV=1200V IBV=13E-3 CJO=0
            TT=0) ; Diode model
            Q1 3 7 0 2N6546 ; BJT switch
            .MODEL 2N6546 NPN (IS=6.83E-14 BF=13 CJE=1PF
            CJC=607.3PF TF=26.5NS)
```

```

ANALYSIS ■■■ .TRAN 0.1US 1MS 600US 750US ; Transient analysis
               .PROBE                               ; Graphics post-processor
               .OPTIONS ABSTOL = 1.00N RELTOL = 0.01 VNTOL = 0.1
               ITL5 = 40000
               .FOUR 25KHZ I(VY)                   ; Fourier analysis
               .END

```

The PSpice plots of the instantaneous capacitor current  $I(C1)$ , the capacitor current  $I(C2)$ , the inductor current  $I(L1)$ , the inductor current  $I(L2)$ , and the transistor voltage  $V(3)$  are shown in [Figure 8.15\(a\)](#). The output voltage has not reached steady state.

Figure 8.15(b) gives the resonant frequency of  $f_{\text{res}} = 833.28$  Hz at a resonant peak gain of  $A_{\text{o(peak)}} = 6.8$ .

*Note:* The base drive voltage is increased to 40 V in order to reduce distortion on the switch voltage and the converter output voltage. The output voltage is negative. For a duty cycle of  $k = 0.25$ , the average load voltage is  $V_{\text{o(av)}} = kV_s/(1-k) = 0.25 \times 12/(1-0.25) = 4$  V (PSpice gives 3.5 V). The load voltage has not yet reached the steady-state value. If we run the simulation for a longer time as shown in [Figure 8.15](#), we can find out the oscillation of the converter output voltage at its natural frequency.

## 8.6 MOSFET CHOPPERS

The PSpice model of an  $n$ -channel MOSFET [4–6] is shown in [Figure 8.17\(a\)](#). The static (DC) model that is generated by PSpice is shown in [Figure 8.17\(b\)](#). The model parameters for a MOSFET device and the default values assigned by PSpice are given in [Table 8.2](#). The model equations of MOSFETs that are used by PSpice are described in Reference 4 and Reference 6.

The model statement of  $n$ -channel MOSFETs has the general form

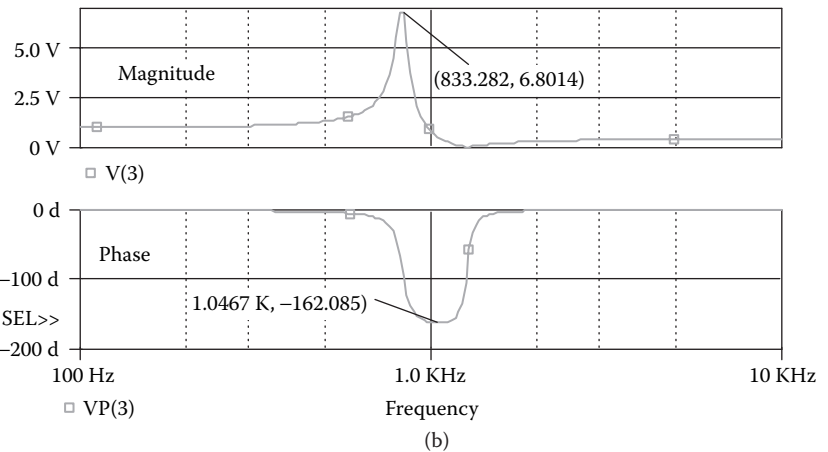
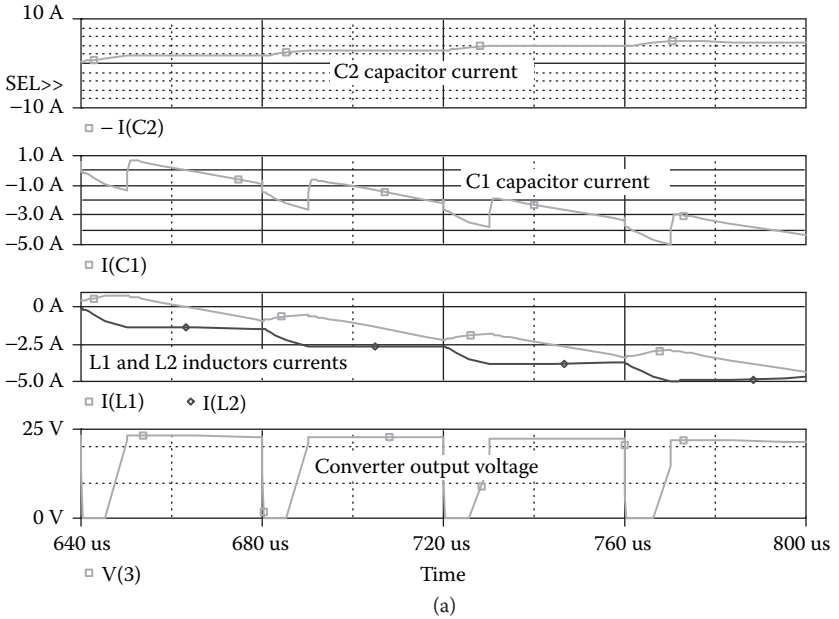
```
.MODEL MNAME NMOS (P1=V1 P2=V2 P3=V3 ... PN=VN)
```

and the statement for  $p$ -channel MOSFETs has the form

```
.MODEL MNAME PMOS (P1=V1 P2=V2 P3=V3 ... PN=VN)
```

where MNAME is the model name. It can begin with any character, and its word size is normally limited to eight characters. NMOS and PMOS are the type symbols of  $n$ -channel and  $p$ -channel MOSFETs, respectively. P1, P2, ... and V1, V2, ... are the parameters and their values, respectively.

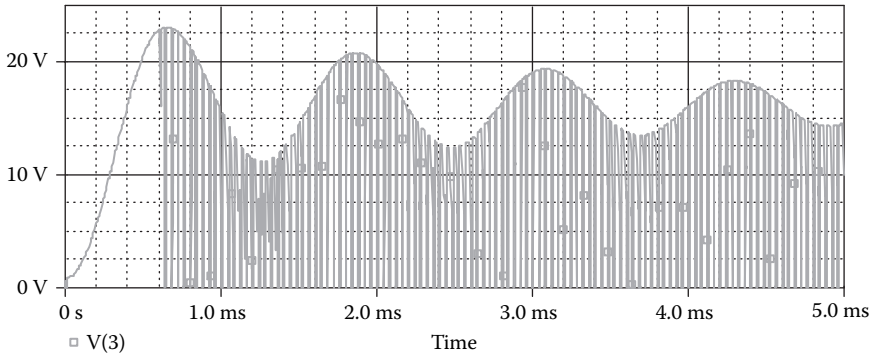
L and W are the channel length and width, respectively. AD and AS are the drain and source diffusion areas. L is decreased by twice LD to get the effective channel length. W is decreased by twice WD to get the effective channel width. L and W can be specified on the device, the model, or on the .OPTION statement.



**FIGURE 8.15** Plots for Example 8.4. (a) Transient plots, (b) frequency response.

The value on the device supersedes the value on the model, which supersedes the value on the .OPTION statement.

AD and AS are the drain and source diffusion areas. PD and PS are the drain and source diffusion perimeters. The drain-bulk and source-bulk saturation currents can be specified either by JS, which is multiplied by AD and AS, or by IS, which is an absolute value. The zero-bias depletion capacitance can be specified by CJ, which is multiplied by AD and AS, and by CJSW, which is multiplied by



**FIGURE 8.16**

PD and PS. Alternatively, these capacitances can be set by CBD and CBS, which are absolute values.

A MOSFET is modeled as an intrinsic MOSFET with ohmic resistances in series with the drain, source, gate, and bulk (substrate). There is also a shunt resistance (RDS) in parallel with the drain–source channel. NRD, NRS, NRG, and NRB are the relative resistivities of the drain, source, gate, and substrate in squares. These parasitic (ohmic) resistances can be specified by RSH, which is multiplied by NRD, NRS, NRG, and NRB, respectively; or, alternatively, the absolute values of RD, RS, RG, and RB can be specified directly.

PD and PS default to 0, NRD and NRS default to 1, and NRG and NRB default to 0. Defaults for L, W, AD, and AS may be set in the .OPTIONS statement. If AD or AS defaults are not set, they also default to 0. If L or W defaults are not set, they default to 100  $\mu\text{m}$ .

The DC characteristics are defined by parameters VTO, KP, LAMBDA, PHI, and GAMMA, which are computed by PSpice using the fabrication-process parameters NSUB, TOX, NSS, NFS, TPG, and so on. The values of VTO, KP, LAMDA, PHI, and GAMMA, which are specified on the model statement, supersede the values calculated by PSpice based on fabrication-process parameters. VTO is positive for enhancement-type *n*-channel MOSFETs and for depletion-type *p*-channel MOSFETs. VTO is negative for enhancement-type *p*-channel MOSFETs and for depletion-type *n*-channel MOSFETs.

PSpice incorporates three MOSFET device models. The LEVEL parameter selects between different models for the intrinsic MOSFET. If LEVEL = 1, the Shichman–Hodges model [5] is used. If LEVEL = 2, an advanced version of the Shichman–Hodges model, which is a geometry-based analytical model and incorporates extensive second-order effects [6], is used. If LEVEL = 3, a modified version of the Shichman–Hodges model, which is a semiempirical short-channel model [7], is used.

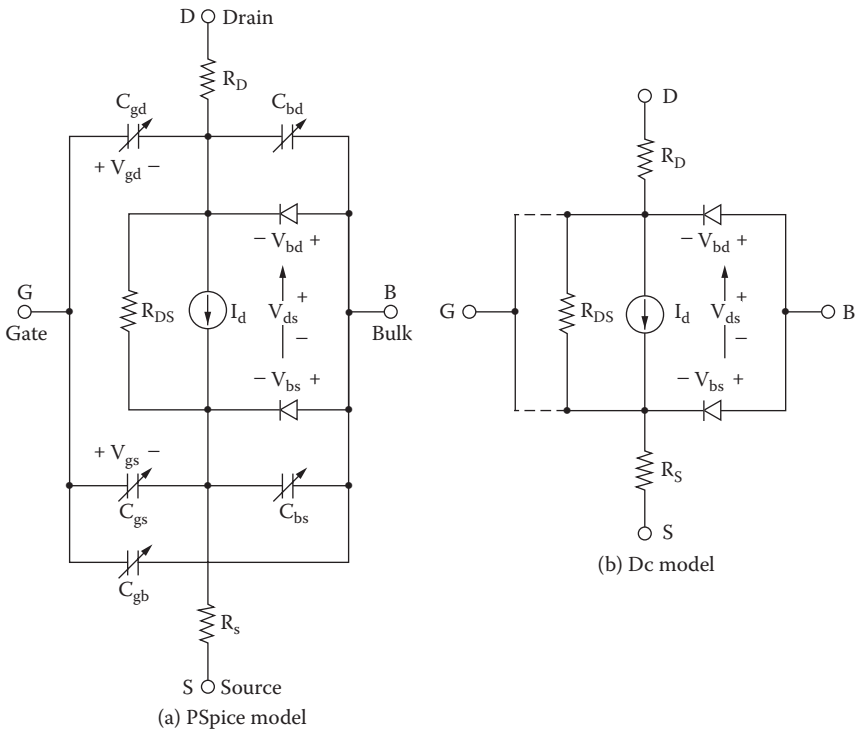
The LEVEL-1 model, which employs fewer fitting parameters, gives approximate results. However, it is useful for a quick, rough estimate of circuit performance and is normally adequate for the analysis of power electronics circuits.

**TABLE 8.2**  
**Model Parameters of MOSFETs**

Name	Model Parameter	Unit	Default	Typical
LEVEL	Model type (1, 2, or 3)		1	
L	Channel length	m	DEFL	
W	Channel width	m	DEFW	
LD	Lateral diffusion (length)	m	0	
WD	Lateral diffusion (width)	m	0	
VTO	Zero-bias threshold voltage	V	0	0.1
KP	Transconductance	A/V <sup>2</sup>	2E-5	2.5E-5
GAMMA	Bulk threshold parameter	V <sup>1/2</sup>	0	0.35
PHI	Surface potential	V	0.6	0.65
LAMBDA	Channel-length modulation (LEVEL = 1 or 2)	V <sup>-1</sup>	0	0.02
RD	Drain ohmic resistance	W	0	10
RS	Source ohmic resistance	W	0	10
RG	Gate ohmic resistance	W	0	1
RB	Bulk ohmic resistance	W	0	1
RDS	Drain-source shunt resistance	W	•	
RSH	Drain-source diffusion sheet resistance	Ω/square	0	20
IS	Bulk <i>p-n</i> saturation current	A	1E-14	1E-15
JS	Bulk <i>p-n</i> saturation current/area	A/m <sup>2</sup>	0	1E-8
PB	Bulk <i>p-n</i> potential	V	0.8	0.75
CBD	Bulk-drain zero-bias <i>p-n</i> capacitance	F	0	5PF
CBS	Bulk-source zero-bias <i>p-n</i> capacitance	F	0	2PF
CJ	Bulk <i>p-n</i> zero-bias bottom capacitance/length	F/m <sup>2</sup>	0	
CJSW	Bulk <i>p-n</i> zero-bias perimeter capacitance/length	F/m	0	
MJ	Bulk <i>p-n</i> bottom grading coefficient		0.5	
MJSW	Bulk <i>p-n</i> sidewall grading coefficient		0.33	
FC	Bulk <i>p-n</i> forward-bias capacitance coefficient		0.5	
CGSO	Gate-source overlap capacitance/channel width	F/m	0	
CGDO	Gate-drain overlap capacitance/channel width	F/m	0	
CGBO	Gate-bulk overlap capacitance/channel length	F/m	0	
NSUB	Substrate doping density	1/cm <sup>3</sup>	0	
NSS	Surface state density	1/cm <sup>2</sup>	0	
NFS	Fast surface state density	1/cm <sup>2</sup>	0	
TOX	Oxide thickness	m	•	
TPG	Gate material type: +1 = opposite of substrate - 1 = same as substrate 0 = aluminum		+1	
XJ	Metallurgical junction depth	m	0	
UO	Surface mobility	cm <sup>2</sup> /V · sec	600	
UCRIT	Mobility degradation critical field (LEVEL = 2)	V/cm	1E4	
UEXP	Mobility degradation exponent (LEVEL = 2)		0	
UTRA	(not used) Mobility degradation transverse field coefficient			
VMAX	Maximum drift velocity	m/sec	0	
NEFF	Channel charge coefficient (LEVEL = 2)		1	

**TABLE 8.2 (continued)**  
**Model Parameters of MOSFETs**

Name	Model Parameter	Unit	Default	Typical
XQC	Fraction of channel charge attributed to drain		1	
DELTA	Width effect on threshold		0	
THETA	Mobility modulation (LEVEL = 3)	V <sup>-1</sup>	0	
ETA	Static feedback (LEVEL = 3)		0	
KAPPA	Saturation field factor (LEVEL = 3)		0.2	
KF	Flicker noise coefficient		0	1E-26
AF	Flicker noise exponent		1	1.2



**FIGURE 8.17** PSpice *n*-channel MOSFET model. (a) PSpice model, (b) DC model.

The LEVEL-2 model, which can take into consideration various parameters, requires considerable CPU time for the calculations and could cause convergence problems. The LEVEL-3 model introduces a smaller error than the LEVEL-2 model, and the CPU time is also approximately 25% less. The LEVEL-3 model is designed for MOSFETs with a short channel.

The parameters that affect the switching behavior of a BJT in power electronics applications are

```
L W VTO KP CGSO CGDO
```

The symbol of a metal-oxide silicon field-effect transistor (MOSFET) is M. The name of a MOSFET must start with M and takes the general form

```
M<name> ND NG NS NB MNAME
+ [L=<value>] [W=<value>]
+ [AD=<value>] [AS=<value>]
+ [PD=<value>] [PS=<value>]
+ [NRD=<value>] [NRS=<value>]
+ [NRG=<value>] [NRB=<value>]
```

where ND, NG, NS, and NB are the drain, gate, source, and bulk (or substrate) nodes, respectively. MNAME is the model name and can begin with any character; its word size is normally limited to eight characters. Positive current is the current that flows into a terminal. That is, the current flows from the drain node, through the device, to the source node for an  $n$ -channel MOSFET.

## 8.7 MOSFET PARAMETERS

The data sheet for an  $n$ -channel MOSFET of type IRF150 is shown in [Figure 8.18](#). The library file of the student version of PSpice supports a model of this MOSFET as follows:

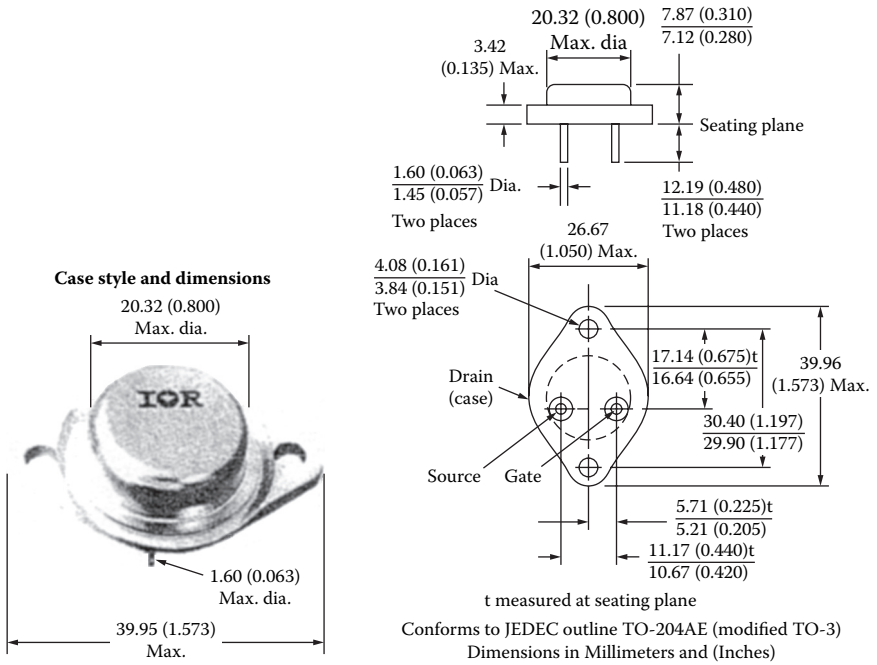
```
.MODEL IRF150 NMOS (TOX=100N PHI=.6 KP=20.53U W=.3
+ L=2U VTO=2.831 RD=1.031M RDS=444.4K CBD=3.229N
PB=.8 MJ=.5
+ CGSO=9.027N CGDO=1.679N RG=13.89 IS=194E-18 N=1
TT=288N)
```

However, we shall generate approximate values of some parameters [8, 9]. From the data sheet we get  $I_{DSS} = 250 \mu\text{A}$  at  $V_{GS} = 0 \text{ V}$ ,  $V_{DS} = 100 \text{ V}$ .  $V_{Th} = 2$  to  $4 \text{ V}$ . Geometric mean,  $V_{Th} = VTO = \sqrt{2 \times 4} = 2.83 \text{ V}$ . The constant  $K_p$  can be found from

$$I_D = K_p (V_{GS} - V_{Th})^2 \quad (8.5)$$

For  $I_D = I_{DSS} = 250 \mu\text{A}$ , and  $V_{Th} = 2.83 \text{ V}$ , Equation 8.5 gives  $K_p = 250 \mu\text{A}/2.83^2 = 31.2 \mu\text{A}/\text{V}^2$ .  $K_p$  is related to channel length  $L$  and channel width  $W$  by

$$K_p = \frac{\mu_a C_o}{2} \left( \frac{W}{L} \right) \quad (8.6)$$



**FIGURE 8.18** Data sheet for MOSFET of type IRF150. (Courtesy of International Rectifier.)

where  $C_o$  is the capacitance per unit area of the oxide layer, a typical value for a power MOSFET being  $3.5 \times 10^{-8}$  F/cm<sup>2</sup> at a thickness of 0.1  $\mu$ m, and  $\mu_a$  is the surface mobility of electrons, 600 cm<sup>2</sup>/(V · sec).

The ratio  $W/L$  can be found from

$$\frac{W}{L} = \frac{2K_p}{\mu_a C_o} = \frac{2 \times 31.2 \times 10^{-6}}{600 \times 3.5 \times 10^{-8}} = 3$$

Let  $L = 1 \mu$ m and  $W = 3000 \mu$ m = 3 mm  $C_{rss} = 350 - 500$  pF at  $V_{GS} = 0$ , and  $V_{DS} = 25$  V. The geometric mean,  $C_{rss} = C_{gd} = \sqrt{350 \times 500} = 418.3$  pF at  $V_{DG} = 25$  V.

For a MOSFET, the values of  $C_{gs}$  and  $C_{gd}$  remain relatively constant with changing  $V_{GS}$  or  $V_{DS}$ . They are determined mainly by the thickness and type of the insulating oxide. Although the curves of the capacitances vs. drain-source voltage show some variations, we will assume constant capacitances. Thus,  $C_{gdo} = 418.3$  pf and  $C_{iss} = 2000$  to 3000 pF. The geometric mean  $C_{iss} = \sqrt{2000 \times 3000} = 2450$  pF. Because  $C_{iss}$  is measured at  $V_{GS} = 0$  V,  $C_{gs} = C_{gso}$ . That is,

$$C_{iss} = C_{gso} + C_{gd}$$

**Absolute maximum ratings**

Parameter	IRF 150	IRF 151	IRF 152	IRF 153	Units
$V_{DS}$ Drain-Source voltage ①	100	60	100	60	V
$V_{DGR}$ Drain-Gate voltage ( $R_{GS} = 20\text{ k}\Omega$ ) ①	100	60	100	60	V
$I_D @ T_C = 25^\circ\text{C}$ Continuous drain current	40	40	33	33	A
$I_D @ T_C = 100^\circ\text{C}$ Continuous drain current	25	25	20	20	A
$I_{DM}$ Pulse drain current ③	160	160	132	132	A
$V_{GS}$ Gate - Source voltage	±20				V
$P_D @ T_C = 25^\circ\text{C}$ Max. power dissipation	150			(See Fig. 14)	W
Linear derating factor	1.2			(See Fig. 14)	W/K
$I_{LM}$ Inductive current, clamped	(See Fig. 15 and 16) $L = 100\ \mu\text{H}$				A
	160	160	132	132	A
$T_J$ Operating junction and $T_{stg}$ Storage temperature range	-55 to 150				°C
Lead temperature	300 (0.063 in. (1.6 mm) from case for 10s)				°C

**Electrical characteristics @  $T_C = 25^\circ\text{C}$  (Unless otherwise specified)**

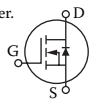
Parameter	Type	Min.	Typ.	Max.	Units	Test conditions
$BV_{DSS}$ Drain-Source breakdown voltage	IRF 150 IRF 152	100	-	-	V	$V_{GS} = 0\text{ V}$ $I_D = 250\ \mu\text{A}$
	IRF 151 IRF 153	60	-	-	V	
	All	2.0	-	4.0	V	
$V_{GS(th)}$ Gate threshold voltage	All	-	-	100	nA	$V_{GS} = 20\text{ V}$
$I_{GSS}$ Gate-Source leakage forward	All	-	-	-100	nA	$V_{GS} = 0.20\text{ V}$
$I_{DSS}$ Zero gate voltage drain current	All	-	-	250	$\mu\text{A}$	$V_{DS} = \text{Max. rating}, V_{GS} = 0\text{ V}$
		-	-	1000	$\mu\text{A}$	$V_{DS} = \text{Max. rating} \times 0.8, V_{GS} = 0\text{ V}, T_C = 125^\circ\text{C}$
$I_{D(on)}$ On-State drain current②	IRF 150 IRF 151	40	-	-	A	$V_{DS} > I_{D(on)} \times R_{DS(on)max}, V_{GS} = 10\text{ V}$
	IRF 152 IRF 153	33	-	-	A	
	IRF 150 IRF 151	-	0.045	0.055	$\Omega$	
IRF 152 IRF 153	-	0.06	0.08	$\Omega$		
$g_{fs}$ Forward transconductance ②	All	9.0	11	-	S(T)	$V_{DS} > I_{D(on)} \times R_{DS(on)max}, I_D = 20\text{ A}$
$C_{iss}$ Input capacitance	All	-	2000	3000	pF	$V_{GS} = 0\text{ V}, V_{DS} = 25\text{ V}, f = 1.0\text{ MHz}$ See Fig. 10
$C_{oss}$ Output capacitance	All	-	1000	1500	pF	
$C_{rss}$ Reverse transfer capacitance	All	-	350	500	pF	
$t_{d(on)}$ Turn-on delay time	All	-	-	35	ns	$V_{DD} = 24\text{ V}, I_D = 20\text{ A}, Z_o = 4.7\ \Omega$ See figure 17. (MOSFET switching times are essentially independent of operating temperature.)
$t_r$ Rise time	All	-	-	100	ns	
$t_{d(off)}$ Turn-off delay time	All	-	-	125	ns	
$t_f$ Fall time	All	-	-	100	ns	
$Q_g$ Total gate charge (Gate-Source plus Gate-Drain)	All	-	63	120	nC	$V_{GS} = 10\text{ V}, I_D = 50\text{ A}, V_{DS} = 0.8\text{ max. rating.}$ See Fig. 18 for test circuit. (Gate charge is essentially independent of operating temperature.)
$Q_{gs}$ Gate-Source charge	All	-	27	-	nC	
$Q_{gd}$ Gate-Drain ("Miller") charge	All	-	36	-	nC	
$L_D$ Internal drain inductance	All	-	5.0	-	nH	Measured between the contact screw on header that is closer to source and gate pins and center of die.
$L_S$ Internal source inductance	All	-	12.5	-	nH	Measured from the source pin, 6 mm (0.25 in.) from header and source bonding pad.

**Thermal resistance**

$R_{thJC}$ Junction-to-case	All	-	-	0.83	K/W	
$R_{thCS}$ Case-to-sink	All	-	0.1	-	K/W	Mounting surface flat, smooth, and greased.
$R_{thJA}$ Junction-to-Ambient	All	-	-	0.83	K/W	Free air operation

**FIGURE 8.18** (continued).

Source-Drain diode ratings and characteristics

$I_S$	Continuous source current (Body diode)	IRF 150	-	-	40	A	Modified MOSFET symbol showing the integral reverse P-N junction rectifier. 
		IRF 152	-	-	33	A	
$I_{SM}$	Pulse source current (Body diode) ③	IRF 150	-	-	160	A	
		IRF 152	-	-	132	A	
$V_{SD}$	Diode forward voltage ②	IRF 150	-	-	2.5	V	$T_C = 25^\circ\text{C}, I_S = 40\text{ A}, V_{GS} = 0\text{ V}$
		IRF 152	-	-	2.3	V	$T_C = 25^\circ\text{C}, I_S = 33\text{ A}, V_{GS} = 0\text{ V}$
$t_{rr}$	Reverse recovery time	All	-	600	-	ns	$T_J = 150^\circ\text{C}, I_F = 40\text{ A}, dI_F/dt = 100\text{ A}/\mu\text{s}$
$Q_{RR}$	Reverse recovered charge	All	-	3.3	-	$\mu\text{C}$	$T_J = 150^\circ\text{C}, I_F = 40\text{ A}, dI_F/dt = 100\text{ A}/\mu\text{s}$
$t_{on}$	Forward Turn-on time	All	Intrinsic turn-on time is negligible. Turn-on speed is substantially controlled by $L_S + L_D$ .				

- ①  $T_J = 25^\circ\text{C}$  to  $150^\circ\text{C}$ . ② Pulse test: Pulse width  $\leq 300\ \mu\text{s}$ , Duty cycle  $\leq 2\%$ . ③ Repetitive rating: Pulse width limited by max. junction temperature. See transient thermal impedance curve (Fig. 5).

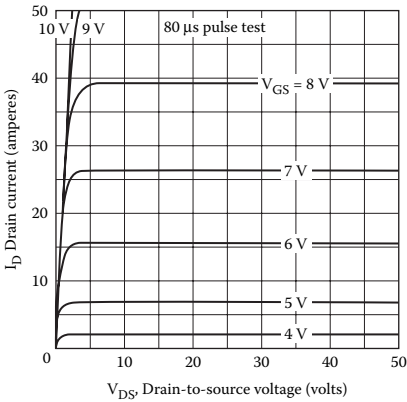


Fig. 1—Typical output characteristics

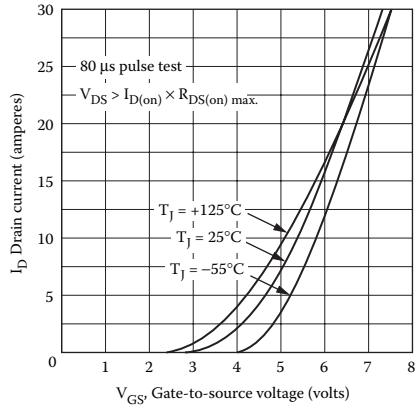


Fig. 2—Typical transfer characteristics

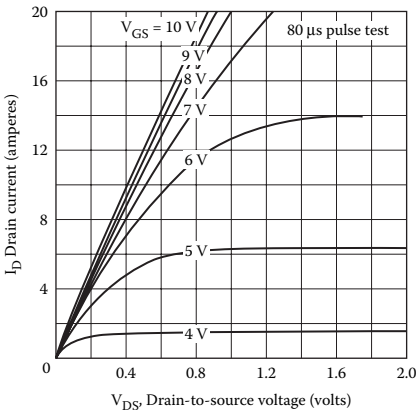


Fig. 3—Typical saturation characteristics

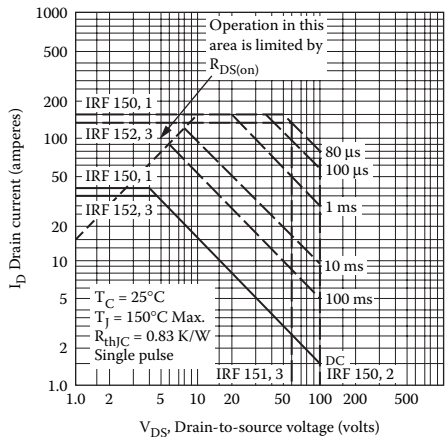


Fig. 4—Maximum safe operating area

FIGURE 8.18 (continued).

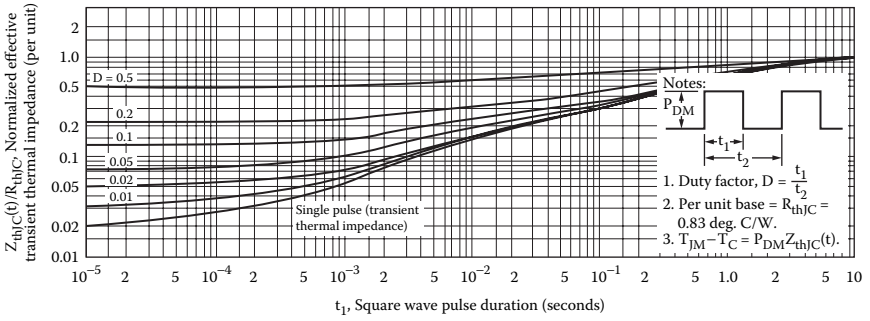


Fig. 5--Maximum effective transient thermal impedance, junction-to-case vs. pulse duration

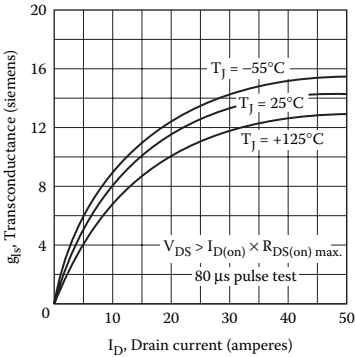


Fig. 6--Typical transconductance vs. drain current

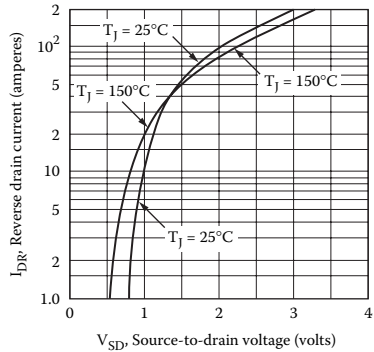


Fig. 7--Typical source-drain diode forward voltage

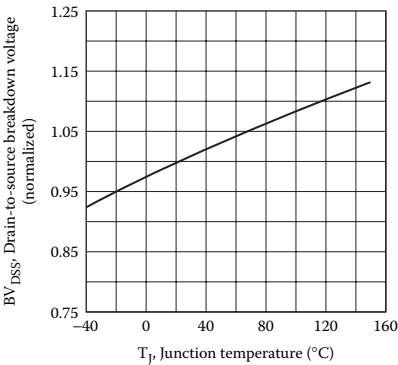


Fig. 8--Breakdown voltage vs. temperature

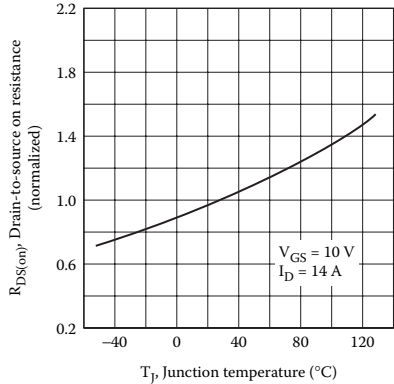


Fig. 9--Normalized on-resistance vs. temperature

FIGURE 8.18 (continued).

IRF150, IRF151, IRF152, IRF153 Devices

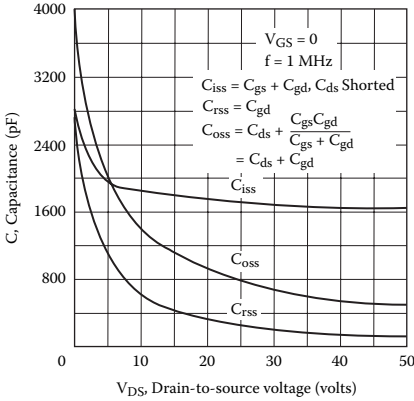


Fig. 10—Typical capacitance vs. drain-to-source voltage

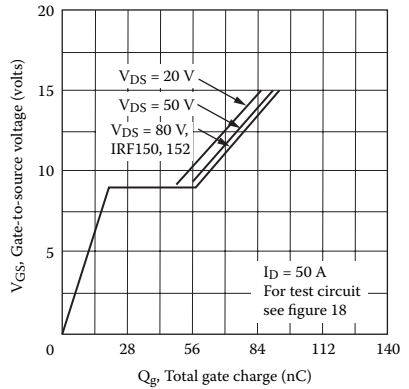


Fig. 11—Typical gate charge vs. gate-to-source voltage

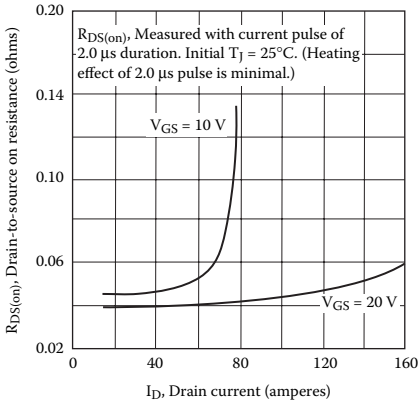


Fig. 12—Typical on-resistance vs. drain current

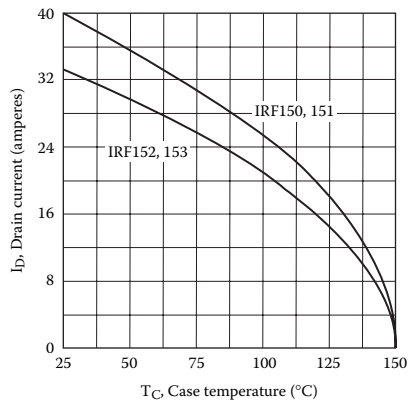


Fig. 13—Maximum drain current vs. case temperature

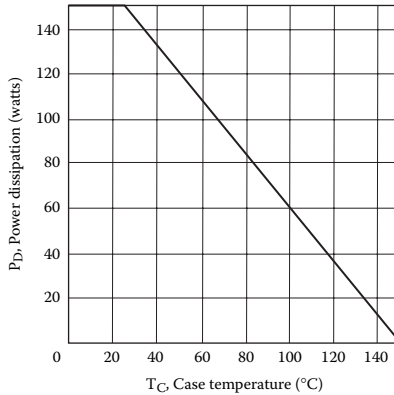


FIGURE 8.18 (continued).

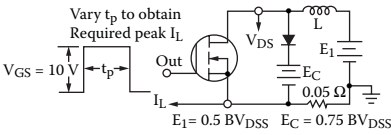


Fig. 15-Clamped inductive test circuit

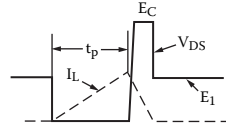


Fig. 16-Clamped inductive waveforms

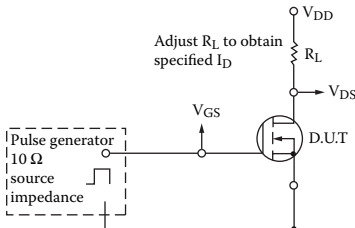


Fig. 17-Switching time test circuit

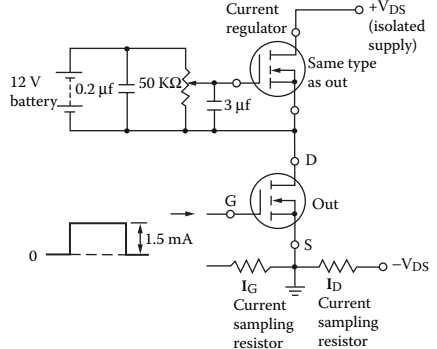


Fig. 18-Gate charge test circuit

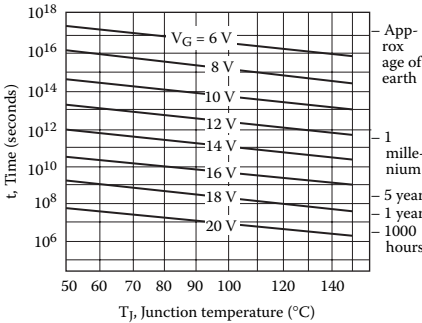
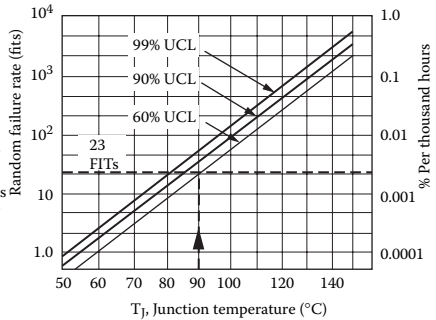


Fig. 19-Typical time to accumulated 1% failure



\*Fig. 20-Typical high temperature reverse bias (HTRB) failure rate

\*The data shown is correct as of April 15, 1984. This information is updated on a quarterly basis; for the latest reliability data, please contact your local IR field office.

**FIGURE 8.18** (continued).

which gives  $C_{gso} = C_{iss} - C_{sd} = 2450 - 418.3 = 2032 \text{ pF} = 2.032 \text{ nF}$ . Thus, the PSpice model statement for MOSFET IRF150 is

```
.MODEL IRF150 NMOS (VTO=2.83 KP=31.2U L=1U W=30M
CGDO=0.418N CGSO=2.032N)
```

The model can be used to plot the characteristic of the MOSFET. It may be necessary to modify the parameter values to conform with the actual characteristics. It should be noted that the parameters differ from those given in the PSpice library, because their values are dependent on the constants used in derivations.

Students are encouraged to run the following circuit file with the PSpice library model and compare the results.

*Note:* The gate (control) voltage  $V_g$  should be adjusted to drive the MOSFET into saturation.

### 8.8 EXAMPLES OF MOSFET CHOPPERS

#### EXAMPLE 8.5 FINDING THE PERFORMANCE OF CUK DC–DC CONVERTER WITH A BJT SWITCH

A MOSFET boost chopper is shown in Figure 8.19(a). The DC input voltage is  $V_S = 5\text{ V}$ . The load resistance  $R$  is  $100\ \Omega$ . The inductance is  $L = 150\ \mu\text{H}$ , and the filter capacitance is  $C = 220\ \mu\text{F}$ . The chopping frequency is  $f_c = 25\text{ kHz}$ , and the duty cycle of the chopper is  $k = 66.7\%$ . The control voltage is shown in Figure 8.19(b). Use PSpice to plot the instantaneous output voltage  $v_c$ , the input current  $i_s$ , and the MOSFET voltage  $v_T$ . Plot the frequency response of the converter output voltage from 10 Hz to 10 kHz and find the resonant frequency.

#### SOLUTION

The DC supply voltage  $V_S = 5\text{ V}$ . An initial capacitor voltage  $V_C = 12\text{ V}$ ,  $k = 0.667$ ,  $f_c = 25\text{ kHz}$ , and  $T = 1/f_c = 40\ \mu\text{sec}$ , and  $t_{\text{on}} = k \times T = 0.667 \times 40 = 26.7\ \mu\text{sec}$ .

The PSpice schematic is shown in Figure 8.20. A voltage-controlled voltage source with a gain of six drives the MOSFET switch. The PWM generator is implemented

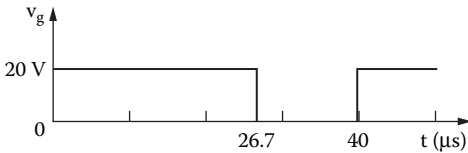
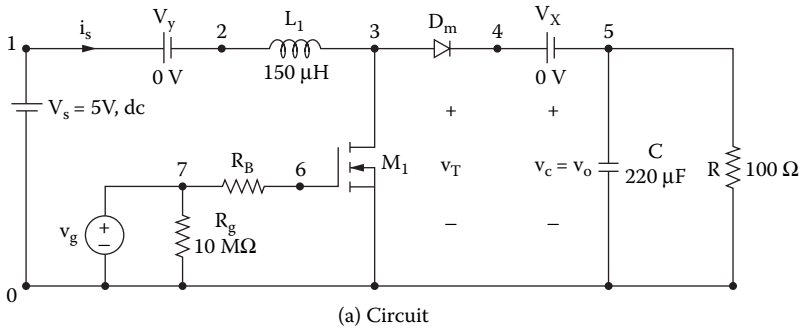


FIGURE 8.19 MOSFET boost chopper for PSpice simulation. (a) Circuit, (b) gate voltage.

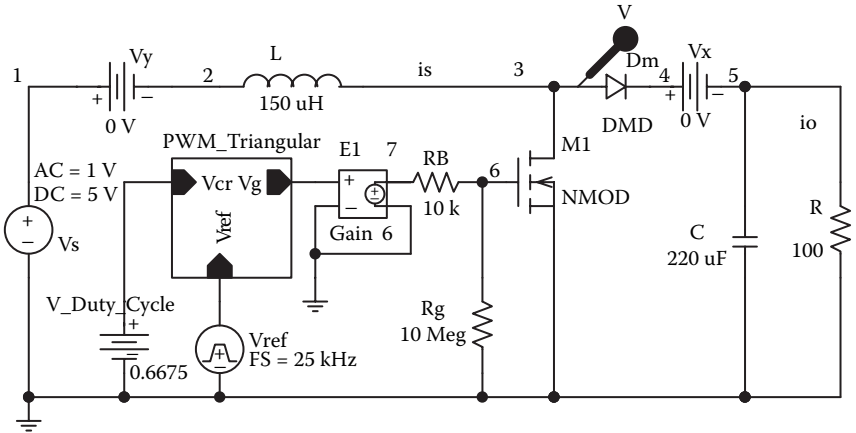


FIGURE 8.20 PSpice schematic for Example 8.5.

as a descending hierarchy as shown in Figure 8.3(b). The model parameters for the NMOS switch and the freewheeling diode are as follows:

```
.MODEL NMOS NMOS (VTO=2.83 KP=31.2U L=1U W=30M
CGDO=0.418N CGSO=2.032N)
.MODEL DMD D(IS=2.22E-15 BV=1200V CJO=1PF TT=0US))
```

The list of the circuit file is as follows:

**Example 8.5 MOSFET boost chopper**

```
SOURCE ■ VS 1 0 DC 5V
        VY 1 2 DC 0V ; Voltage source to measure input current
        Vg 7 0 PULSE (0V 6V 0 0.1NS 0.1NS 26.7US 40US)
        Rg 7 0 10MEG
CIRCUIT ■■ RB 7 6 10k ; Transistor base resistance
           R 5 0 100
           C 5 0 220UF IC=12V ; With initial condition
           L 2 3 150UH
           VX 4 5 DC 0V ; Voltage source to inductor current
           DM 3 4 DMOD ; Freewheeling diode
           .MODEL DMOD D(IS=2.22E-15 BV=1200V IBV=13E-3
CGDO=0 TT=0) ;Diode model
           M1 3 6 0 0 IRF150 ; MOSFET switch
           .MODEL IRF150 NMOS (VTO=2.83 KP=31.2U L=1U W=30M
+ CGDO=0.418N CGSO=2.032N) ; MOSFET parameters
```

```

ANALYSIS ■■■ .TRAN 0.1US 2MS 1.8MS UIC ; Transient analysis with
initial conditions
.PROBE ; Graphics post-processor
.OPTIONS ABSTOL = 1.00N RELTOL = 0.01 VNTOL = 0.1
ITL5 = 40000
.FOUR 25KHZ I(VY) ; Fourier analysis
.END

```

The PSpice plots of the instantaneous MOSFET voltage V(3), the input current I(VY), and the output voltage V(5) are shown in Figure 8.21(a). The output voltage has not reached the steady state. Figure 8.21(b) gives the resonant frequency of  $f_{\text{res}} = 796.14$  Hz at a resonant peak gain of  $A_{\text{o(peak)}} = 1.71$ .

*Note:* The base drive voltage is reduced to 60 V. For a duty cycle of  $k = 0.6675$ , the average load voltage [1] is  $V_{\text{o(av)}} = V_s/(1 - k) = 5/(1 - 0.6675) = 15$  V (PSpice gives 13.0 V). The load voltage has not yet reached the steady-state value.

## 8.9 IGBT MODEL

The IGBT shown in Figure 8.22(a) behaves as a MOSFET from the input side and as a BJT from the output side. The modeling of an IGBT is very complex [8].

There are two main ways to model IGBT in SPICE: (1) composite model and (2) equation model. The composite model connects the existing BJT and MOSFET models of PSpice in a Darlington configuration and uses their built-in equations. The equivalent circuit of the composite model is shown in Figure 8.22(b). This model computes quickly and reliably, but it does not model the behavior of the IGBT accurately.

The equation model [16,17] implements the physics-based equations and models the internal carrier and charge to simulate the circuit behavior of the IGBT accurately. This model is complicated, often unreliable and computationally slow because the equations are derived from the complex semiconductor physics theory. Simulation times can be over ten times longer than for the composite model.

There are numerous papers on SPICE modeling of IGBTs. Sheng [18] compares the merits and limitations of various models. Figure 8.22(c) shows the equivalent circuit of Sheng's model [15], which adds a current source from the drain to the gate. The major inaccuracy in dynamic electrical properties [15] is associated with the modeling of the drain to gate capacitance of the  $n$ -channel MOSFET. During high-voltage switching, the drain-to-gate capacitance  $C_{\text{dg}}$  changes by two orders of magnitude due to any changes in drain-to-gate voltage  $V_{\text{dg}}$ . This is,  $C_{\text{dg}}$  is expressed by

$$C_{\text{dg}} = \frac{\epsilon_{\text{si}} C_{\text{oxd}}}{\sqrt{\frac{2\epsilon_{\text{si}} V_{\text{dg}}}{qN_{\text{B}}} C_{\text{oxd}} + A_{\text{dg}} \epsilon_{\text{si}}}}$$

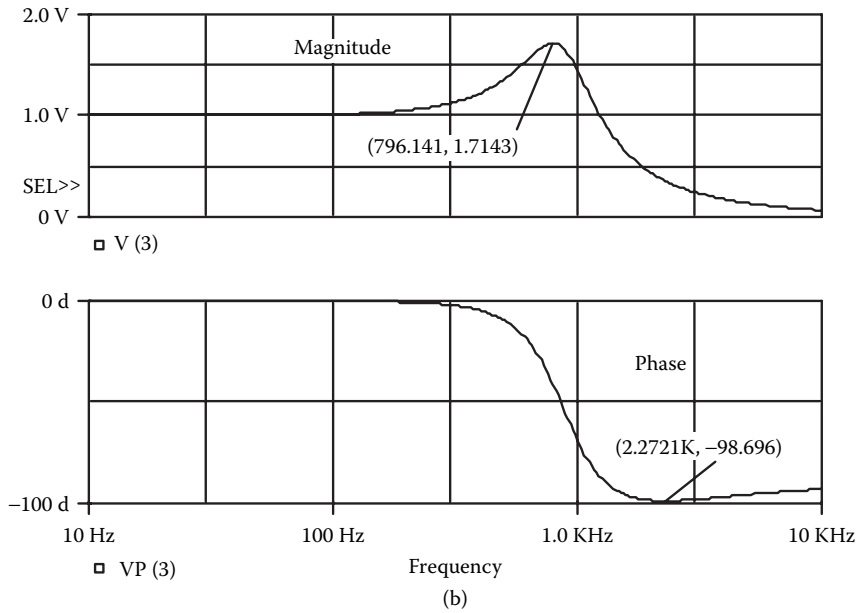
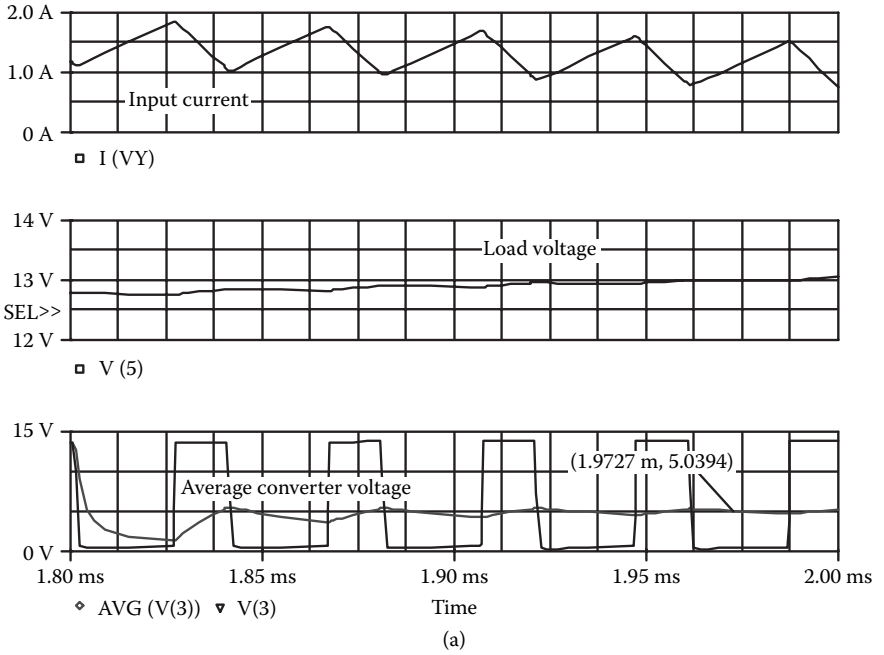
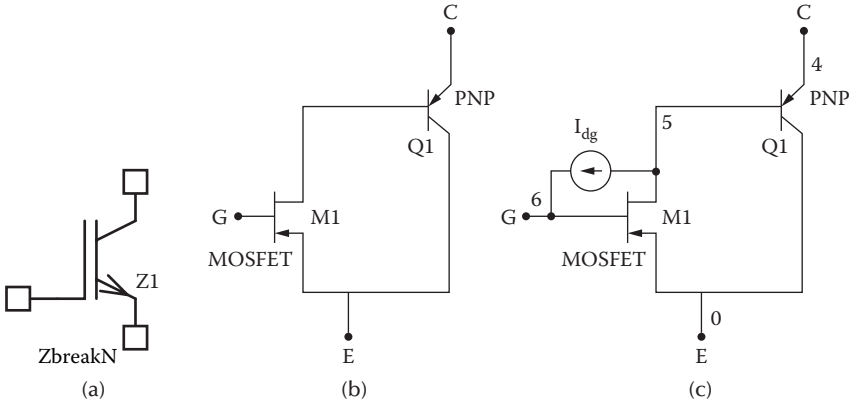


FIGURE 8.21 Plots for Example 8.5. (a) Transient plots, (b) frequency response.



**FIGURE 8.22** Equivalent circuits of IGBT SPICE models. (a) *n*-type IGBT, (b) composite model, (c) Sheng PSpice model.

PSpice Schematics does not incorporate a capacitance model involving the square root, which models the space charge layer variation for a step junction. PSpice model can implement the equations describing the highly nonlinear gate–drain capacitance into the composite model by using the analog behavioral modeling function of PSpice.

The student version of the PSpice Schematics or OrCAD library comes with one breakout IGBT device, ZbreakN, and one real device, IXGH40N60. Although a complex model is needed for accurately simulating the behavior of an IGBT circuit, these simple PSpice IGBT models can simulate the behavior of a converter for most applications. The model parameters of the IGBT of IXGH40N60 are as follows:

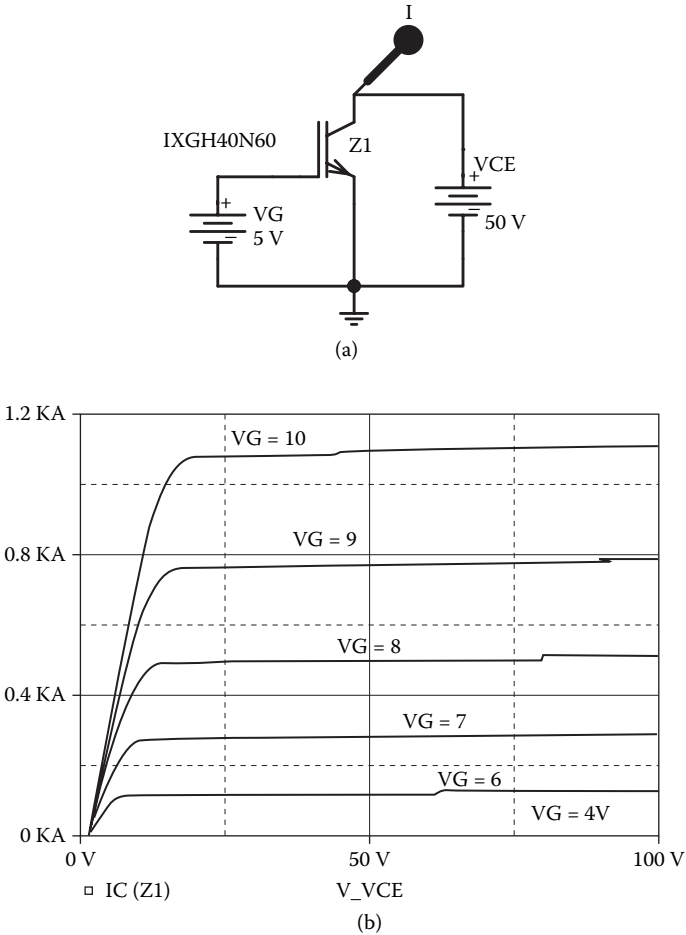
```
.MODEL IXGH40N60 NIGBT (TAU=287.56E-9 KP=50.034
AREA=37.500E-6
+ AGD=18.750E-6 VT=4.1822 KF=.36047 CGS=31.942E-9
COXD=53.188E-9 VTD=2.6570
```

**EXAMPLE 8.6 PLOTTING THE OUTPUT AND TRANSFER CHARACTERISTICS OF AN IGBT**

Use PSpice to plot the output characteristics ( $V_{CE}$  vs.  $I_C$ ) of the IGBT for  $V_{CE} = 0$  to 100 V and  $V_{GS} = 4$  V to 210 V.

**SOLUTION**

The PSpice schematic of an *n*-type IGBT is shown in Figure 8.23(a). The output characteristics  $I_C$  vs.  $V_{CE}$  are shown in Figure 8.23(b). The transfer characteristics  $I_C$  vs.  $V_G$  are shown in Figure 8.23(c), which gives the threshold voltage  $V_T = 4.1049$  V. An ZberakN device will permit adjustment of the model parameters. At a gate voltage less than the threshold voltage, the device remains off.



**FIGURE 8.23** Transfer characteristic of a typical *n*-type IGBT. (a) Schematic, (b) output characteristics, (c) transfer characteristics.

**EXAMPLE 8.7 FINDING THE PERFORMANCE OF CDK DC-DC CONVERTER WITH AN IGBT SWITCH**

If the switch is replaced by an IGBT in Example 8.5, plot the worst-case average and instantaneous load voltages if the tolerances of the capacitor, inductor, and resistor are  $\pm 20\%$  (with standard deviation). Assume  $C = 5 \mu\text{F}$ .

**SOLUTION**

The PSpice schematic is shown in Figure 8.24. A voltage-controlled voltage source with a gain of six drives the MOSFET switch. The PWM generator is implemented as a descending hierarchy as shown in Figure 8.3(b). The model parameters for the IGBT switch and the freewheeling diode are as follows:

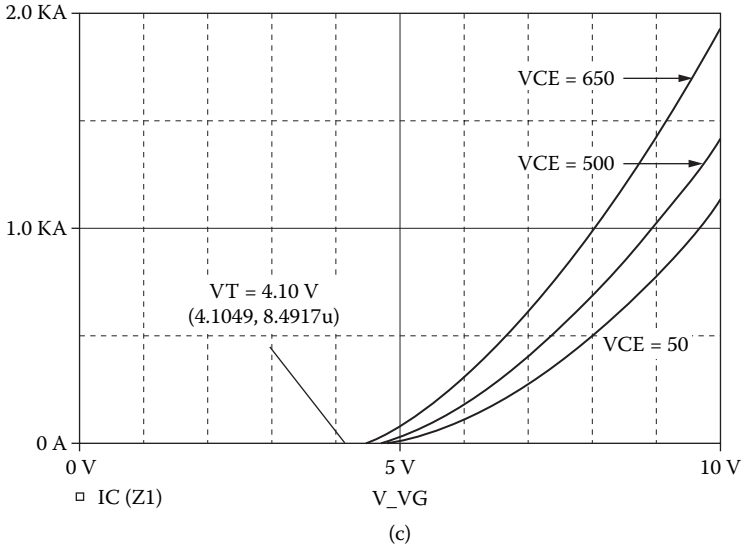


FIGURE 8.23 (continued).

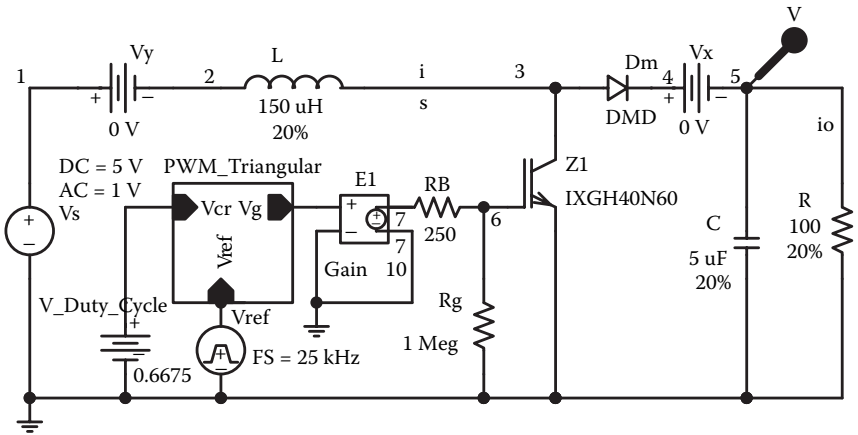
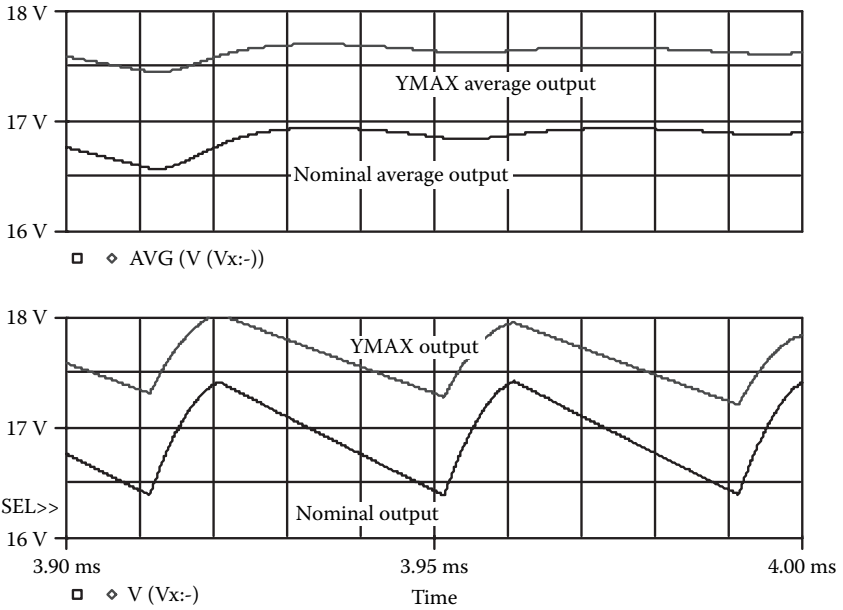


FIGURE 8.24 PSpice schematic for Example 8.7.

```
.MODEL IXGH40N60 NIGBT (TAU=287.56E-9 KP=50.034
AREA=37.500E-6
+ AGD=18.750E-6 VT=4.1822 KF=.36047 CGS=31.942E-9
COXD=53.188E-9 VTD=2.6570
.MODEL DMD D(IS=2.22E-15 BV=1200V CJO=1PF TT=0US))
```

The plots of the average and instantaneous output voltages are shown in Figure 8.25 under nominal and maximum worst-case conditions. With the specified toler-



**FIGURE 8.25** Worst-case and nominal output voltages for Example 8.7.

ances, the difference is approximately +0.5 V. For the output files, the sensitivity of each component on the output could be found.

### 8.10 LABORATORY EXPERIMENT

The following two experiments are suggested to demonstrate the operation and characteristics of DC choppers:

- DC buck chopper
- DC boost chopper

#### 8.10.1 EXPERIMENT TP.1

##### DC BUCK CHOPPER

- Objective** To study the operation and characteristics of a DC buck chopper under various load conditions.
- Applications** The DC buck (step-down) chopper is used to control power flow in power supplies, DC motor control, input stages to inverters, etc.
- Textbook** See [Reference 12](#), Section. 5.3 and Section 5.7.
- Apparatus**
1. One BJT/MOSFET with ratings of at least 50 A and 500 V, mounted on a heat sink
  2. One fast-recovery diode with ratings of at least 50 A and 500 V, mounted on a heat sink

3. A firing pulse generator with isolating signals for gating the BJT
4. An  $RL$  load
5. One dual-beam oscilloscope with floating or isolating probes
6. DC voltmeters and ammeters and one noninductive shunt

**Warning**

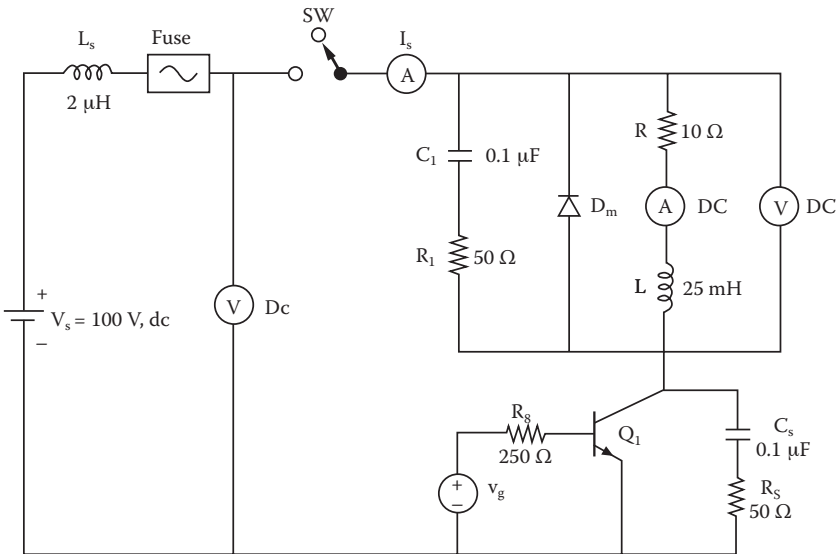
Before making any circuit connection, switch the DC power off. Do not switch on the power unless the circuit is checked and approved by your laboratory instructor. Do not touch the transistor heat sinks, which are connected to live terminals.

**Experimental procedure**

1. Set up the circuit as shown in Figure 8.26. Use a load resistance  $R$  only.
2. Connect the measuring instruments as required.
3. Set the chopping frequency to  $f_c = 1$  kHz and the duty cycle to  $k = 50\%$ .
4. Connect the firing pulse to the BJT/MOSFET.
5. Observe and record the waveforms of the load voltage  $v_o$ , the load current  $i_o$ , and the input current  $i_s$ .
6. Measure the average load voltage  $V_{o(DC)}$ , the average load current  $I_{o(DC)}$ , the rms transistor current  $I_{T(rms)}$ , the average input current  $I_{s(DC)}$ , and the load power  $P_L$ .
7. Repeat steps 2 to 6 with a load inductance  $L$  only.
8. Repeat steps 2 to 6 with both load resistance  $R$  and load inductance  $L$ .

**Report**

1. Present all recorded waveforms and discuss all significant points.
2. Compare the waveforms generated by SPICE with the experimental results, and comment.
3. Compare the experimental results with the predicted results.
4. Calculate and plot the average output voltage  $V_{o(DC)}$  against the duty cycle.
5. Discuss the advantages and disadvantages of this type of chopper.



**FIGURE 8.26** BJT step-down chopper.

## 8.10.2 EXPERIMENTAL TP-2

### DC BOOST CHOPPER

<b>Objective</b>	To study the operation and characteristics of a DC boost chopper under various load conditions.
<b>Applications</b>	The DC boost (step-up) chopper is used to control power flow in power supplies, DC motor control, input stages to inverters, etc.
<b>Textbook</b>	See Reference 12, Section 5.4 and Section 5.7.
<b>Apparatus</b>	See Experiment TP.1.
<b>Warning</b>	See Experiment TP.1.
<b>Experimental procedure</b>	Set up the circuit as shown in Figure 8.27. Repeat the steps of Experiment TP.1.
<b>Report</b>	See Experiment TP-1.

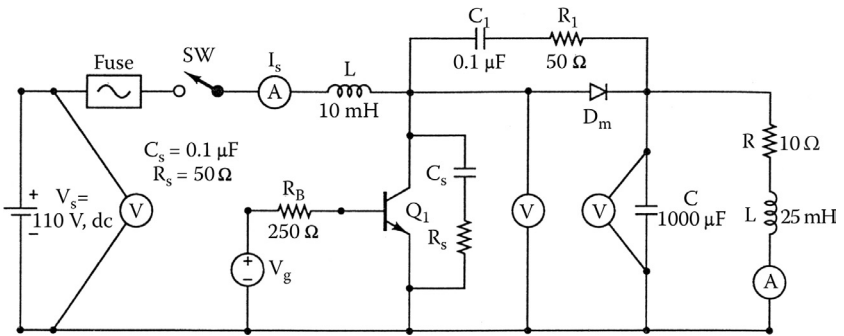


FIGURE 8.27 BJT step-up chopper.

## 8.11 SUMMARY

The statements of BJTS are:

```
Q<name> NC NB NE NS QNAME [(area) value]
.MODEL QNAME NPN (P1=B1 P2=B2 P3=B3 ... PN=VN)
.MODEL QNAME NPN (P1=B1 P2=B2 P3=B3 ... PN=VN)
```

The statements for MOSFETs are

```
M<name> ND NG NS NB MNAME
+ [L=<value>] [W=<value>]
+ [AD=<value>] [AS=<value>]
+ [PD=<value>] [PS=<value>]
+ [NRD=<value>] [NRS=<value>]
```

```
+ [NRG=<value>] [NRB=<value>]
.MODEL MNAME NMOS (P1=V1 P2=V2 P3=V3 ... PN=VN)
.MODEL MNAME PMOS (P1=V1 P2=V2 P3=V3 ... PN=VN)
```

The statements for JGBTs are:

```
Z1 NC NG NE ZNAME
.MODEL ZNAME NIGBT (P1=B1 P2=B2 ... PN=BN) for
N-type
MODEL ZNAME PIGBT (P1=B1 P2=B2 ... PN=BN) for
P-type
```

## Suggested Reading

1. Ian Getreu, *Modeling the Bipolar Transistor*, Part # 062-2841-00. Beaverton, OR.: Tektronix, 1979.
2. H.K. Gummel and H.C. Poon, An integral charge control model for bipolar transistors, *Bell Systems Technical Journal*, Vol. 49, January 1970, pp. 115–120.
3. J.J. Ebers and J.J. Moll, Large signal behavior of junction transistors, *Proceedings of the IRE*, Vol. 42, December 1954, pp. 1161–1172.
4. H. Schichman and D.A. Hodges, Modeling and simulation of insulated gate field effect transistor switching circuits, *IEEE Journal of Solid-State Circuits*, Vol. SC-3, September 1968, pp. 285–289.
5. J.F. Meyer, MOS models and circuit simulation, *RCA Review*, Vol. 32, March 1971, pp. 42–63.
6. A. Vladimirescu and S. Liu, *The Simulation of MOS Integrated Circuits Using SPICE2*, Memorandum M80/7, February 1980, University of California, Berkeley.
7. S. Hangeman, Behavioral modeling and PSpice simulation SMPS control loops: Parts I and II, *PCIM Magazine*, April–May 1990.
8. P.O. Lauretzen, Power semiconductor device models for use in circuit simulation, *Conference Proceedings of the IEEE-IAS Annual Meeting*, 1990, pp. 1559–1560.
9. S. Natarajan, An effective approach to obtain model parameters for BJTs and FETs from data books, *IEEE Transactions on Education*, Vol. 35, No. 2, 1992, pp. 164–169.
10. G. Fay and J. Sutor, Power FET models are easy and accurate, *Powertechnics Magazine*, August 1987, pp. 16–21.
11. C.F. Wheatley, H.R. Ronan, Jr., and G.M. Dolny, Spicing up SPICE II software for power MOSFET modeling, *Powertechnics Magazine*, August 1987, pp. 28–32.
12. M.H. Rashid, *Power Electronics: Circuits, Devices, and Applications*, 2nd ed., Englewood Cliffs, NJ: Prentice Hall, 1993.
13. M.H. Rashid, *Introduction to PSpice Using OrCAD for Circuits and Electronics*, 3rd ed., Englewood Cliff, NJ: Prentice-Hall, 2003, chap. 8 and 9.
14. B.J. Baliga, *Power Semiconductor Devices*. Boston, MA: PWS Publishing, 1996.

15. K. Sheng, S.J. Finney, and B.W. Williams, Fast and accurate IGBT model for PSpice, *Electronics Letters*, Vol. 32, No. 25, December 5, 1996, pp. 2294–2295.
16. A.G.M. Strollo, A new IGBT circuit model for SPICE simulation, *Power Electronics Specialists Conference*, June 1997, Vol. 1, pp. 133–138.
17. K. Sheng, S.J. Finney, and B.W. Williams, A new analytical IGBT model with improved electrical characteristics, *IEEE Transactions on Power Electronics* Vol. 14, No. 1, January 1999, pp. 98–107.
18. K. Sheng, B.W. Williams, and S.J. Finney, A review of IGBT models, *IEEE Transactions on Power Electronics*, Vol. 15, No. 6, November 2000, pp. 1250–1266.

## DESIGN PROBLEMS

### 8.1

It is required to design the step-up chopper of [Figure 8.19](#) with the following specifications:

DC supply voltage,  $V_s = 110 \text{ V}$

Load resistance,  $R = 5 \Omega$

Load inductance,  $L = 15 \text{ mH}$

DC output voltage  $V_{o(\text{DC})}$  is 80% of the maximum value

Peak-to-peak load ripple current should be less than 10% of the load average value,  $I_{o(\text{DC})}$

- (a) Determine the ratings of all devices and components under worst-case conditions.
- (b) Use SPICE to verify your design.
- (c) Provide a cost estimate of the circuit.

### 8.2

- (a) Design an input  $LC$  filter for the chopper of Problem 8.1. The harmonic content of the input current should be less than 10% of the value without the filter.
- (b) Use SPICE to verify your design in part (a).

### 8.3

It is required to design a step-up chopper of [Figure 8.19](#) with the following specifications:

DC supply voltage,  $V_s = 24 \text{ V}$

Load resistance,  $R = 5 \Omega$

Load inductance,  $L = 15 \text{ mH}$

DC output voltage  $V_{o(\text{DC})}$  is 150% of the maximum value

Average load current,  $I_{o(\text{DC})} = 2.5 \text{ A}$

Peak-to-peak load ripple current should be less than 10% of the load average value,  $I_{o(\text{DC})}$

- (a) Determine the ratings of all devices under worst-case conditions.
- (b) Use SPICE to verify your design.
- (c) Provide a cost estimate of the circuit.

## 8.4

- (a) Design an output  $C$  filter for the chopper of Problem 8.3. The harmonic content of the output voltage should be less than 10% of the value without the filter.
- (b) Use SPICE to verify your design in part (a).

## 8.5

It is required to design a buck regulator with the following specifications:

DC input voltage,  $V_s = 15 \text{ V}$

Average output voltage,  $V_{o(\text{DC})} = 10 \text{ V}$

Average load current,  $I_{o(\text{DC})} = 2.5 \text{ A}$

Peak-to-peak output ripple voltage should be less than 50 mV

Switching frequency,  $f_c = 20 \text{ kHz}$

Peak-to-peak inductor ripple current should be less than 0.5 A

- (a) Determine the ratings of all devices and components under worst-case conditions.
- (b) Use SPICE to verify your design.
- (c) Provide a cost estimate of the circuit.

## 8.6

It is required to design a boost regulator with the following specifications:

DC input voltage,  $V_s = 12 \text{ V}$

Average output voltage,  $V_{o(\text{DC})} = 24 \text{ V}$

Average load current,  $I_{o(\text{DC})} = 2.5 \text{ A}$

Switching frequency,  $f_c = 20 \text{ kHz}$

Peak-to-peak output ripple voltage should be less than 50 mV

Peak-to-peak inductor ripple current should be less than 0.5 A

- (a) Determine the ratings of all devices and components under worst-case conditions.
- (b) Use SPICE to verify your design.
- (c) Provide a cost estimate of the circuit.

## 8.7

It is required to design a buck–boost regulator with the following specifications:

DC input voltage,  $V_s = 15$  V

Average output voltage,  $V_{o(\text{DC})} = 10$  V

Average load current,  $I_{o(\text{DC})} = 2.5$  A

Switching frequency,  $f_c = 20$  kHz

Peak-to-peak output ripple voltage should be less than 50 mV

Peak-to-peak ripple current of inductor should be less than 0.2 A

- Determine the ratings of all devices and components under worst-case conditions.
- Use SPICE to verify your design.
- Provide a cost estimate of the circuit.

## 8.8

It is required to design a cuk regulator with the following specifications:

DC input voltage,  $V_s = 15$  V

Average output voltage,  $V_{o(\text{DC})} = 10$  V

Average load current,  $I_{o(\text{DC})} = 2.5$  A

Switching frequency,  $f_c = 20$  kHz

Peak-to-peak ripple voltages of capacitors should be less than 50 mV

Peak-to-peak ripple currents of inductors should be less than 0.2 A

- Determine the ratings of all devices and components under worst-case conditions.
- Use SPICE to verify your design.
- Provide a cost estimate of the circuit.

## 8.9

Assuming  $\pm 20\%$  tolerances with standard deviations for all capacitors, inductors, and resistors, plot the worst-case average and instantaneous load voltages for Problem 8.1.

## 8.10

Assuming  $\pm 20\%$  tolerances with standard deviations for all capacitors, inductors, and resistors, plot the worst-case average and instantaneous load voltages for Problem 8.2.

## 8.11

Assuming  $\pm 20\%$  tolerances with standard deviations for all capacitors, inductors, and resistors, plot the worst-case average and instantaneous load voltages for Problem 8.3.

**8.12**

Assuming  $\pm 20\%$  tolerances with standard deviations for all capacitors, inductors, and resistors, plot the worst-case average and instantaneous load voltages for Problem 8.4.

**8.13**

Assuming  $\pm 20\%$  tolerances with standard deviations for all capacitors, inductors, and resistors, plot the worst-case average and instantaneous load voltages for Problem 8.5.

**8.14**

Assuming  $\pm 20\%$  tolerances with standard deviations for all capacitors, inductors, and resistors, plot the worst-case average and instantaneous load voltages for Problem 8.6.

**8.15**

Assuming  $\pm 20\%$  tolerances with standard deviations for all capacitors, inductors, and resistors, plot the worst-case average and instantaneous load voltages for Problem 8.7.

**8.16**

Assuming  $\pm 20\%$  tolerances with standard deviations for all capacitors, inductors, and resistors, plot the worst-case average and instantaneous load voltages for Problem 8.8.

---

# 9 Pulse-Width-Modulated Inverters

The learning objectives of this chapter are:

- Modeling BJTs and IGBTs in SPICE, and specifying their mode parameters.
- Modeling of pulse-width modulation (PWM) control in SPICE as a hierarchy block.
- Performing transient analysis of voltage-source and current-source inverters.
- Evaluating the performance of voltage-source and current-source inverters.

## 9.1 INTRODUCTION

A DC–AC converter is commonly known as an inverter. The input to an inverter is DC, and the output is AC. The power semiconductor devices perform the switching action, and the desired output is obtained by varying their turn-on and turn-off times. They must have controllable turn-on and turn-off characteristics. The commonly used devices are BJTs, MOSFETs, IGBTs, GTOs, MCTs, and forced-commutated thyristors. We use PSpice switches, BJTs, and IGBTs to simulate the characteristics of the following inverters:

- Voltage-source inverters
- Current-source inverters

## 9.2 VOLTAGE-SOURCE INVERTERS

Two types of control are commonly used for varying the output of an inverter: PWM and sinusoidal pulse-width modulation (SPWM). The number of pulses per half cycle usually ranges from 1 to 15.

In PWM control, the conduction angles of power semiconductor devices are generated by comparing a reference signal  $v_r$  with a carrier signal  $v_c$ , as shown in [Figure 9.1](#). The pulse width  $\delta$  can be varied by changing the carrier voltage  $v_c$ . This technique can be implemented by a descending hierarchy as shown in [Figure 8.3\(b\)](#). The input voltages to the comparator are  $v_r$  and  $v_c$ , and its output is the conduction angle  $\delta$  for which the switch remains on. The modulation index  $M$  is defined by

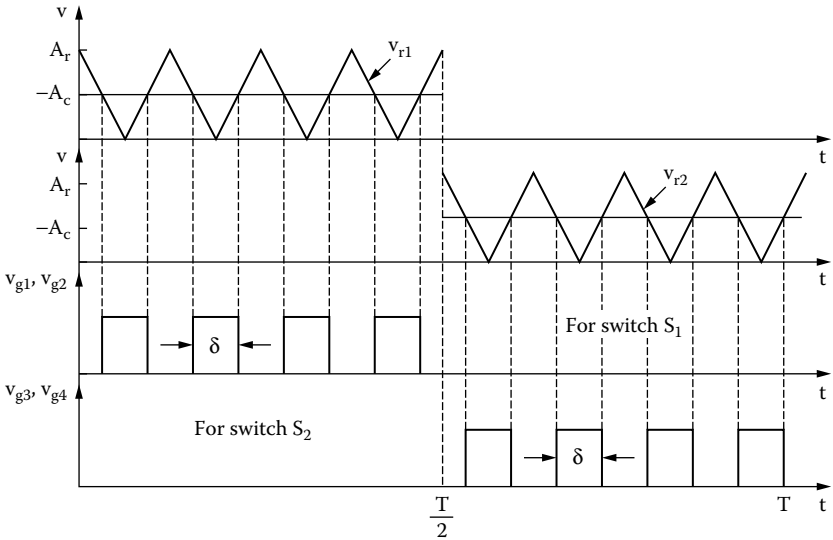


FIGURE 9.1 PWM control.

$$M = \frac{A_c}{A_r} \tag{9.1}$$

where  $A_r$  is the peak value of the reference signal  $v_r$ , and  $A_c$  is the peak value of the carrier signal  $v_c$ .

The PWM modulator can be used as a subcircuit to generate control signals for a triangular reference voltage of one or more pulses per half cycle and a DC carrier signal. The PSpice schematic for generating PWM control signals is shown in Figure 9.2(b).  $V_{ref}$  produces a pulse signal at a reference (or switching) frequency of  $f_s = p \times f_o$ , where  $p$  is the number of pulses per half cycle and  $f_o$  is the frequency of the output voltage. A DC carrier signal  $V_{cr}$  as shown in Figure 9.2(a) is compared with the reference signal  $V_{ref}$  by an ABM2 device as in Figure 9.2(b).  $V_{ref}$  is a triangular signal at the carrier frequency of  $f_c$ .  $V_x$  is a pulse signal at an output frequency of  $f_o$  at a 50% duty cycle, and it releases gating signals during the first half cycle of the output voltage.  $V_y$  is the logical inverse of  $V_x$ , i.e.,  $V_y = \overline{V_x}$ , and it releases gating signals during the second half cycle of the output voltage.  $g_1$  and  $g_3$  are the gating signals for switches  $S_1$  and  $S_3$ .

The subcircuit definition for the modulator model PWM can be described as follows:

```

* Subcircuit for PWM Control
.SUBCKT PWM      7      5      10      11 PARAMS: fout=60Hz p=4
*      Model  ref.   carrier +g1 control +g3 control
*      Name  signal signal voltage      voltage
    
```

```

* Where fout is the output frequency and p is the number of pulses
per half cycle
Vref 7 0 PULSE (1 0 0 {1/(2*{2*{p}*{fout}})}) {1/(2*{2*{p}*{fout}})-
1ns}1ns {1/{2*{p}*
+ {fout}}})      ; Reference voltage at output frequency
V_mod 5 0 0.6      ; Modulation index of less than 1.0
Vx 8 0 PULSE (0 1 0 1ns 1ns {1/(2*{fout}})-
2ns) {1/{fout}}) ; pulse at the output frequency
E_ABM21 6 0 VALUE {IF(V(5)-V(7)>0, 1, 0)}
E_ABM12 9 0 VALUE {1-V(8)}      ; Inverter
E_MULT1 10 0 VALUE {V(8)*V(6)} ; Multiplier 1
E_MULT2 11 0 VALUE {V(9)*V(6)} ; Multiplier 2
.ENDS PWM      ; Ends subcircuit definition
    
```

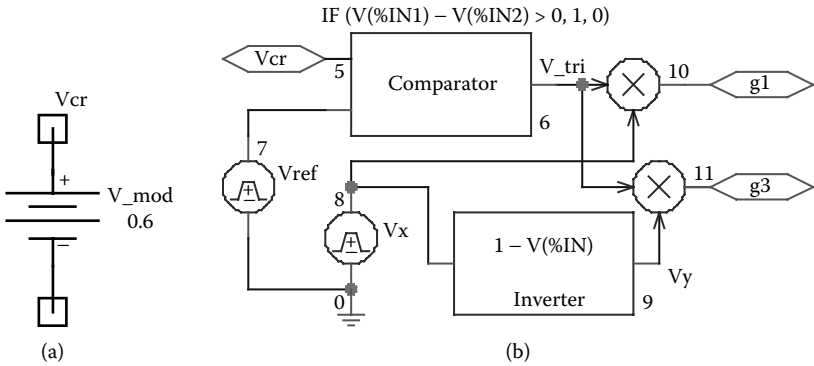


FIGURE 9.2 Schematics for PWM signals. (a) Carrier signal, (b) comparator.

In SPWM control, the carrier signal is a rectified sine wave as shown in Figure 9.3. PSpice generates only a sine wave. Thus, we can use a precision rectifier to convert a sine wave signal to rectified sine wave pulses and a comparator to generate a PWM waveform. This can be implemented using the circuit shown in Figure 9.4. Sinusoidal PWM signals are generated by replacing the DC carrier signal  $V_{cr}$  in Figure 9.2(a) with a rectified sinusoidal signal  $v_{cr} = |M \sin(2\pi f_o t)|$ , where  $M$  is the modulation index and  $f_o$  is the frequency of the output voltage. An ABS unit as shown in Figure 9.4(a) performs the rectification function and produces the sinusoidal carrier signal.  $V_{ref}$  is a triangular signal at the switching frequency of  $f_s$ .  $V_x$  is a pulse signal at an output frequency of  $f_o$  at a 50% duty cycle, and it releases gating signals during the first half cycle of the output voltage.  $V_y$  is the logical inverse of  $V_x$ , i.e.,  $V_y = \overline{V_x}$ , and it releases gating signals during the second half cycle of the output voltage.  $g_1$  and  $g_3$  as shown in Figure 9.4(b) are generated by the comparator and are the gating signals for switches  $S_1$  and  $S_3$ .

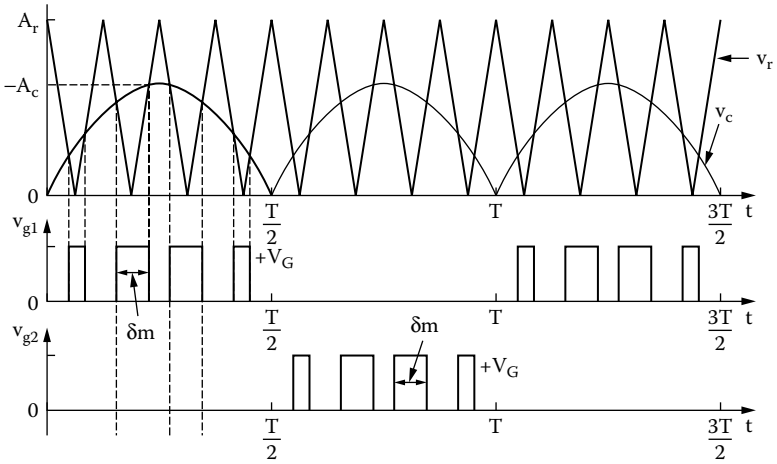


FIGURE 9.3 Gate voltages with a SPWM control.

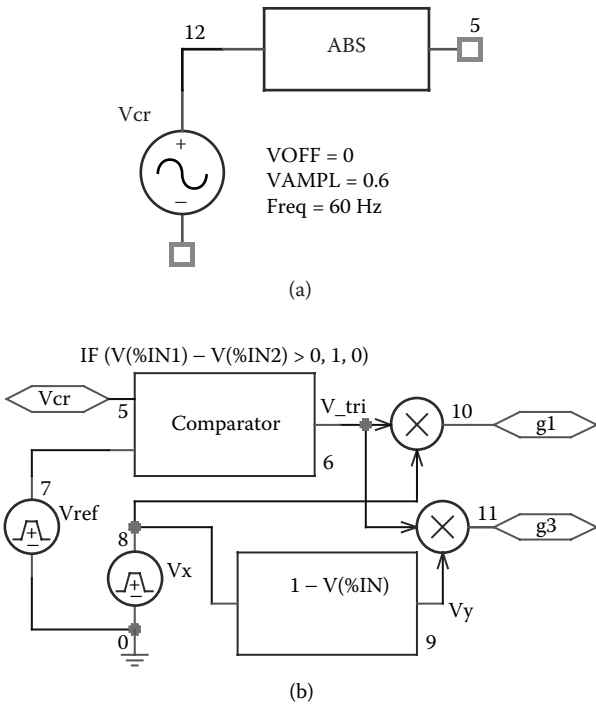


FIGURE 9.4 PSpice Schematics for SPWM signals. (a) Sinusoidal carrier signal, (b) comparator.

We can use a subcircuit SPWM for the generation of control signals. The subcircuit definition for the modulator model SPWM can be described as follows:

---

```
* Subcircuit for Sinusoidal PWM Control
.SUBCKT SPWM 7 5 10 11 PARAMS: fout=60Hz p=4
*      Model ref.  carrier +g1 control +g3 control
*      Name signal signal voltage voltage
* Where fout is the output frequency and p is the number of pulses
per half cycle
Vref 7 0 PULSE 1 0 0 {1/(2*{2*{p}*{fout}})} {1/(2*{2*{p}*{fout}})-
1ns} 1ns {1/(2*{p}*
+ {fout})} ; Reference voltage at output frequency
V_mod 12 0 SIN (0 0.6 60Hz) ; Modulation index of less than 1.0
V_mod 12 5
Vx 8 0 PULSE (0 1 0 1ns 1ns {1/(2*{fout})-2ns} {1/{fout}}) ; pulse
at the output frequency

E_ABM21 6 0 VALUE {IF(V(5)-V(7)>0, 1, 0)}
E_ABM12 9 0 VALUE {1-V(8)} ; Inverter
E_MULT1 10 0 VALUE {V(8)*V(6)} ; Multiplier 1
E_MULT2 11 0 VALUE {V(9)*V(6)} ; Multiplier 2
.ENDS SPWM
```

---

### EXAMPLE 9.1 FINDING THE PERFORMANCE OF A SINGLE-PHASE INVERTER WITH VOLTAGE-CONTROLLED SWITCHES

A single-phase bridge inverter is shown in [Figure 9.5](#). The DC input voltage is 100 V. It is operated at an output frequency of  $f_o = 60$  Hz with PWM control and four pulses per half cycle. The modulation index  $M = 0.6$ . The load is purely resistive with  $R = 2.5 \Omega$ . Use PSpice to (a) plot the instantaneous output voltage  $v_o$ , the instantaneous carrier and reference voltages and (b) calculate the Fourier coefficients of output voltage  $v_o$ . Use voltage-controlled switches to perform the switching action.

#### SOLUTION

$P = 4$ ,  $M = 0.6$ . Assuming that  $A_r = 10$  V,  $A_c = 10 \times 0.6 = 6$  V. We can model a power device as a voltage-controlled switch as shown in [Figure 9.6](#). The subcircuit definition for the switched transistor model (STMOD) can be described as follows:

---

```
* Subcircuit for switched transistor model:
.SUBCKT STMOD 1 2 3 4
*      model anode cathode +control -control
*      name voltage voltage
DT 5 2 DMOT ; Switch diode
ST 1 5 3 4 SMOD ; Switch
.MODEL DMOT D(IS=2.2E-15 BV=1200V CJO=0 TT=0) ; Diode model parameters
.MODEL SMOD VSWITCH RON = 0.01 ROFF = 10E+6 VON = 10V VOFF=5V)
.ENDS STMOD ; Ends subcircuit definition
```

---

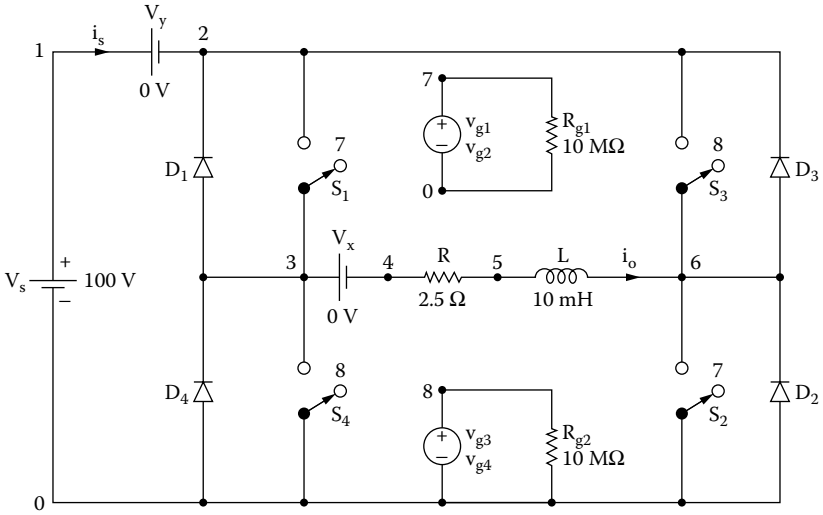


FIGURE 9.5 Single-phase bridge inverter.

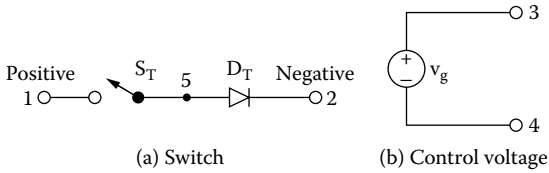


FIGURE 9.6 Switched transistor model.

We can use the subcircuit PWM in Figure 9.1 for the generation of control signals. The PSpice schematic is shown in Figure 9.7(a). By varying the modulation voltage  $V_{mod}$  (or carrier signal  $V_{cr}$ ) from 0.01 to 0.99 V, the on time of a switch and the output voltage can be changed. The comparator subcircuit for the PWM block is shown in Figure 9.7(b). The model parameters for the switch and the freewheeling diode are as follows:

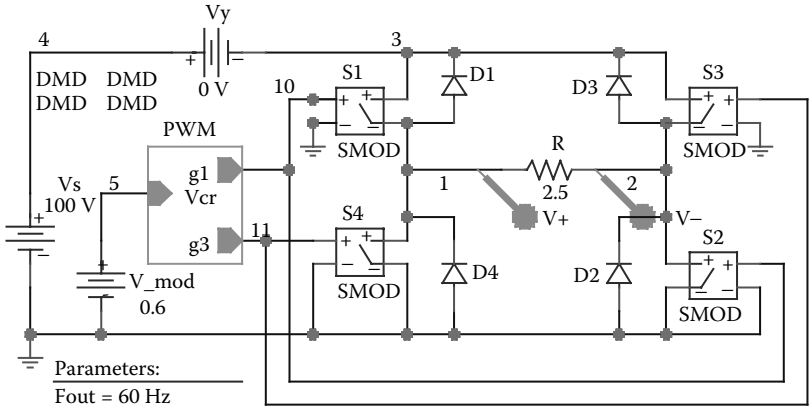
```
.MODEL SMD VSWITCH (RON=1M ROFF=10E6 VON=1V VOFF=0V)
for switches

.MODEL DMD D (IS=2.22E-15 BV=1200V CJO=1PF TT=0US)
for diodes
```

The listing of the circuit file for the inverter is as follows:

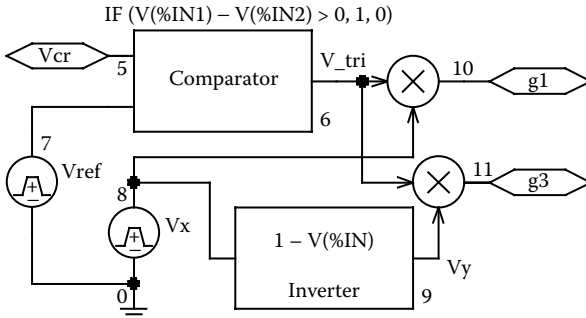
**Example 9.1 Single-phase inverter with PWM control**

```
Vs 4 0 100V ; DC input voltage
Vy 4 3 0V ; Monitors input current
```



Parameters:  
 Fout = 60 Hz  
 P = 4

(a)



(b)

**FIGURE 9.7** PSpice schematic for Example 9.1. (a) Schematic, (b) descending hierarchy comparator.

```
V_mod 5 0 0.6 ; Modulation index of less than 1.0
.PARAM fout=60Hz p=4 ; parameters
* Parameters: fout = output frequency and p = # of pulses per half
  cycle
S1 3 1 10 0 SMD ; Voltage-controlled switches with SMD
S2 2 0 10 0 SMD
S3 3 2 11 0 SMD
S4 1 0 11 0 SMD
D1 1 3 DMD ; Diodes with model DMD
D2 0 2 DMD
D4 0 1 DMD
D3 2 3 DMD
R 1 2 2.5
```

```
.MODEL DMD D(IS=2.2E-15 BV=1800V TT=0) ; Diode model parameters
* Switch model parameters
.MODEL SMD VSWITCH (RON=0.01 ROFF=10E+6 VON=1V VOFF=0V)
E_ABM21 6 0 VALUE {IF(V(5)-V(7)>0, 1, 0)}
Vx 8 0 PULSE (0 1 0 1ns 1ns {1/(2*{fout})}-
2ns) {1/{fout}}) ; pulse at the output frequency
Vref 7 0
+PULSE (1 0 0 {1/(2*{2*{p}*{fout}})} {1/(2*{2*{p}*{fout}})}-
1ns) 1ns {1/{2*{p}*
+ {fout}}) ; Reference voltage at output frequency
E_ABM12 9 0 VALUE {1-V(8)} ; Inverter
E_MULT1 10 0 VALUE {V(8)*V(6)} ; Multiplier 1
E_MULT2 11 0 VALUE {V(9)*V(6)} ; Multiplier 2
.TRAN 1US 16.67MS 0 0.1US ; Transient Analysis
.FOUR 60Hz 10 V(1,2) ; Fourier Analysis
.OPTIONS ABSTOL=1UA RELTOL=0.1 VNTOL=0.1
.PROBE
.END
```

The conduction angles are generated from two reference signals as shown in [Figure 9.8](#). Assume that the reference voltage  $V_r = 1$  V. For  $M = 0.4$ , the carrier voltage is  $V_c = MV_r = 0.4$  V.

Note the following:

- The PSpice plots of the instantaneous output voltage  $V(1,2)$ , the instantaneous carrier voltages, and the instantaneous reference voltage are shown in [Figure 9.8](#).
- The Fourier coefficients of the output voltage are as follows:

---

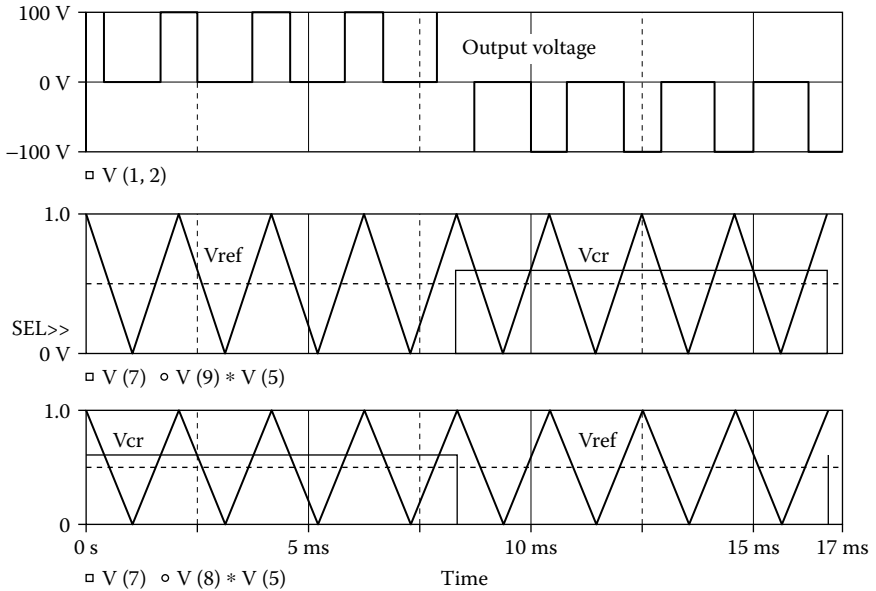
### FOURIER COMPONENTS OF TRANSIENT RESPONSE V (3,6)

DC COMPONENT = 8.339770E-04

Harmonic No	Frequency (Hz)	Fourier Component	Normalized Component	Phase (Deg)	Normalized Phase (Deg)
1	6.000E+01	7.449E+01	1.000E+00	-2.945E-02	0.000E+00
2	1.200E+02	1.720E-03	2.310E-05	1.596E+02	1.597E+02
3	1.800E+02	2.871E+01	3.855E-01	-1.179E-01	-8.846E-02
4	2.400E+02	1.852E-03	2.486E-05	-1.307E+02	-1.307E+02
5	3.000E+02	2.472E+01	3.318E-01	2.240E-02	5.185E-02
6	3.600E+02	1.994E-03	2.677E-05	-5.965E+01	-5.962E+01
7	4.200E+02	4.608E+01	6.186E-01	6.028E-01	6.323E-01
8	4.800E+02	2.076E-03	2.787E-05	1.365E+01	1.368E+01
9	5.400E+02	3.132E+01	4.205E-01	-1.791E+02	-1.790E+02

TOTAL HARMONIC DISTORTION = 9.044873E+01PERCENT

---



**FIGURE 9.8** Plots for Example 9.1.

*Note:* Because voltage-controlled switches will allow bidirectional current flow, they will produce the correct output voltage with a resistive load only.

### EXAMPLE 9.2 FINDING THE PERFORMANCE OF A SINGLE-PHASE PWM INVERTER WITH AN $RL$ LOAD

The PWM inverter in Example 9.1 has a load resistance  $R = 2.5 \Omega$ , and a load inductance  $L = 10 \text{ mH}$ . Use PSpice to (a) plot the instantaneous output voltage  $v_o$ , the instantaneous output current  $i_o$ , and the instantaneous supply current  $i_s$  and (b) calculate the Fourier coefficients of the output voltage  $v_o$  and the output current  $i_o$ .

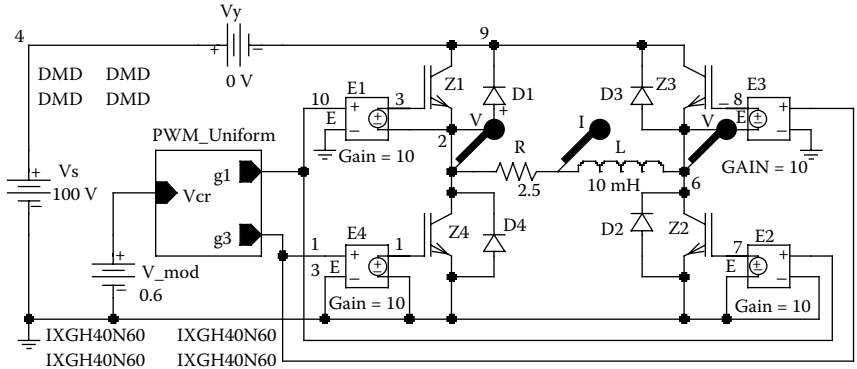
### SOLUTION

Because a load inductance will cause a bidirectional current flow through the load, we will use unidirectional switching devices such as IGBTs. The PSpice schematic is shown in Figure 9.9(a). By varying the modulation voltage  $V_{\text{mod}}$  from 0.01 to 0.99 V, the conduction time of the IGBTs and the output voltage can be changed. The comparator subcircuit for the PWM block is shown in Figure 9.9(b). The model parameters for IGBTs and freewheeling diodes are as follows:

```
.MODEL IXGH40N60 (TAU=287.56NS KP=50.034 AREA=37.5U AGD=18.75U
```

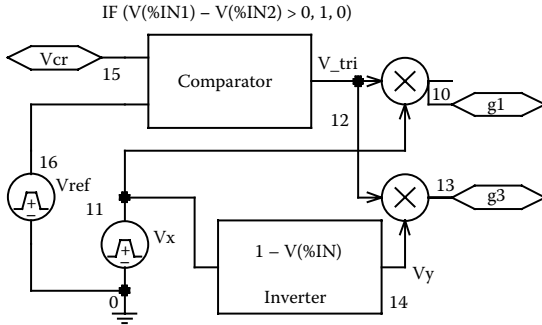
```
+ VT=4.1822 KF=.36047 CGS=31.942NF COXD=53.188NF VTD=2.6570) for IGBTs
```

```
.MODEL DMD D (IS=2.22E-15 BV=1200V CJO=1PF TT=0US) for diodes
```



Parameters:  
 Fout = 60 Hz  
 P = 4

(a)



(b)

**FIGURE 9.9** PSpice schematic for Example 9.2. (a) Schematic, (b) descending hierarchy comparator.

The listing of the circuit file is changed as follows:

**Example 9.2 Single-phase inverter with PWM control**

```

Vs 4 0 100V ; DC input voltage
Vy 4 9 0V ; Monitors input current
V_mod 15 0 0.6 ; Modulation index of less than 1.0
.PARAM Fout=60Hz P=4
* Parameters: fout = output frequency and p = # of pulses per half
cycle
Z1 9 3 2 IXGH40N60 ; IGBTs with a model IXGH40N60
Z2 6 7 0 IXGH40N60
Z3 9 8 6 IXGH40N60
Z4 2 1 0 IXGH40N60
    
```

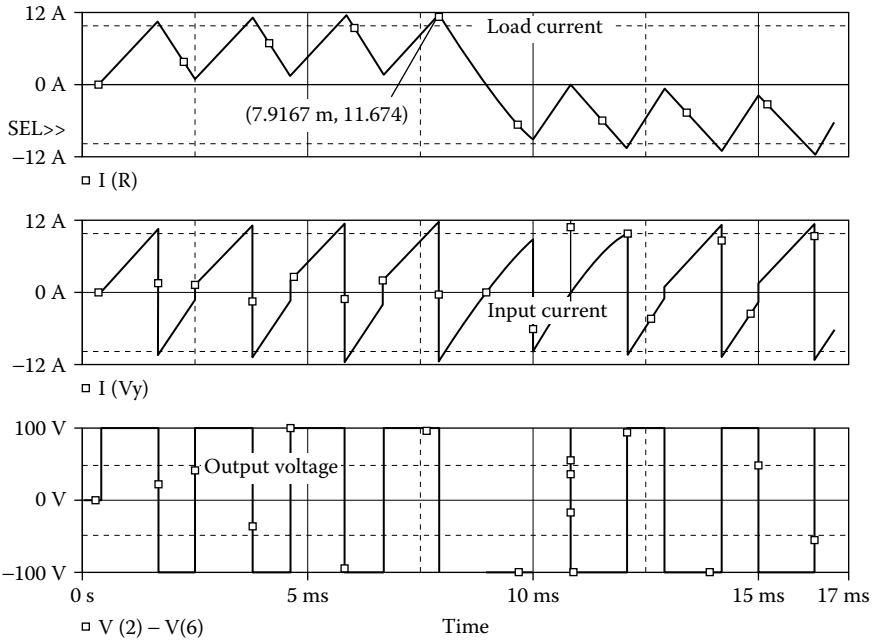


FIGURE 9.10 Plots for Example 9.2.

```
.MODEL IXGH40N60 NIGBT (TAU=287.56ns KP=50.034 AREA=37.5um AGD=18.7
5um
+ VT=4.1822 KF=.36047 CGS=31.942nf COXD=53.188nf VTD=2.6570)
D1 2 9 DMD ; Diodes with model DMD
D2 0 6 DMD
D3 6 9 DMD
D4 0 2 DMD
.MODEL DMD D(IS=2.2E-15 BV=1800V TT=0) ; Diode model parameters
E1 3 2 10 0 10 ; Voltage controlled voltage source
E2 7 0 10 0 10
E3 8 6 13 0 10
E4 1 0 13 0 10
R 2 5 2.5 ; Load resistance
L 5 6 10mH ; Load inductance
Vref 16 0 PULSE (1 0 0 {1/(2*{2*{p}*{fout}})}) {1/(2*{2*{p}*
{fout}})-1ns} 1ns
+ {1/{2*{p}*{fout}}})
```

```

Vx 11 0 PULSE (0 1 0 1ns 1ns {1/(2*{fout})-2ns} {1/{fout}})
E_MULT1 10 0 VALUE {V(11)*V(12)} ; Multiplier 1
E_MULT2 13 0 VALUE {V(14)*V(12)} ; Multiplier 2
E_ABM21 12 0 VALUE {IF(V(15)-V(16)>0, 1, 0)} ; Comparator
E_ABM12 14 0 VALUE {1-V(11)} ; Inverter
.TRAN 1US 16.67MS 0 0.1US ; Transient Analysis
.FOUR 60Hz 10 V(1,2) I(Vy) ; Fourier Analysis
.OPTIONS ABSTOL=1uA CHGTOL=0.1uC RELTOL=0.1 VNTOL=0.1
.PROBE
.END

```

Note the following:

- The PSpice plots of the instantaneous output voltage  $V(2,6)$ , the output current  $I(R)$ , and the supply current  $I(VY)$  are shown in [Figure 9.10](#).
- The Fourier coefficients of the output voltage and the output current are as follows:

---

### FOURIER COMPONENTS OF TRANSIENT RESPONSE V (3,6)

DC COMPONENT =  $-7.146290E-02$

Harmonic No	Frequency (Hz)	Fourier Component	Normalized Component	Phase (Deg)	Normalized Phase (Deg)
1	6.000E+01	3.267E+01	1.000E+00	6.813E+01	0.000E+00
2	1.200E+02	1.267E-01	3.879E-03	-1.364E+02	-2.045E+02
3	1.800E+02	2.885E+01	8.831E-01	1.298E+02	6.168E+01
4	2.400E+02	1.155E-01	3.535E-03	1.703E+02	1.021E+02
5	3.000E+02	3.777E+01	1.156E+00	1.736E+02	1.055E+02
6	3.600E+02	1.202E-01	3.679E-03	1.140E+02	4.591E+01
7	4.200E+02	8.850E+01	2.709E+00	-1.471E+02	-2.153E+02
8	4.800E+02	1.341E-01	4.103E-03	6.515E+01	-2.979E+00
9	5.400E+02	6.730E+01	2.060E+00	6.753E+01	-5.927E-01

TOTAL HARMONIC DISTORTION =  $3.700917E+02$ PERCENT

---

### FOURIER COMPONENTS OF TRANSIENT RESPONSE I(R)

DC COMPONENT =  $3.288993E-01$

Harmonic No	Frequency (Hz)	Fourier Component	Normalized Component	Phase (Deg)	Normalized Phase (Deg)
1	6.000E+01	7.469E+00	1.000E+00	-1.394E+01	0.000E+00
2	1.200E+02	2.804E-01	3.754E-02	4.549E+01	5.942E+01
3	1.800E+02	2.535E+00	3.395E-01	-2.891E+01	-1.497E+01

Harmonic No	Frequency (Hz)	Fourier Component	Normalized Component	Phase (Deg)	Normalized Phase (Deg)
4	2.400E+02	1.832E-01	2.453E-02	4.369E+01	5.762E+01
5	3.000E+02	1.946E+00	2.605E-01	-4.735E+01	-3.341E+01
6	3.600E+02	1.489E-01	1.994E-02	4.922E+01	6.316E+01
7	4.200E+02	3.264E+00	4.370E-01	-7.088E+01	-5.694E+01
8	4.800E+02	1.471E-01	1.969E-02	5.020E+01	6.414E+01
9	5.400E+02	2.088E+00	2.796E-01	8.048E+01	9.442E+01
TOTAL HARMONIC DISTORTION = 6.745586E+01 PERCENT					

Note: With an inductive load, the output voltage V(2,3) switches between the -Vs to +Vs to adjust to the load current I(R), which rises and falls.

**EXAMPLE 9.3 FINDING THE PERFORMANCE OF A SINGLE-PHASE SPWM INVERTER**

Repeat Example 9.1 with SPWM control.

**SOLUTION**

$P = 4$ ,  $M = 0.6$ . Let us assume that  $A_r = 10$  V. Also,  $A_c = 10 \times 0.6 = 6$  V. The two reference voltages are generated with a PWL function as shown in Figure 9.8. A precision rectifier can also convert a sine wave input signal to two half-sine-wave pulses, and a comparator generates the PWM waveform. This is shown in Figure 9.12. We can use the subcircuit SPWM for generation of the control signals. IGBTs are used as switching devices in the PSpice schematic shown in Figure 9.11, which is similar to Figure 9.9(a). The carrier signal is a rectified sinusoidal waveform, as shown in Figure 9.2(a), of the form  $v_{cr} = |M \sin(2\pi f_o t)|$ , where  $M$  is the modulation index and  $f_o$  is the frequency of the output voltage. The listing of the circuit file for

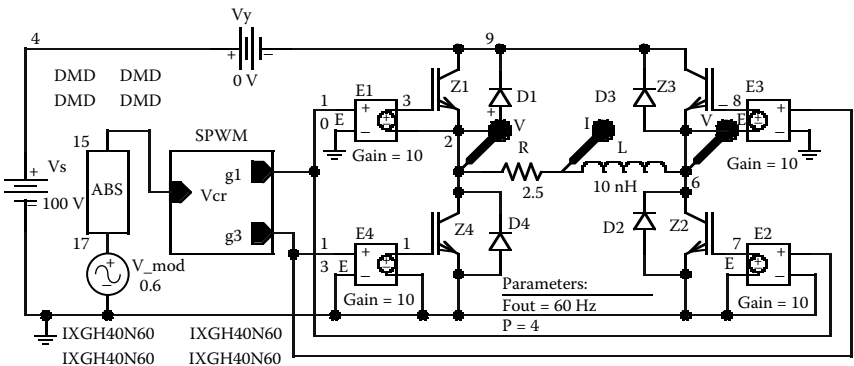


FIGURE 9.11 PSpice schematic for Example 9.3.

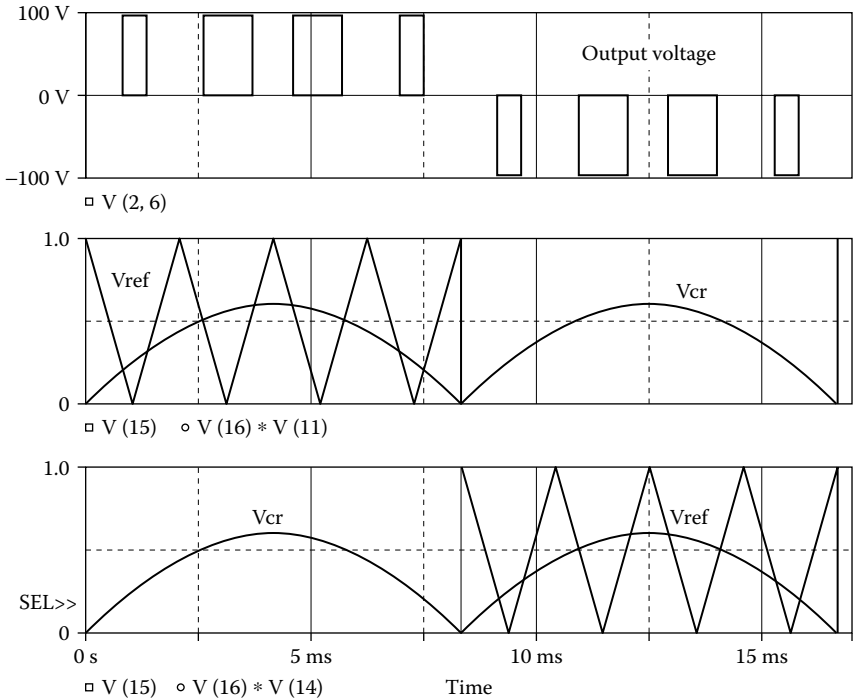


FIGURE 9.12 Plots for Example 9.3.

the inverter in Example 9.2 can be changed to modify the modulating signal as follows:

```
V_mod 17 0 AC 0SIN (0 {M} {fout} 0 0 0)
E_ABS 15 0 VALUE {ABS(V(17))}
```

Note the following.

- (a) The PSpice plots of the instantaneous output voltage  $V(2,6)$ , the carrier voltages, and the reference voltages are shown in Figure 9.12.
- (b) The Fourier coefficients of the output voltage are as follows:

*Note:* With an inductive load, the output voltage will contain switching transients due to the switching times of the IGBTs and diodes. By varying the modulation voltage  $V_{cr}$ , or modulation index  $M$ , from 0.01 to 0.99 V, the conduction time of the IGBTs and the output voltage can be changed.

**EXAMPLE 9.4 FINDING THE PERFORMANCE OF A THREE-PHASE PWM INVERTER**

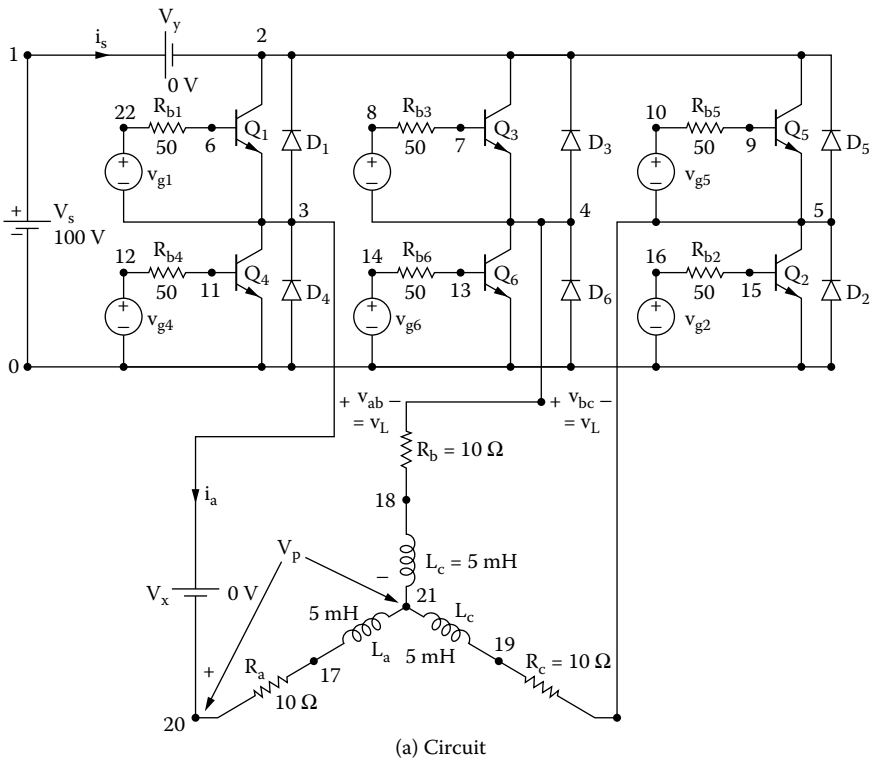
A three-phase bridge inverter is shown in Figure 9.13(a). The DC input voltage is 100 V. The control voltages are shown in Figure 9.13(b). The output frequency is

**FOURIER COMPONENTS OF TRANSIENT RESPONSE V (3, 6)**

DC COMPONENT =  $-4.386737E-03$

Harmonic No	Frequency (Hz)	Fourier Component	Normalized Component	Phase (Deg)	Normalized Phase (Deg)
1	6.000E+01	5.734E+01	1.000E+00	2.895E+01	0.000E+00
2	1.200E+02	1.233E-02	2.150E-04	-5.973E+01	-8.868E+01
3	1.800E+02	2.328E-02	4.061E-04	-1.778E+01	-4.673E+01
4	2.400E+02	1.630E-02	2.842E-04	-5.811E+01	-8.706E+01
5	3.000E+02	6.256E+00	1.091E-01	1.427E+02	1.137E+02
6	3.600E+02	1.604E-02	2.798E-04	-6.504E+01	-9.399E+01
7	4.200E+02	3.599E+01	6.278E-01	-1.583E+02	-1.873E+02
8	4.800E+02	1.197E-02	2.087E-04	-7.286E+01	-1.018E+02
9	5.400E+02	3.616E+01	6.307E-01	7.955E+01	5.060E+01

TOTAL HARMONIC DISTORTION =  $8.965353E+01$  PERCENT



**FIGURE 9.13** Three-phase bridge inverter. (a) Circuit, (b) control voltages.



FIGURE 9.13 (continued).

$f_0 = 1$  kHz. The load resistance is  $R = 10 \Omega$ , and the load inductance is  $L = 5$  mH. Use PSpice to (a) plot the instantaneous output line–line voltage  $v_L$ , the instantaneous output phase voltage  $v_p$ , and the instantaneous output current  $i_a$  for phase  $a$  and (b) calculate the Fourier coefficients of the phase voltage  $v_p$  and the phase current  $i_a$ . The model parameters of the BJTs are  $IS = 2.33E27$ ,  $BF = 13$ ,  $CJE = 1PF$ ,  $CJC = 607.3PF$ , and  $TF = 26.5NS$ .

### SOLUTION

BJTs are used as switching devices in the PSpice schematic shown in Figure 9.14.

The listing of the circuit file for the inverter is as follows:

### EXAMPLE 9.4 Three-phase inverter with PWM control

```
.PARAM Freq=1kHz ; * Parameters: Freq = output frequency
Vs 15 0 100V ; DC input voltage
Vy 15 6 0V ; Monitors input current
Vx 5 19 0V ; Monitors output phase current
Rb1 22 21 50
Vg1 22 5 PULSE (0 40 0 1ns 1ns {1/(2*{Freq})-2ns} {1/{Freq}})
Rb2 9 12 50
Vg2 9 0 PULSE (0 40 {1/(6*{Freq})} 1ns 1ns {1/(2*{Freq})-2ns}
{1/{Freq}})
Rb3 1 11 50
Vg3 1 2 PULSE (0 40 {2/(6*{Freq})} 1ns 1ns {1/(2*{Freq})-2ns}
{1/{Freq}})
```

```

Rb4 7 13 50
Vg4 7 0 PULSE (0 40 {3/(6*{Freq})} 1ns 1ns {1/(2*{Freq})-2ns}
{1/{Freq}})
Rb5 3 10 50
Vg5 3 4 PULSE (0 40 {4/(6*{Freq})} 1ns 1ns {1/(2*{Freq})-2ns}
{1/{Freq}})
Rb6 8 14 50
Vg6 8 0 PULSE (0 40 {5/(6*{Freq})} 1ns 1ns {1/(2*{Freq})-2ns}
{1/{Freq}})
D1 5 6 DMD ; Diodes with model DMD
D2 0 4 DMD
D3 2 6 DMD
D4 0 5 DMD
D5 4 6 DMD
D6 0 2 DMD
.MODEL DMD D(IS=2.2E-15 BV=1800V TT=0) ; Diode model parameters
Q1 6 21 5 QMOD ; BJTs with model QMOD
Q5 6 10 4 QMOD
Q3 6 11 2 QMOD
Q2 4 12 0 QMOD
Q4 5 13 0 QMOD
Q6 2 14 0 QMOD
.MODEL QMOD NPN(IS=6.83E-14 BF=13 CJE=1pF CJC=607.3PF TF=26.5NS
La 18 17 5mH ; Load inductance for phase a
Ra 19 18 10 ; Load resistance for phase a
Rb 16 2 10
Lb 17 16 5mH
Rc 20 4 10
Lc 17 20 5mH
.TRAN 0.1US 2.5MS 1MS 0.1e-6 ; Transient Analysis
.OPTIONS ABSTOL=1uA CHGTOL=0.01nC ITL2=100 ITL4=150 RELTOL=0.1
VNTOL=0.1
.PROBE
.END

```

---

Note the following:

- (a) The PSpice plots of the instantaneous output line–line voltages  $V(3, 4)$ ,  $V(4, 5)$ , and  $V(5, 3)$  are shown in [Figure 9.15](#). The output phase voltages  $V(3.21)$

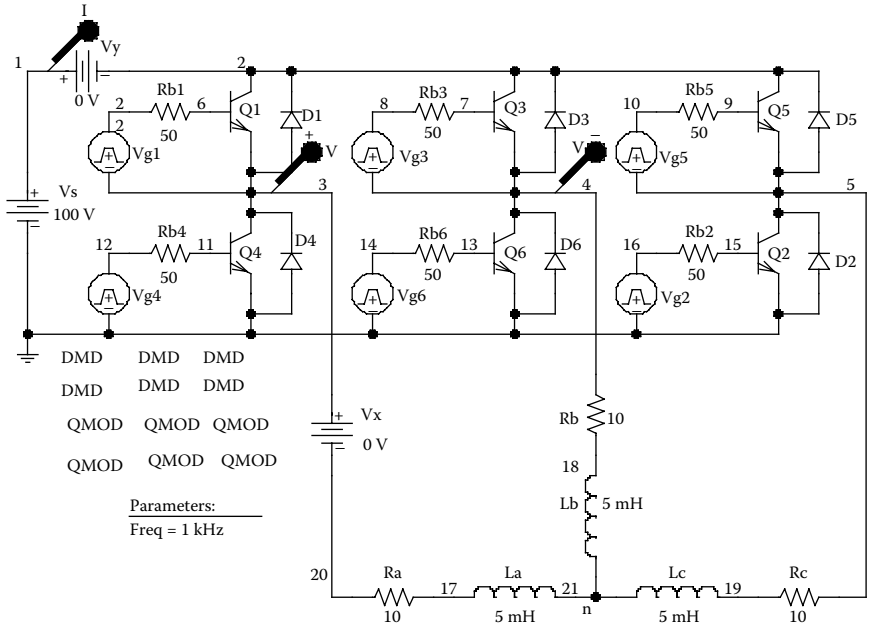


FIGURE 9.14 PSpice schematic for Example 9.4.

and  $V(4, 21)$  and the output phase current  $I(VX)$  are shown in Figure 9.16. The phase current is almost sinusoidal with THD = 4.72%.

- (b) The Fourier coefficients of the output phase voltage and phase current are as follows:

**FOURIER COMPONENTS OF TRANSIENT RESPONSE V(3,21)**

DC COMPONENT = -3.689844E-03

Harmonic No	Frequency (Hz)	Fourier Component	Normalized Component	Phase (Deg)	Normalized Phase (Deg)
1	1.000E+03	6.349E+01	1.000E+00	1.796E+02	0.000E+00
2	2.000E+03	2.118E-02	3.336E-04	1.098E+02	-6.981E+01
3	3.000E+03	6.643E-01	1.046E-02	8.981E+01	-8.979E+01
4	4.000E+03	2.138E-02	3.368E-04	-6.049E+01	-2.401E+02
5	5.000E+03	1.306E+01	2.057E-01	1.775E+02	-2.135E+00
6	6.000E+03	6.534E-03	1.029E-04	1.216E+02	-5.799E+01
7	7.000E+03	9.015E+00	1.420E-01	1.759E+02	-3.683E+00
8	8.000E+03	1.352E-02	2.129E-04	-1.845E+01	-1.980E+02
9	9.000E+03	6.873E-01	1.083E-02	8.654E+01	-9.305E+01

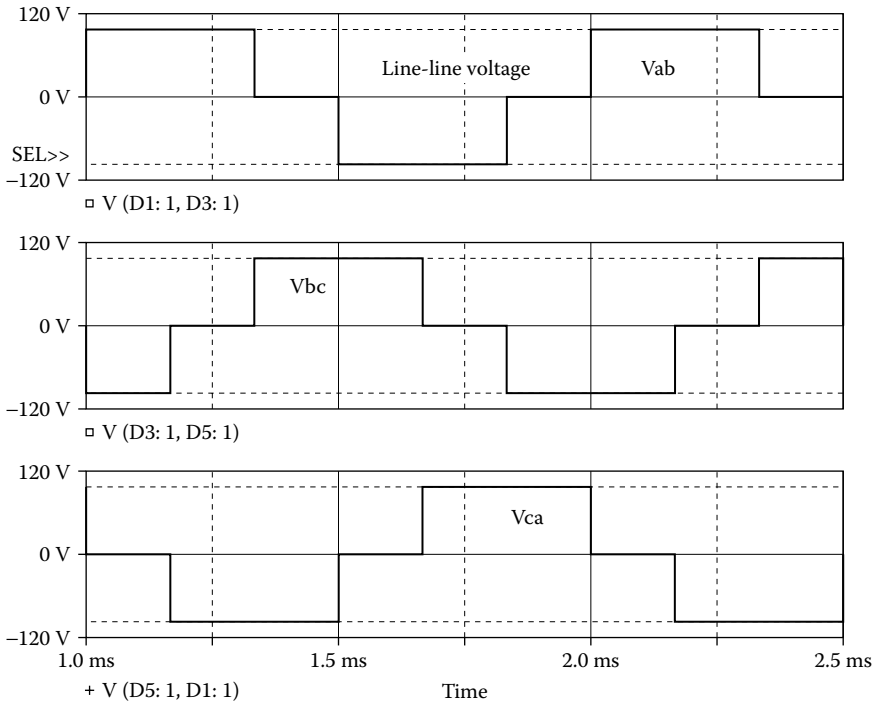
TOTAL HARMONIC DISTORTION = 2.503806E+01 PERCENT

**FOURIER COMPONENTS OF TRANSIENT RESPONSE I(VX)**

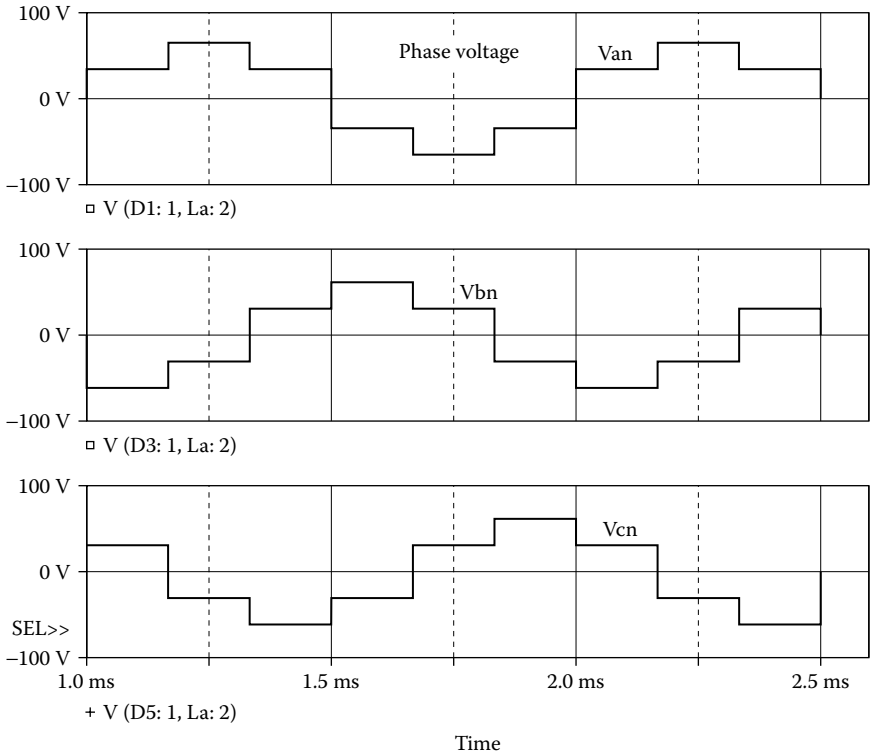
DC COMPONENT =  $-4.969840E-03$

Harmonic No	Frequency (Hz)	Fourier Component	Normalized Component	Phase (Deg)	Normalized Phase (Deg)
1	1.000E+03	1.931E+00	1.000E+00	1.078E+02	0.000E+00
2	2.000E+03	8.719E-04	4.516E-04	-1.507E+02	-2.586E+02
3	3.000E+03	4.645E-04	2.406E-04	1.384E+02	3.053E+01
4	4.000E+03	8.019E-04	4.153E-04	1.741E+02	6.625E+01
5	5.000E+03	8.075E-02	4.182E-02	9.345E+01	-1.439E+01
6	6.000E+03	4.428E-04	2.293E-04	-1.476E+02	-2.555E+02
7	7.000E+03	4.190E-02	2.170E-02	9.405E+01	-1.380E+01
8	8.000E+03	2.887E-04	1.495E-04	1.744E+02	6.659E+01
9	9.000E+03	2.040E-04	1.057E-04	1.227E+02	1.488E+01

TOTAL HARMONIC DISTORTION =  $4.711973E+00$  PERCENT



**FIGURE 9.15** Plots for Example 9.4.



**FIGURE 9.16** Plots for Example 9.4.

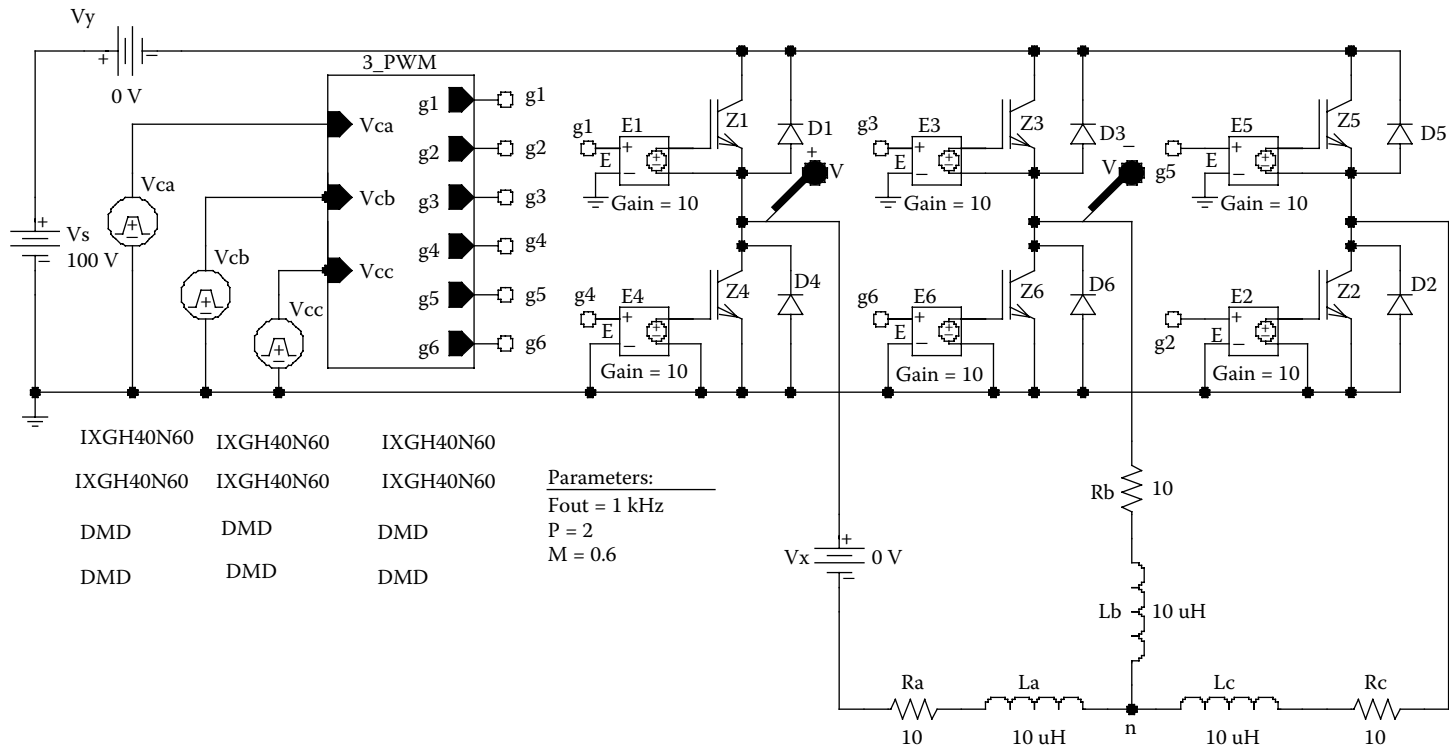
*Note:* The peak value of the line voltage varies between  $+V_s$  to  $-V_s$ , and that of the phase voltage varies between  $+2V_s/3$  to  $-2V_s/3$ . Each phase is shifted by  $120^\circ$  from the other.

**EXAMPLE 9.5 FINDING THE PERFORMANCE OF A THREE-PHASE UNIFORM PULSE PWM INVERTER**

Plot the output voltage and the gating signals  $g_1$  and  $g_3$  of the three-phase inverter in Figure 9.13(a) with two pulses per half cycle,  $p = 2$ , and a modulation index of  $M = 0.6$ . Assume uniform pulse modulation.

**SOLUTION**

IGBTs are used as switching devices in the PSpice schematic shown in Figure 9.17(a). The gating signal  $g_1$  is generated by comparing triangular reference signal  $V_{ref}$  of  $+1V$  to  $-1V$  with a carrier pulse signal of magnitude  $\{+M\}$  to  $\{-M\}$  having a 50% duty cycle at the frequency  $f_o$  of the output voltage. The switching frequency  $f_s$  is related to the output frequency  $f_o$  by  $f_s = 2 \times p \times f_o$ . The signal  $g_3$  is generated from  $V_{cb}$ , which is phase-shifted by  $120^\circ$  from  $V_{ca}$ . The PSpice schematic for implementation of the PWM waveform is shown in Figure 9.17(b).



(a)

FIGURE 9.17 Schematics for Example 9.5. (a) Schematic, (b) three-phase PWM generator.

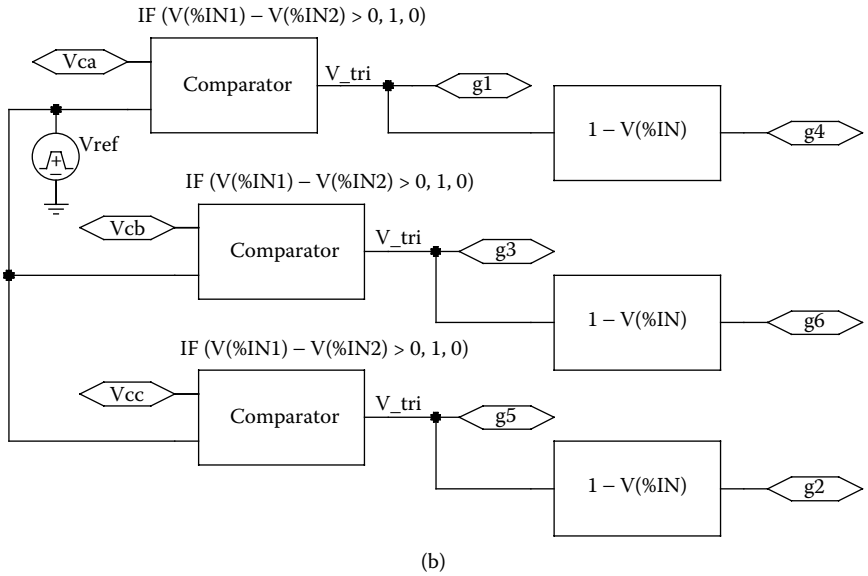


FIGURE 9.17 (continued).

The generation of the gate signals  $g_1$  and  $g_3$  is shown in Figure 9.18. The instantaneous line-to-line output voltages are  $V_{ab} = V_s(g_1 - g_3)$ ,  $V_{bc} = V_s(g_3 - g_5)$ , and  $V_{ca} = V_s(g_5 - g_1)$ . The line-line voltage  $V_{ab}$  is also shown in Figure 9.18, which is  $V_{ab} = V_s(g_1 - g_3)$ .

*Note:* The presence of  $g_3$  limits the duration of  $g_1$ , thereby causing notches in the output voltage. For example, we have specified two pulses per half cycle ( $p = 2$ ), but the output voltage has 3 pulses per half cycle as shown in Figure 9.18.

**EXAMPLE 9.6 FINDING THE PERFORMANCE OF A THREE-PHASE SINUSOIDAL PWM INVERTER**

Plot the output voltage and the gating signals  $g_1$  and  $g_3$  of the three-phase inverter in Figure 9.13(a) with two pulses per half cycle,  $p = 2$ , and a modulation index of  $M = 0.6$ . Assume sinusoidal pulse modulation.

**SOLUTION**

IGBTs are used as switching devices in the PSpice schematic shown in Figure 9.19. The gating signal  $g_1$  is generated by comparing triangular reference signal  $V_{ref}$  of +1V to -1V with a sinusoidal carrier signal  $V_{ca}$  of magnitude  $\{+M\}$  at the frequency  $f_o$  of the output voltage such that  $v_{cr} = M \sin(2\pi f_o t)$ . The switching frequency  $f_s$  is related to the output frequency  $f_o$  by  $f_s = 2 \times p \times f_o$ . The signal  $g_3$  is generated from  $V_{cb}$ , which is phase-shifted by  $120^\circ$  from  $V_{ca}$ . The PSpice schematic for implementation of the PWM waveform is shown in Figure 9.17(b).

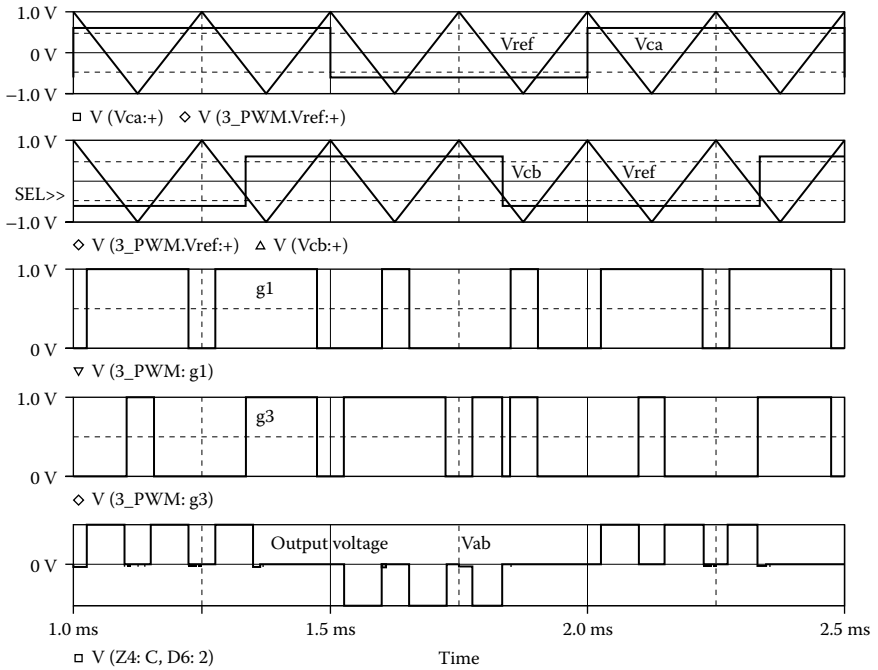


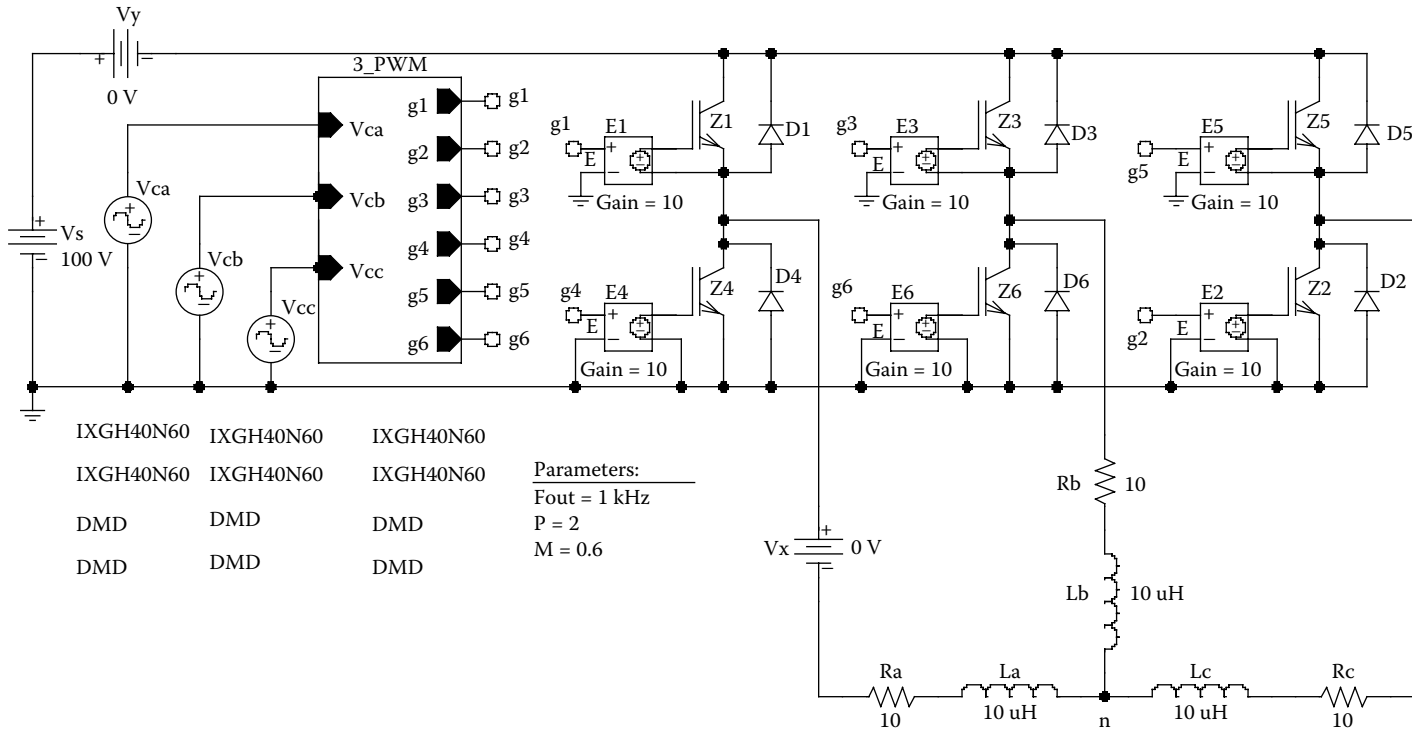
FIGURE 9.18 Plots for Example 9.5.

The generation of the gate signals  $g_1$  and  $g_3$  is shown in Figure 9.20. The instantaneous line-to-line output voltages are  $V_{ab} = V_s(g_1 - g_3)$ ,  $V_{bc} = V_s(g_3 - g_5)$ , and  $V_{ca} = V_s(g_5 - g_1)$ . The line-line voltage  $V_{ab}$  is also shown in Figure 9.20 and is given by  $V_{ab} = V_s(g_1 - g_3)$ .

*Note:* Because of the sinusoidal PWM, the middle pulse is the widest. The gate signal  $g_3$  produces notches. We have specified two pulses per half cycle ( $p = 2$ ), but the output voltage has four pulses per half cycle as shown in Figure 9.20.

### 9.3 CURRENT-SOURCE INVERTERS

The input current of a current-source inverter is maintained approximately constant by having a large inductor at the input side. The magnitude of this current is normally varied by a chopper with an output filter. The time during which the input source current flows through the load is controlled by varying the turn-on and turn-off times of the inverter switches. The control can also use PWM, SPWM, and other advanced modulation techniques.



**FIGURE 9.19** Schematics for Example 9.6.

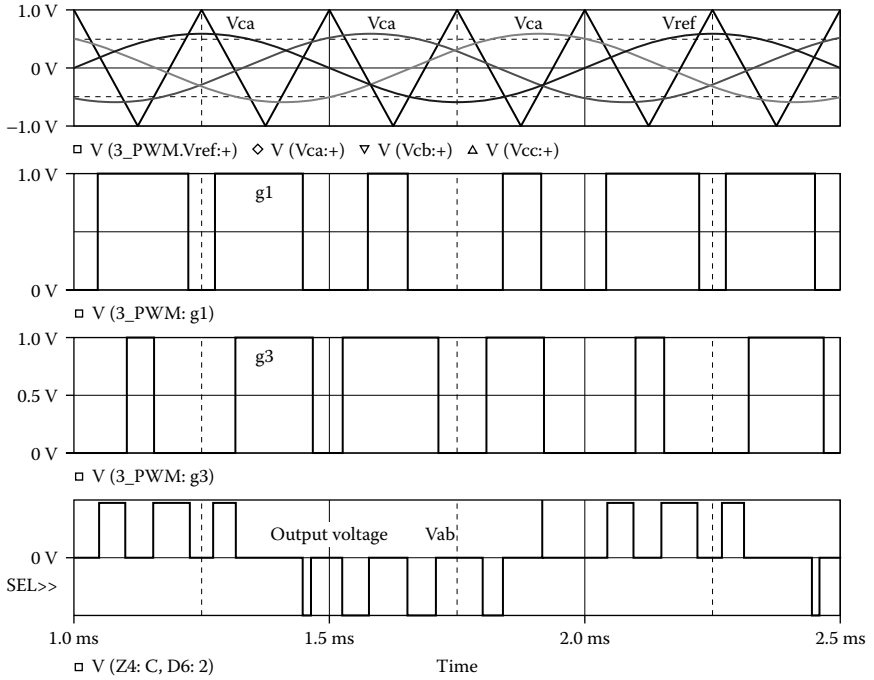


FIGURE 9.20 Plots for Example 9.6.

**EXAMPLE 9.7 FINDING THE PERFORMANCE OF A SINGLE-PHASE CURRENT-SOURCE INVERTER**

A single-phase current-source inverter is shown in Figure 9.21(a). The control voltages are shown in Figure 9.21(b). The DC input voltage is 100 V. The output frequency is  $f_o = 1$  kHz. The chopping frequency is  $f_s = 2$  kHz, and its duty cycle is  $k = 0.6$ . The load resistance is  $R = 10 \Omega$ , and the load inductance is  $L = 6.5$  mH. Use PSpice to (a) plot the instantaneous output current  $i_o$ , the instantaneous source current  $i_s$ , and the instantaneous current  $i_l$  through inductor  $L_c$  and (b) calculate the Fourier coefficients of the output current  $i_o$ . The model parameters of the BJTs are IS = 2.33E27, BF = 13, CJE = 1PF, CJC = 607.3PF, and TF = 26.5NS. The model parameters of the MOSFETs are VTO = 2.83, KP = 31.2U, L = 1U, W = 3.0M, CGDO = 1.359N, and CGSO = 2.032N.

**SOLUTION**

$f_o = 1$  kHz,  $f_s = 2$  kHz, and  $k = 0.6$ . BJTs are used as switching devices in the PSpice schematic shown in Figure 9.22. The PWM generator varies the duty cycle of the DC-DC converter, which can change its output voltage in order to vary the current-source inductor current  $I_m$ .



```

Vg3 11 12 PULSE (0 40V 500US 1NS 1NS 0.5MS 1MS)
Rb4 14 13 50
Rg4 14 15 10MEG
Vg4 14 15 PULSE (0 40V 750US 1NS 1NS 0.5MS 1MS)
CIRCUIT ■ VY 1 23 DC 0V ; Voltage source to measure supply
                    current
VX 5 19 DC 0V ; Measures load current
R 19 20 10
L 20 6 6.5MH ; L is included
Le 2 3 10MH IC=1A
Ce 3 0 100UF
Lm 3 4 20MH IC=3A
D1 9 5 DMOD ; Diode
D2 18 0 DMOD ; Diode
D3 12 6 DMOD ; Diode
D4 15 0 DMOD ; Diode
DM 0 2 DMOD ; Diode
.MODELDMODD (IS=2.22E-15 BV=1200V IBV=13E-3 CJO=1PF
TT=0) ; Diode model
M1 23 21 2 2 IRF150 ; MOSFET switch
MODEL IRF150 NMOS(VTO=2.83 KP=31.2U L=1U W=3.0M
+ CGDO=1.359N CGSO=2.032N) ; MOSFET parameters
Q1 4 7 9 9 2N6546 ; BJT switch
Q2 6 16 18 18 2N6546 ; BJT switch
Q3 4 10 12 12 2N6546 ; BJT switch
Q4 5 13 15 15 2N6546 ; BJT switch
.MODEL 2N6546 NPN(IS=2.33E-
27 BF=13 CJE=1PF CJC=607.3PF TF=26.5NS)
ANALYSIS ■■■ .TRAN 10US 5MS 3MS UIC ; Transient analysis
.PROBE ; Graphics post-processor
.OPTIONS ABSTOL = 1.00U RELTOL = 0.02 VNTOL = 0.1
ITL5 = 50000
.FOUR 1KHZ I(VX) ; Fourier analysis
.END

```

Note the following:

- (a) The PSpice plots of the instantaneous output current  $I(VX)$ , the current source  $I(Lm)$ , and the inductor current  $I(Le)$  are shown in [Figure 9.23](#). The output voltage is a square wave, as expected. It should be noted that the currents have not reached steady state.
- (b) The Fourier coefficients of the output current are as follows:

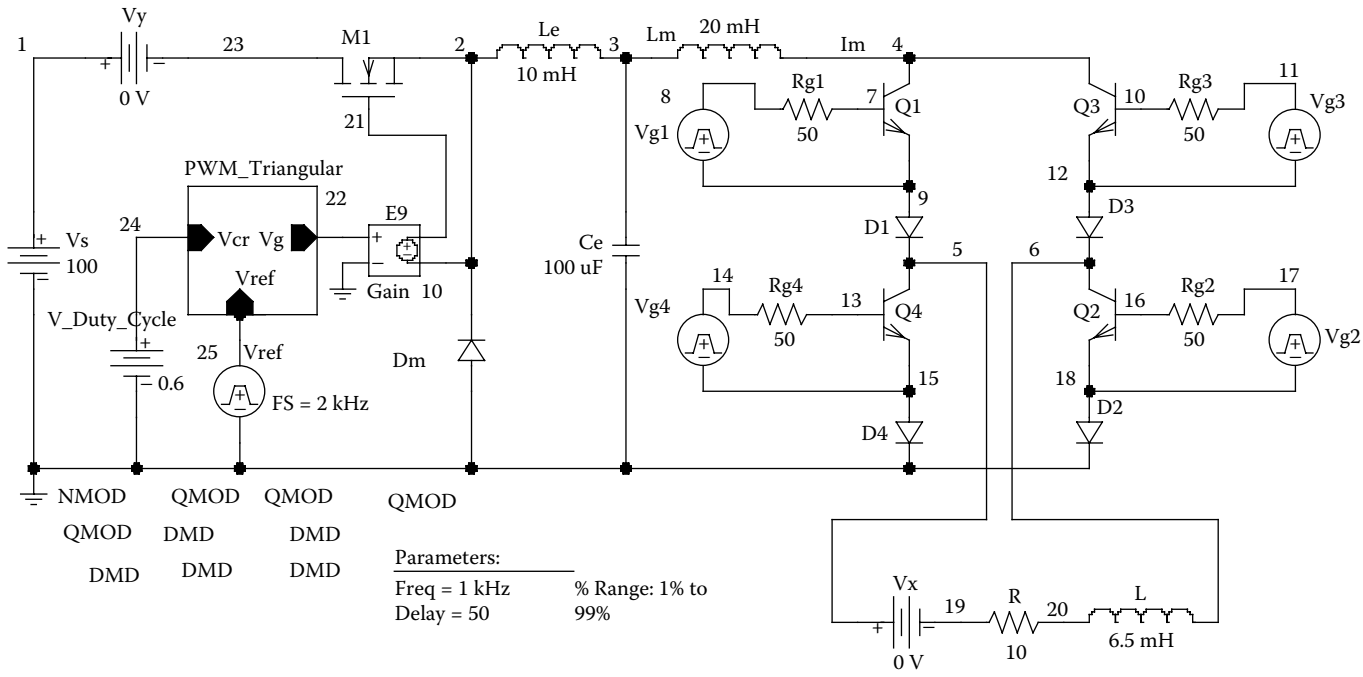


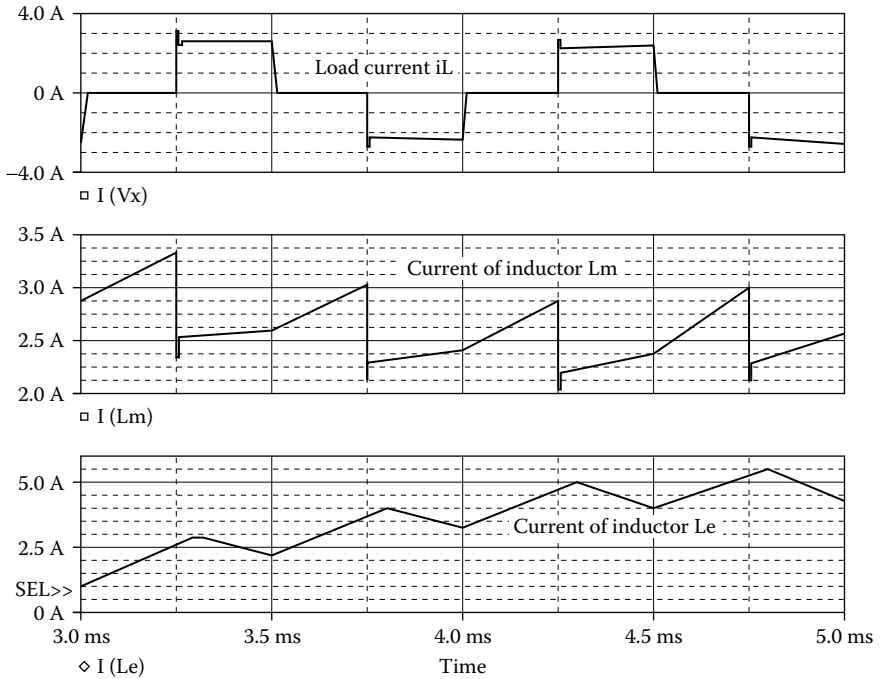
FIGURE 9.22 Schematics for Example 9.7.

**FOURIER COMPONENTS OF TRANSIENT RESPONSE I(VX)**

DC COMPONENT = 9.959469E-02

Harmonic No	Frequency (Hz)	Fourier Component	Normalized Component	Phase (Deg)	Normalized Phase (Deg)
1	1.000E+03	3.009E+00	1.000E+00	-4.814E+01	0.000E+00
2	2.000E+03	1.437E-01	4.775E-02	-1.759E+02	-1.278E+02
3	3.000E+03	9.189E-01	3.054E-01	3.520E+01	8.334E+01
4	4.000E+03	2.512E-02	8.347E-03	-1.064E+02	-5.831E+01
5	5.000E+03	6.507E-01	2.162E-01	-5.957E+01	-1.143E+01
6	6.000E+03	5.224E-02	1.736E-02	-1.633E+02	-1.152E+02
7	7.000E+03	3.570E-01	1.186E-01	2.344E+01	7.158E+01
8	8.000E+03	2.363E-02	7.853E-03	-1.062E+02	-5.803E+01
9	9.000E+03	3.878E-01	1.289E-01	-7.128E+01	-2.314E+01

TOTAL HARMONIC DISTORTION = 4.164380E+01 PERCENT



**FIGURE 9.23** Plots for Example 9.7.

*Note:* During the switching of the output current, the load voltage will exhibit high transients with an inductive load because of the rapid change of the current. The series diodes  $D_1$  to  $D_4$  are used to protect the transistors from these transients.

## 9.4 LABORATORY EXPERIMENTS

It is possible to develop many experiments to demonstrate the operation and characteristics of inverters. The following experiments are suggested:

- Single-phase half-bridge inverter
- Single-phase full-bridge inverter
- Single-phase full-bridge inverter with PWM control
- Single-phase full-bridge inverter with SPWM control
- Three-phase bridge inverter
- Single-phase current-source inverter
- Three-phase current-source inverter.

### 9.4.1 EXPERIMENT PW.1

#### Single-Phase Half-Bridge Inverter

- |                               |  |
|-------------------------------|--|
| <b>Objective</b>              | To study the operation and characteristics of a single-phase half-bridge (transistor) inverter under various load conditions.  |
| <b>Applications</b>           | The single-phase half-bridge inverter is used to control power flow in AC and DC power supplies, input stages of other converters, etc.  |
| <b>Textbook</b>               | See <a href="#">Reference 1</a> , Section 6.2.   |
| <b>Apparatus</b>              | <ol style="list-style-type: none"> <li>1. Two BJTs or MOSFETs with ratings of at least 50 A and 400 V, mounted on heat sinks</li> <li>2. Two fast-recovery diodes with ratings of at least 50 A and 400 V, mounted on heat sinks</li> <li>3. A firing pulse generator with isolating signals for gating transistors</li> <li>4. An <math>RL</math> load</li> <li>5. One dual-beam oscilloscope with floating or isolating probes</li> <li>6. AC and DC voltmeters and ammeters and one noninductive shunt</li> </ol>   |
| <b>Warning</b>                | Before making any circuit connection, switch the DC power off. Do not switch on the power unless the circuit is checked and approved by your laboratory instructor. Do not touch the transistor or diode heat sinks, which are connected to live terminals.  |
| <b>Experimental procedure</b> | <ol style="list-style-type: none"> <li>1. Set up the circuit as shown in <a href="#">Figure 9.24</a>. Use the load resistance <math>R</math> only.</li> <li>2. Connect the measuring instruments as required.</li> <li>3. Connect the firing pulses to the appropriate transistors.</li> <li>4. Set one pulse per half cycle with a duty cycle of <math>k = 0.5</math>.</li> <li>5. Observe and record the waveforms of the load voltage <math>v_o</math> and the load current <math>i_o</math>.</li> <li>6. Measure the rms load voltage <math>V_{o(\text{rms})}</math>, the rms load current <math>I_{o(\text{rms})}</math>, the average input current <math>I_{s(\text{DC})}</math>, the DC input voltage <math>V_{s(\text{DC})}</math>, and the total harmonic distortion <math>THD</math> of the output voltage and current.</li> <li>7. Measure the conduction angles of transistor <math>Q_1</math> and diode <math>D_1</math>.</li> <li>8. Repeat steps 2 to 7 with both load resistance <math>R</math> and load inductance <math>L</math>.</li> </ol> |
| <b>Report</b>                 | <ol style="list-style-type: none"> <li>1. Present all recorded waveforms and discuss all significant points.</li> <li>2. Compare the waveforms generated by SPICE with the experimental results, and comment.</li> <li>3. Compare the experimental results with the predicted results.</li> <li>4. Discuss the advantages and disadvantages of this type of inverter.</li> <li>5. Discuss the effects of the diodes on the performance of the inverter.</li> </ol>   |

### 9.4.2 EXPERIMENT PW.2

#### Single-Phase Full-Bridge Inverter

<b>Objective</b>	To study the operation and characteristics of a single-phase full-bridge (transistor) inverter under various load conditions.
<b>Applications</b>	See <a href="#">Experiment PW.1</a> .
<b>Textbook</b>	See <a href="#">Reference 1</a> , Section 6.4.
<b>Apparatus</b>	Similar to <a href="#">Experiment PW.1</a> , except that four BJTs or MOSFETs with four fast-recovery diodes are required as shown in <a href="#">Figure 9.24</a> .
<b>Warning</b>	See <a href="#">Experiment PW.1</a> .
<b>Experimental procedure</b>	See <a href="#">Experiment PW.1</a> .
<b>Report</b>	See <a href="#">Experiment PW.1</a> .

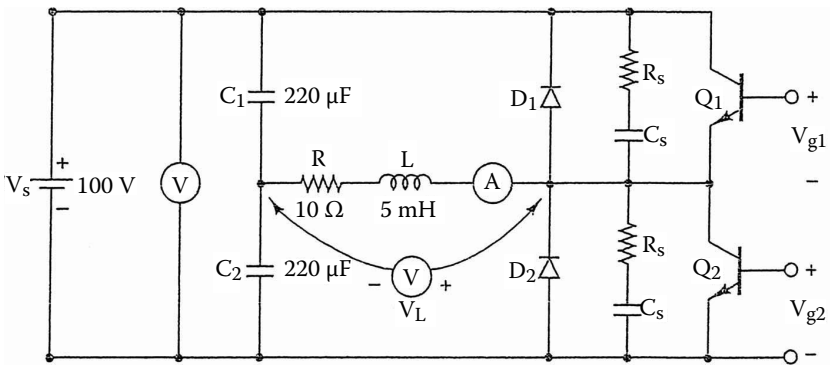


FIGURE 9.24 Single-phase half-bridge inverter.

### 9.4.3 EXPERIMENT PW.3

#### Single-Phase Full-Bridge Inverter with PWM Control

<b>Objective</b>	To study the effects of PWM control on the THD of the output voltage in a single-phase full-bridge (transistor) inverter with a resistive load.
<b>Applications</b>	Similar to <a href="#">Experiment PW.1</a> .
<b>Textbook</b>	See <a href="#">Reference 1</a> , Section 6.4 and Section 6.6.
<b>Apparatus</b>	Similar to <a href="#">Experiment PW.1</a> , except that four BJTs or MOSFETs and four fast-recovery diodes are required.
<b>Warning</b>	See <a href="#">Experiment PW.1</a> .
<b>Experimental procedure</b>	<ol style="list-style-type: none"> <li>1. Set up the circuit as shown in <a href="#">Figure 9.25</a>. Use the load resistance <math>R</math> only.</li> <li>2. Set one pulse per half cycle, <math>p = 1</math>, and the modulation index <math>M = 0.5</math>.</li> <li>3. Measure the rms load voltage <math>V_{o(rms)}</math> and the THD of the output voltage.</li> <li>4. Repeat step 3 for <math>p = 2, 3, 4</math>, and 5.</li> <li>5. Repeat steps 2 and 4 for <math>M = 0.1</math> to 1 with an increment of 0.1.</li> </ol>
<b>Report</b>	<ol style="list-style-type: none"> <li>1. Plot the rms output voltage and THD of the output voltage against the modulation <math>M</math> for various values of <math>p</math>.</li> </ol>

2. Use SPICE or MathCAD to predict the rms output voltage and THD.
3. Compare the experimental results with the predicted results, and comment.

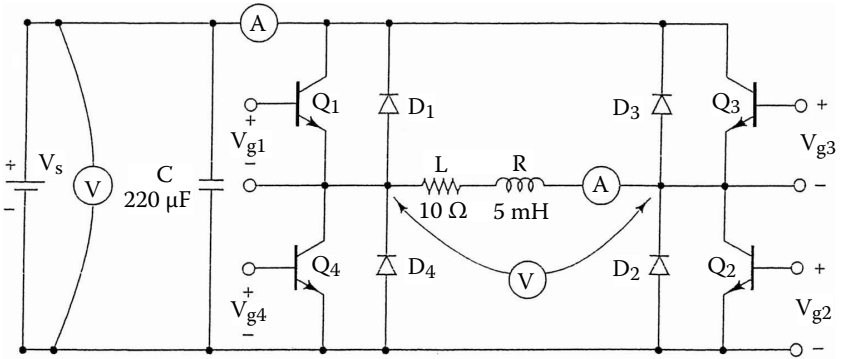


FIGURE 9.25 Single-phase full-bridge inverter.

#### 9.4.4 EXPERIMENT PW.4

##### Single-Phase Full-Bridge Inverter with SPWM Control

<b>Objective</b>	To study the effects of SPWM control on the THD of the output voltage for a single-phase full-bridge (transistor) inverter under a resistive load.
<b>Applications</b>	See <a href="#">Experiment PW.1</a> .
<b>Textbook</b>	See <a href="#">Reference 1</a> , Section 6.4 and Section 6.6.
<b>Apparatus</b>	See <a href="#">Experiment PW.2</a> .
<b>Warning</b>	See <a href="#">Experiment PW.1</a> .
<b>Experimental procedure</b>	See <a href="#">Experiment PW.3</a> .
<b>Report</b>	See <a href="#">Experiment PW.3</a> .

#### 9.4.5 EXPERIMENT PW.5

##### Three-Phase Bridge Inverter

<b>Objective</b>	To study the operation and characteristics of a three-phase bridge (transistor) inverter under various load conditions.
<b>Applications</b>	The three-phase bridge inverter is used to control power flow in AC power supplies, AC motor drives, etc.
<b>Textbook</b>	See <a href="#">Reference 1</a> , Section 6.5 and Section 6.6.
<b>Apparatus</b>	Similar to <a href="#">Experiment PW.1</a> , except that six BJTs or MOSFETs and six fast-recovery diodes are required.
<b>Warning</b>	See <a href="#">Experiment PW.1</a> .
<b>Experimental procedure</b>	<ol style="list-style-type: none"> <li>1. Set up the circuit as shown in <a href="#">Figure 9.26</a>. Use a wye-connected resistive load <math>R</math> only.</li> <li>2. Connect the measuring instruments as required.</li> <li>3. Connect the firing pulses to the appropriate transistors.</li> </ol>

4. Set one pulse per half cycle with a duty cycle of  $k = 0.5$ .
5. Observe and record the waveforms of the output phase voltage, the output line-line voltage, and the load phase current  $i_o$ .
6. Measure the rms load phase voltage  $V_{p(rms)}$ , the rms load phase current  $I_{p(rms)}$ , the average input current  $I_{s(DC)}$ , the average input voltage  $V_{s(DC)}$ , and the THD of the output phase voltage and phase current.
7. Measure the conduction angles of transistor  $Q_1$  and diode  $D_1$ .
8. Repeat steps 2 to 7 with both load resistance  $R$  and load inductance  $L$ .
9. Repeat steps 1 to 8 with a delta-connected load.

**Report**

See [Experiment PW.1](#).

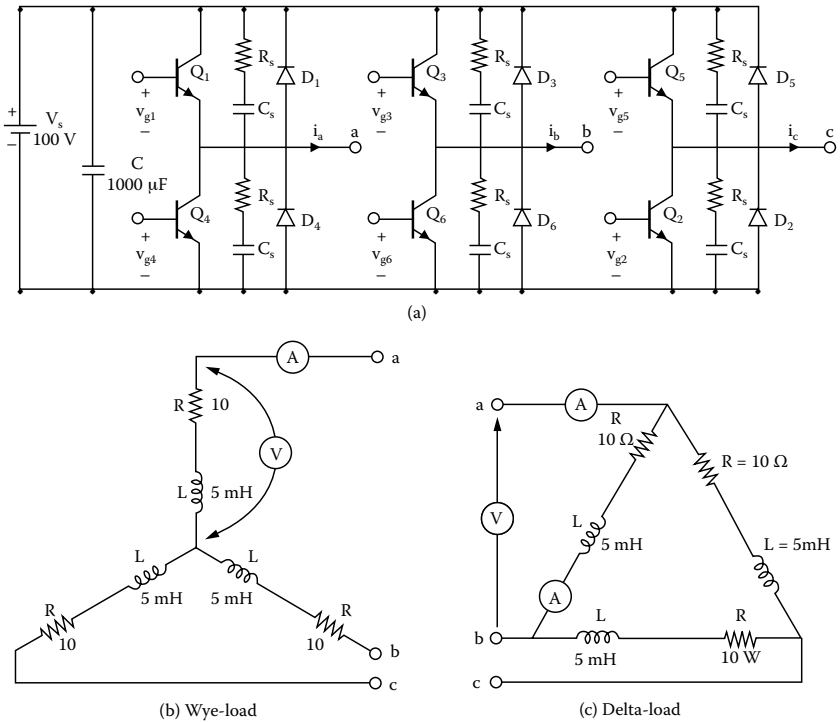


FIGURE 9.26 Three-phase bridge inverter.

**9.4.6 EXPERIMENT PW.6**

**Single-Phase Current-Source Inverter**

- Objective** To study the operation and characteristics of a single-phase current-source (transistor) inverter under various load conditions.
- Applications** The current-source inverter is used to control power flow in AC power supplies, etc.
- Textbook** See [Reference 1](#), Section 6.11.

**Apparatus**

Similar to Experiment PW.1, except that four BJTs or MOSFETs and four fast-recovery diodes are required.

**Warning**

See [Experiment PW.1](#).

**Experimental procedure**

1. Set up the circuit as shown in Figure 9.27. Use a resistive load  $R$  only.
2. Connect the measuring instruments as required.
3. Connect the firing pulses to the appropriate transistors.
4. Set the duty cycle of the chopper at  $k = 0.5$ . Set the inverter to one pulse per half cycle with a duty cycle of  $k = 0.5$ .
5. Observe and record the waveforms of the output voltage and the output current.
6. Measure the rms load voltage  $V_{o(rms)}$ , the rms load current  $I_{o(rms)}$ , the average input current  $I_{s(DC)}$ , the DC input voltage  $V_{s(DC)}$ , and the *THD* of the output current.
7. Measure the conduction angles of the transistor  $Q_1$ .
8. Repeat steps 2 to 7 with both load resistance  $R$  and load inductance  $L$ .

**Report**

See Experiment PW.1.

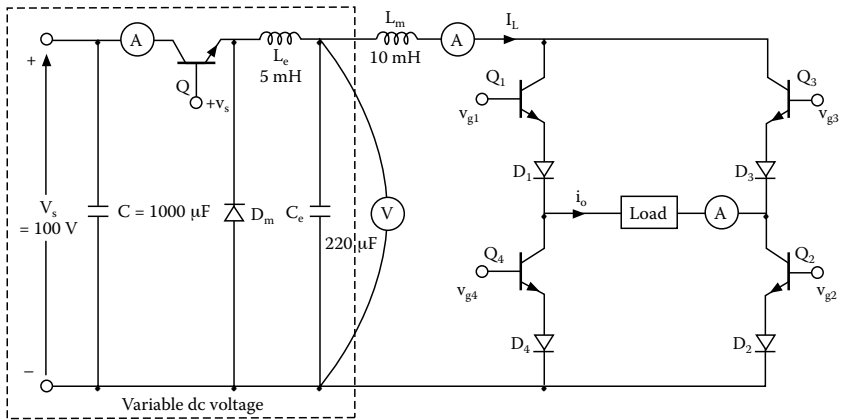


FIGURE 9.27 Single-phase current-source inverter.

### 9.4.7 EXPERIMENT PW.7

#### Three-Phase Current-Source Inverter

**Objective**

To study the operation and characteristics of a three-phase current-source (transistor) inverter under resistive load.

**Applications**

The three-phase current-source inverter is used to control power flow in AC power supplies, AC motor drives, etc.

**Textbook**

See [Reference 1](#), Section 6.11.

**Apparatus**

Similar to Experiment PW.1, except that six BJTs or MOSFETs and six fast-recovery diodes are required.

**Warning**

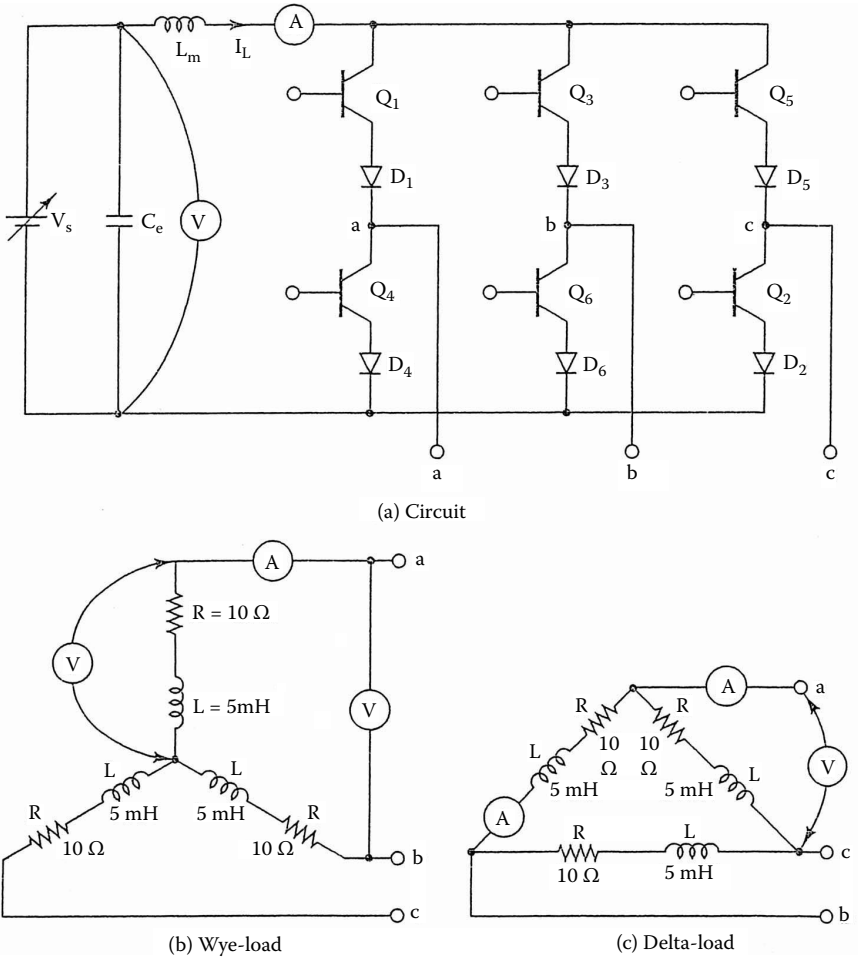
See Experiment PW.1.

**Experimental procedure**

1. Set up the circuit as shown in Figure 9.28. Use a wye-connected resistive load  $R$  only.
2. Connect the measuring instruments as required.
3. Connect the firing pulses to the appropriate transistors.
4. Set one pulse per half cycle with a duty cycle of  $k = 0.5$ .
5. Observe and record the waveforms of the output phase current  $i_o$ .
6. Measure the rms load phase current, average input current, and DC input voltage, and the  $THD$  of the output phase current.
7. Measure the conduction angles of the transistor  $Q_1$  and diode  $D_1$ .

**Report**

See [Experiment PW.1](#).



**FIGURE 9.28** Three-phase current-source inverter.

## SUMMARY

The statements for an AC thyristor are:

\*Subcircuit call for switched transistor model:

```
XT1      +N      -N      +NG      -NG      QM
         positive negative +control -control model
*
         voltage  voltage  name
```

\*Subcircuit call for PWM control:

```
XPWM  VR      VC      +NG      -NG      PWM
*      ref carrier +control -control model
*      input input  voltage  voltage name
```

\*Subcircuit call for sinusoidal PWM control:

```
XSPWM VR      VS      +NG      -NG      VC      SPWM
*      ref sine-wave +control -control  rectified  model
*      input input  voltage  voltage  carrier sine wave name
```

## Suggested Reading

1. M.H. Rashid, *Power Electronics: Circuit, Devices and Applications*, 3rd ed., Englewood Cliff, NJ: Prentice-Hall, 2003, chap. 6.
2. M.H. Rashid, *Introduction to PSpice Using OrCAD for Circuits and Electronics*, 3rd ed., Englewood Cliff, NJ: Prentice-Hall, 2003, chap. 7.
3. M.H. Rashid, *SPICE For Power Electronics and Electric Power*, Englewood Cliff, NJ: Prentice-Hall, 1993.
4. N. Mohan, T.M. Undeland, and W.P. Robbins, *Power Electronics: Converters, Applications and Design*, New York: John Wiley & Sons, 2003.
5. V. Voperian, R. Tymerski, and F.C.Y. Lee, Equivalent Circuit models for resonant and PWM switches, *IEEE Transactions on Power Electronics*, Vol. 4, No. 2, 1990, pp. 205-214.

## DESIGN PROBLEMS

### 9.1

It is required to design the single-phase half-bridge inverter of [Figure 9.24](#) with the following specifications:

DC supply voltage,  $V_s = 100$  V

Load resistance,  $R = 5 \Omega$ .

Load inductance,  $L = 5$  mH

Output frequency,  $f_o = 1$  kHz

- (a) Determine the ratings of all components and devices under worst-case conditions.
- (b) Use SPICE to verify your design.
- (c) Provide a cost estimate of the circuit.

## 9.2

It is required to design the single-phase full-bridge inverter of [Figure 9.25](#) with the following specifications:

DC supply voltage,  $V_s = 100$  V

Load resistance,  $R = 5 \Omega$

Load inductance,  $L = 5$  mH

Output frequency,  $f_o = 1$  kHz

- (a) Determine the ratings of all components and devices under worst-case conditions.
- (b) Use SPICE to verify your design.
- (c) Provide a cost estimate of the circuit.

## 9.3

- (a) Design an output  $C$  filter for the single-phase full-bridge inverter of Problem 9.2. The harmonic content of the load current should be less than 5% of the value without the filter.
- (b) Use SPICE to verify your design in part (a).

## 9.4

It is required to design the three-phase bridge inverter of [Figure 9.26](#) with the following specifications:

DC supply voltage,  $V_s = 100$

Load resistance per phase,  $R = 5 \Omega$

Load inductance per phase,  $L = 5$  mH

Output frequency,  $f_o = 1$  kHz

- (a) Determine the ratings of all components and devices under worst-case conditions.
- (b) Use SPICE to verify your design.
- (c) Provide a cost estimate of the circuit.

## 9.5

It is required to design the single-phase current-source inverter of [Figure 9.27](#) with the following specifications:

DC supply voltage,  $V_s = 100 \text{ v}$

Average value DC current source,  $I_s = 10 \text{ A}$

Load resistance,  $R = 5 \Omega$

Load inductance,  $L = 5 \text{ mH}$

Output frequency,  $f_o = 400 \text{ Hz}$

- (a) Determine the ratings of all components and devices under worst-case conditions.
- (b) Use SPICE to verify your design.
- (c) Provide a cost estimate of the circuit.

## 9.6

- (a) Design an output  $C$  filter for the single-phase current-source inverter of Problem 9.5. The harmonic content of the load current should be less than 5% of the value without the filter.
- (b) Use SPICE to verify your design in part (a).

## 9.7

It is required to design the three-phase current-source inverter of [Figure 9.28](#) with the following specifications:

DC supply voltage,  $V_s = 100 \text{ V}$

Average value DC current source,  $I_s = 10 \text{ A}$

Load resistance per phase,  $R = 5 \Omega$

Load inductance per phase,  $L = 5 \text{ mH}$

Output frequency,  $f_o = 400 \text{ Hz}$

- (a) Determine the ratings of all components and devices under worst-case conditions.
- (b) Use SPICE to verify your design.
- (c) Provide a cost estimate of the circuit.

## 9.8

- (a) Design an output  $C$  filter for the three-phase current-source inverter of Problem 9.7. The harmonic content of the load current should be less than 5% of the value without the filter.
- (b) Use SPICE to verify your design in part (a).

## 9.9

Use PSpice to find the  $THD$  of the output voltage for a single-phase PWM inverter. Complete the following table for a modulation index of  $M = 0.05$  to  $0.95$  and

different pulses per half cycle,  $p = 1$  to 8. Assume a resistive load of  $R = 10 \Omega$ , a DC input voltage  $V_s = 100 \text{ V}$ , and an output frequency of  $f_o = 60 \text{ Hz}$ . Use any suitable switching devices.

	P/M	0.05	0.1	0.2	0.3	0.4	0.5	0.6	0.7	0.8	0.9	0.95
THD% of output voltage	1											
	2											
	4											
	5											
	6											
	7											
	8											

### 9.10

Use PSpice to find the *THD* of the output voltage for a single-phase SPWM inverter. Complete the table of Problem 9.9 with a modulation index of  $M = 0.05$  to 0.95 and different pulses per half cycle,  $p = 1$  to 8. Assume a resistive load of  $R = 10 \Omega$ , a DC input voltage  $V_s = 100 \text{ V}$ , and an output frequency of  $f_o = 60 \text{ Hz}$ . Use any suitable switching devices.

### 9.11

Use PSpice to find the *THD* of the wye-connected output phase voltage for a three-phase PWM inverter. Complete the table of Problem 9.9 with a modulation index of  $M = 0.05$  to 0.95 and different pulses per half cycle,  $p = 1$  to 8. Assume a resistive load of  $R = 10 \Omega$ , a DC input voltage  $V_s = 100 \text{ V}$ , and output frequency of  $f_o = 60 \text{ Hz}$ . Use any suitable switching devices.

### 9.12

Use PSpice to find the *THD* of the wye-connected output phase voltage for a three-phase sinusoidal PWM inverter. Complete the table of Problem 9.9 with a modulation index of  $M = 0.05$  to 0.95 and different pulses per half cycle,  $p = 1$  to 8. Assume a resistive load of  $R = 10 \Omega$ , a DC input voltage  $V_s = 100 \text{ V}$ , and an output frequency of  $f_o = 60 \text{ Hz}$ . Use any suitable switching devices.

### 9.13

Use PSpice to find the *THD* of the output current for a single-phase current-source inverter for different delay angles from  $0$  to  $180^\circ$  with an increment of  $20^\circ$ . Assume a resistive load of  $R = 10 \Omega$ , a DC input voltage  $V_s = 100 \text{ V}$ , and an output frequency of  $f_o = 60 \text{ Hz}$ . Use any suitable switching devices.

---

# 10 Resonant-Pulse Inverters

The learning objectives of this chapter are:

- Modeling BJTs and IGBTs in SPICE, and specifying their mode parameters
- Modeling current- and voltage-controlled switches
- Performing transient analysis of voltage-source and current-source resonant-pulse inverters
- Evaluating the performance of voltage-source and current-source resonant-pulse inverters
- Performing worst-case analysis of resonant-pulse inverters for parametric variations of model parameters and tolerances

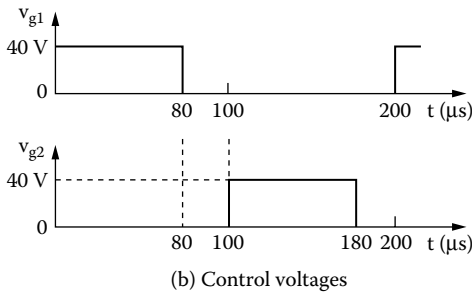
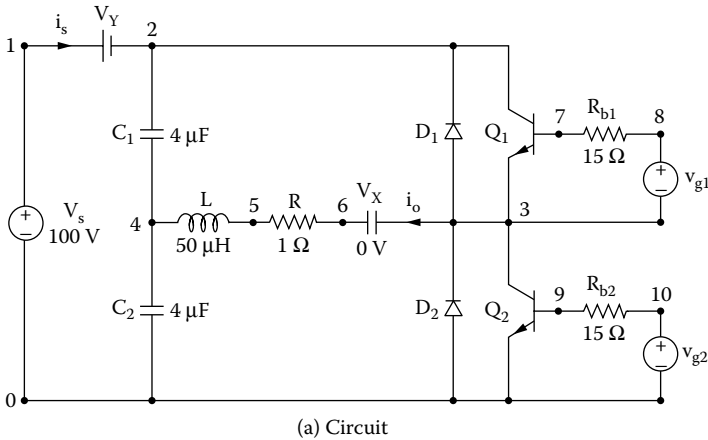
## 10.1 INTRODUCTION

The input to a resonant inverter is a DC voltage or current source, and the output is a voltage or current resonant pulse. Power semiconductor devices perform the switching action, and the desired output is obtained by varying their turn-on and turn-off times. The commonly used devices are BJTs, MOSFETs, IGBTs, MCTs, GTOs, and SCRs. We shall use PSpice switches, IGBTs, and BJTs to simulate the characteristics of the following inverters:

Resonant-pulse inverters  
Zero-current switching converters  
Zero-voltage switching converter

## 10.2 RESONANT-PULSE INVERTERS

The switches of resonant inverters are turned on to initiate resonant oscillations and are maintained in an on-state condition to complete the oscillations. The output waveform depends mainly on the circuit parameters and the input source. The on time and switching frequency of power devices must match the resonant frequency of the circuit.



**FIGURE 10.1** Half-bridge resonant inverter. (a) Circuit, (b) control voltages.

### EXAMPLE 10.1 FINDING THE PERFORMANCE OF A HALF-BRIDGE RESONANT-PULSE INVERTER WITH BJT SWITCHES

A half-bridge resonant inverter is shown in Figure 10.1(a). The control voltages are shown in Figure 10.1(b). The DC input voltage is 100 V. The output frequency is  $f_o = 5$  kHz. The load resistance is  $R = 1 \Omega$ , and the load inductance is  $L = 50 \mu\text{H}$ . Use PSpice to (a) plot the instantaneous output current  $i_o$  and the instantaneous input supply current  $i_s$  and (b) calculate the Fourier coefficients of the output current  $i_o$ . The BJT parameters are  $IS = 2.33\text{E}-27$ ,  $BF = 13$ ,  $CJE = 1\text{PF}$ ,  $CJC = 1607.3\text{PF}$ , and  $TF = 26.5\text{NS}$ .

### SOLUTION

The values of gate voltage  $V_g$  and base resistance  $R_b$  must be such that the transistors are driven into saturation at the expected load current. The PSpice schematic with BJTs is shown in Figure 10.2. Varying the duty cycle can change the output voltage. The switching frequency {FREQ} and the duty cycle {DUTY\_CYCLE} are defined as variables. The model parameters for the BJTs and the freewheeling diodes are as follows:

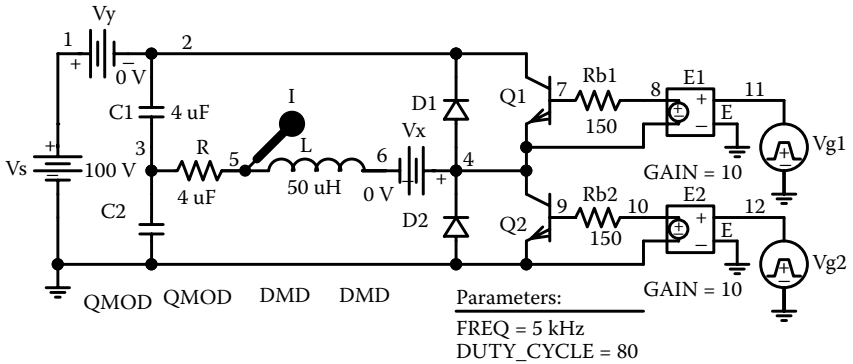


FIGURE 10.2 PSpice schematic for Example 10.1.

```
.MODEL QMOD NPN(IS=6.83E-14 BF=13 CJE=1pF CJC=607.3PF
TF=26.5NS) for IGBTs
```

```
.MODEL DMD D(IS=2.22E-15 BV=1200V CJO=0PF TT=0US)) for
BJTs
```

The listing of the circuit file is as follows:

### Example 10.1 Half-bridge resonant inverter

```
SOURCE ■ VS 1 0 DC 100V
.PARAM DUTY_CYCLE=80 FREQ=5kHz
Vg1 8 3 PULSE (0 40 0 1ns 1ns {{Duty_Cycle}}/(200*
{Freq})-2ns) {1/{Freq}}
Vg2 10 0 PULSE 0 40 {1/(2*{Freq})} 1ns 1ns
{{Duty_Cycle}}/(200*{Freq})-2ns) {1/{Freq}}
CIRCUIT ■ Rb1 8 7 15
Rb2 10 9 15
VY 1 2 DC 0V ; Voltage source to measure supply current
VX 3 6 DC 0V ; Measures load current
R 6 5 1
L 5 4 50UH
C1 2 4 4UF
C2 4 0 4UF
D1 3 2 DMOD ; Diode
D2 0 3 DMOD ; Diode
.MODEL DMOD D(IS=2. 2E-15 BV=1200V CJO=0 TT=0) ; Diode
model parameters
```

```

Q1  2 7 3 3 2N6546      ; BJT switch
Q2  3 9 0 0 2N6546      ; BJT switch
.MODEL 2N6546 NPN (IS=2.33E-27 BF=13 CJE=1PF
CJC=607.3PF TF=26.5NS)
ANALYSIS ■■■ .TRAN 1US 400US      ; Transient analysis
.PROBE ; Graphics post-processor
.OPTIONS ABSTOL = 1.00N RELTOL = 0.01 VNTOL= 0.1
ITL5=50000
.FOUR 5KHZ I(VX)      ; Fourier analysis
.END

```

Note the following:

- The PSpice plots of the instantaneous output current  $I(VX)$  and the current source  $I(VY)$  for  $f_o = 5$  kHz are shown in [Figure 10.3](#). For  $f_o = 4$  kHz, the switching period is changed to 250  $\mu$ sec, and the plots are shown in [Figure 10.4](#). As expected, the output voltage can be varied by changing the switching frequency.
- The Fourier coefficients of the output current are as follows:

---

### FOURIER COMPONENTS OF TRANSIENT RESPONSE I(VX)

DC COMPONENT = 2.185143E-01

Harmonic No	Frequency (Hz)	Fourier Component	Normalized Component	Phase (Deg)	Normalized Phase (Deg)
1	5.000E+03	2.566E+01	1.000E+00	6.723E+01	0.000E+00
2	1.000E+04	9.637E-01	3.756E-02	1.020E+01	-5.703E+01
3	1.500E+04	6.027E+00	2.349E-01	-7.231E+01	-1.395E+02
4	2.000E+04	2.216E-01	8.636E-03	-3.107E-01	-6.754E+01
5	2.500E+04	1.781E+00	6.943E-02	-7.669E+01	-1.439E+02
6	3.000E+04	1.362E-01	5.308E-03	-5.628E+00	-7.286E+01
7	3.500E+04	8.531E-01	3.325E-02	-7.579E+01	-1.430E+02
8	4.000E+04	1.193E-01	4.649E-03	1.046E+00	-6.619E+01
9	4.500E+04	5.075E-01	1.978E-02	-7.477E+01	-1.420E+02

TOTAL HARMONIC DISTORTION = 2.510610E+01 PERCENT

---

*Note:* With a lower frequency, there may not be enough time for the resonant oscillation to complete the cycle and the peak current is lower. The resonant current may also be discontinuous.

### EXAMPLE 10.2 FINDING THE PERFORMANCE OF A PARALLEL RESONANT INVERTER WITH VOLTAGE-CONTROLLED SWITCHES

A parallel resonant inverter is shown in [Figure 10.5\(a\)](#). The control voltages are shown in [Figure 10.5\(b\)](#). The DC input voltage is 100 V. The output frequency is

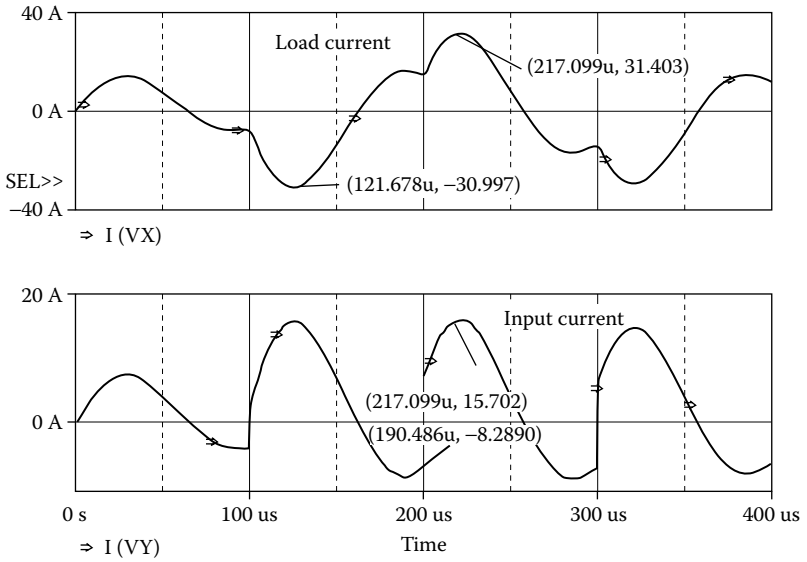


FIGURE 10.3 Plots at  $f_0 = 5$  kHz for Example 10.1.

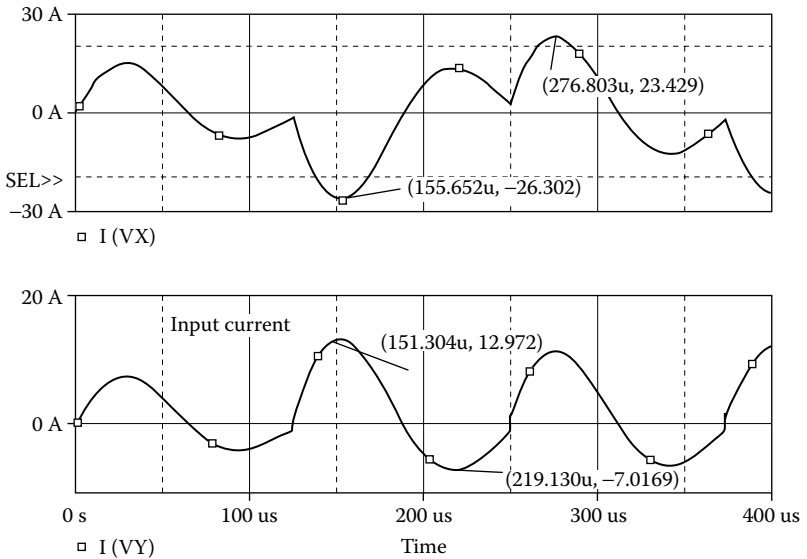


FIGURE 10.4 Plots at  $f_0 = 4$  kHz for Example 10.1.

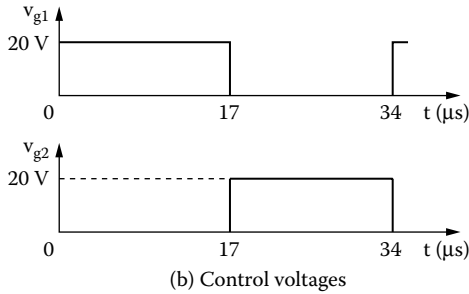
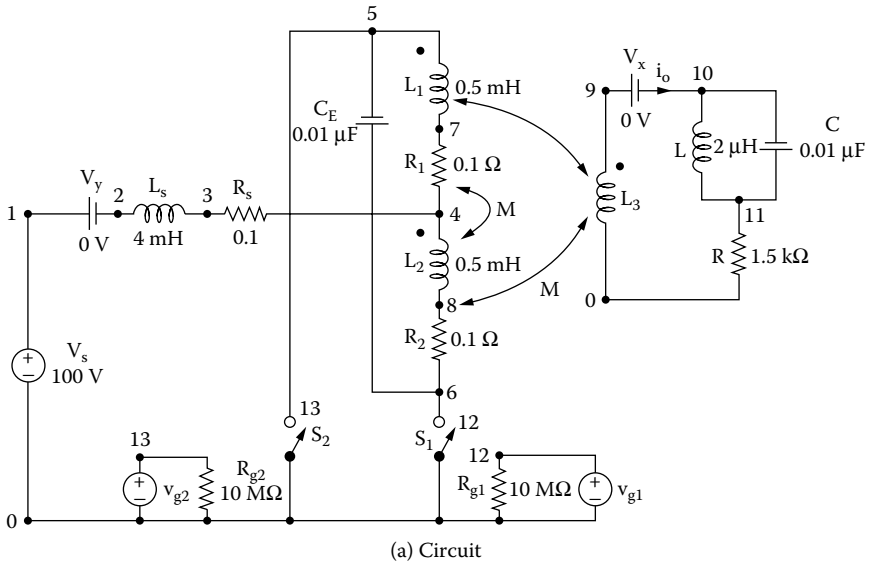


FIGURE 10.5 Parallel resonant inverter. (a) Circuit, (b) control voltages.

$f_o = 29.3$  kHz. Use PSpice to (a) plot the instantaneous output current  $i_o$  and the instantaneous input supply current  $i_s$  and (b) calculate the Fourier coefficients of the output current  $i_o$ . Use voltage-controlled switches to perform the switching action.

**SOLUTION**

The inductor  $L_s$  acts as a current source. It is generally necessary to adjust the on time of the switches to match the resonant frequency of the circuit. The PSpice schematic is shown in Figure 10.6. Note that the inductors should be connected with proper dot signs. The switching frequency can be varied by changing the parameter {Freq}. The model parameters for the switch are as follows:

```
.MODEL SMD VSWITCH (RON=1M ROFF=10E6 VON=1V VOFF=0V)
```

The listing of the circuit file is as follows:

**Example 10.2 Push-pull resonant inverter**

```

SOURCE ■ VS 1 0 DC 100V
           .PARAM Freq=29.4kHz
           Vg1 12 0 PULSE (0 10V 0 1ns 1ns {1/(2*{Freq})-2ns}
           {1/{Freq}})
           Rg1 12 0 10MEG
           Vg2 13 0 PULSE (0 10V {1/(2*{Freq})} 1ns 1ns {1/(2*
           {Freq})-2ns} {1/{Freq}})
           Rg2 13 0 10MEG
CIRCUIT ■■ VX 9 10 DC 0V ; Measures load current
            VY 1 2 DC 0V ; Voltage source to measure supply current
            RS 3 4 0.1
            LS 2 3 4MH
            CE 5 6 0.01UF
            L1 5 7 0.5MH
            R1 7 4 0.1
            L2 4 8 0.5MH
            R2 8 6 0.1
            L3 9 0 3.5MH
            K12 L1 L2 0.9999
            K14 L1 L4 0.9999
            K24 L2 L4 0.9999
            L 10 11 2UH
            C 10 11 0.01UF
            R 11 0 1.5K
            S1 6 0 12 0 SMOD ; Voltage-controlled switch
            S2 5 0 13 0 SMOD ; Voltage-controlled switch
            .MODEL SMOD VSWITCH (RON=0.01 ROFF=10E+6 VON=1V VOFF=0MV)
ANALYSIS ■■■ .TRAN 0.1US 120US ; Transient analysis
                .PROBE ; Graphics post-processor .OPTIONS
                ABSTOL = 1.00N RELTOL = 0.01 VNTOL = 0.1 ITL5=50000
                .FOUR 29.3KHZ I(VX) ; Fourier analysis
                .END

```

Note the following:

- The PSpice pzplots of the instantaneous output current  $I(VX)$  and the current source  $I(VY)$  are shown in [Figure 10.7](#).
- The Fourier coefficients of the output current are as follows:

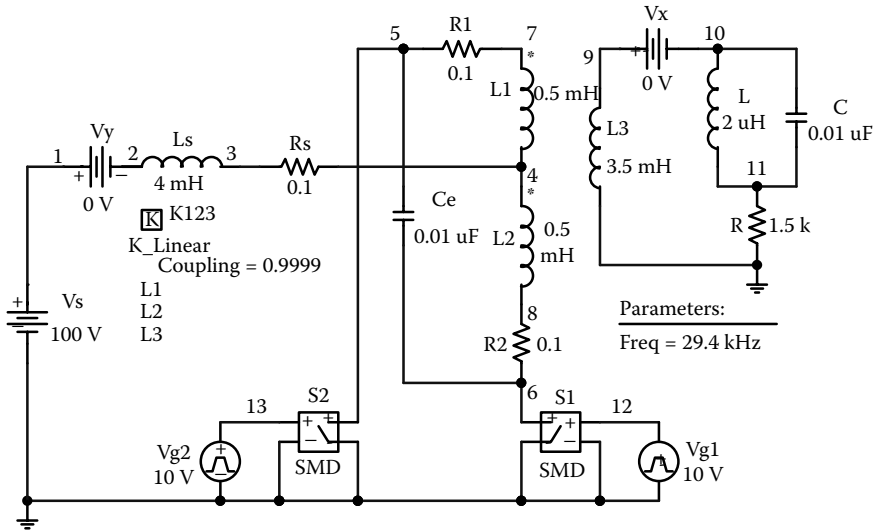


FIGURE 10.6 PSpice schematic for Example 10.2.

**FOURIER COMPONENTS OF TRANSIENT RESPONSE I(VX)**

DC COMPONENT = 9.019181E-05

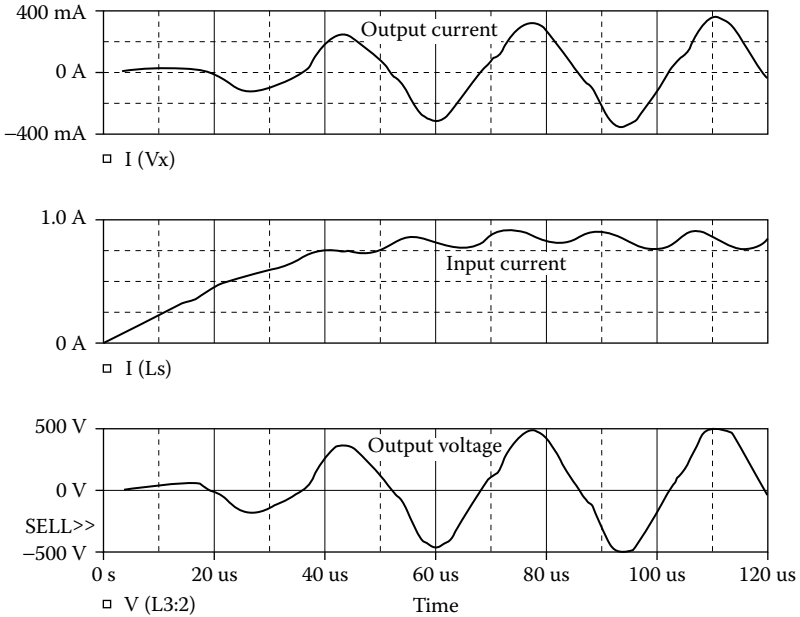
Harmonic No	Frequency (Hz)	Fourier Component	Normalized Component	Phase (Deg)	Normalized Phase (Deg)
1	2.930E+04	7.433E-02	1.000E+00	5.243E+01	0.000E+00
2	5.860E+04	2.302E-02	3.098E-01	1.345E+02	8.202E+01
3	8.790E+04	8.330E-03	1.121E-01	-4.895E+01	-1.014E+02
4	1.172E+05	4.527E-03	6.091E-02	1.299E+02	7.745E+01
5	1.465E+05	2.641E-03	3.553E-02	-4.305E+01	-9.548E+01
6	1.758E+05	1.825E-03	2.456E-02	1.424E+02	8.993E+01
7	2.051E+05	1.300E-03	1.749E-02	-2.515E+01	-7.759E+01
8	2.344E+05	1.083E-03	1.457E-02	1.535E+02	1.011E+02
9	2.637E+05	8.259E-04	1.111E-02	-1.467E+01	-6.710E+01

TOTAL HARMONIC DISTORTION = 3.387136E+01 PERCENT

*Note:* Because of the constant-current inductor  $L_s$ , the input current remains approximately constant within a certain amount of ripples. The output voltage  $V(L_3:L_1)$  will depend on the turns ratio  $N_s/N_p = (L_3/L_1)^{1/2}$ .

**10.3 ZERO-CURRENT SWITCHING CONVERTERS (ZCSC)**

A power device of a ZCSC is turned on and off at zero current by using an LC-resonant circuit. The device remains on and provides a path for completing the



**FIGURE 10.7** Plots for Example 10.2.

resonant oscillation. When the device is off, it has to withstand the peak voltage at zero current, thereby reducing the switching loss of the device. The output waveforms depend primarily on the circuit parameters and the input supply voltage. The switching period must be long enough to complete the resonant oscillation.

### EXAMPLE 10.3 FINDING THE PERFORMANCE OF AN M-TYPE ZERO-CURRENT SWITCHING RESONANT INVERTER

An M-type ZCSC is shown in Figure 10.8(a). The control voltage is shown in Figure 10.8(b). The DC input voltage is 15 V. The output frequency is  $f_o = 8.33$  kHz. Use PSpice to plot the instantaneous capacitor current  $i_c$ , the instantaneous capacitor voltage  $v_c$ , the diode voltage  $v_{Dm}$ , and instantaneous power loss across of the switch. Use voltage- and current-controlled switches to perform the switching action.

### SOLUTION

A current-controlled switch  $W_1$  is required to break the circuit when the resonant current falls to zero. When the supply is turned on, the capacitor will be charged to  $V_s$  and thus will have an initial voltage. The current-controlled switch  $W_1$  in Figure 10.8(a) can be replaced by a diode. The PSpice schematic with an IGBT switch is shown in Figure 10.9. The voltage-controlled voltage source  $E_1$  isolates the IGBT gate from the input gate signal  $V_g$ . The switching frequency and the duty

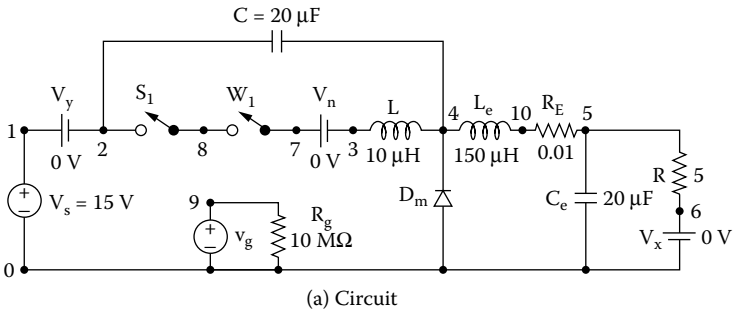


FIGURE 10.8 M-type ZCSC. (a) Circuit, (b) control voltage.

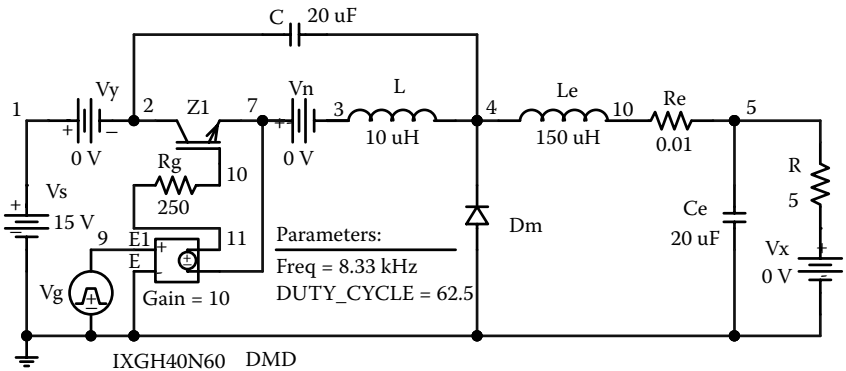


FIGURE 10.9 PSpice schematic for Example 10.3.

cycle can be varied by changing the parameters {Freq} and {Duty\_Cycle}. The model parameters for the IGBT switch are as follows:

```
.MODEL IXGH40N60 NIGBT (TAU=287.56E-9 KP=50.034
AREA=37.500E-6 AGD=18.750E-6
+ VT=4.1822 KF=.36047 CGS=31.942E-9 COXD=53.188E-9
VTD=2.6570)
```

The listing of the circuit file is as follows:

---

### Example 10.3 ZCSC

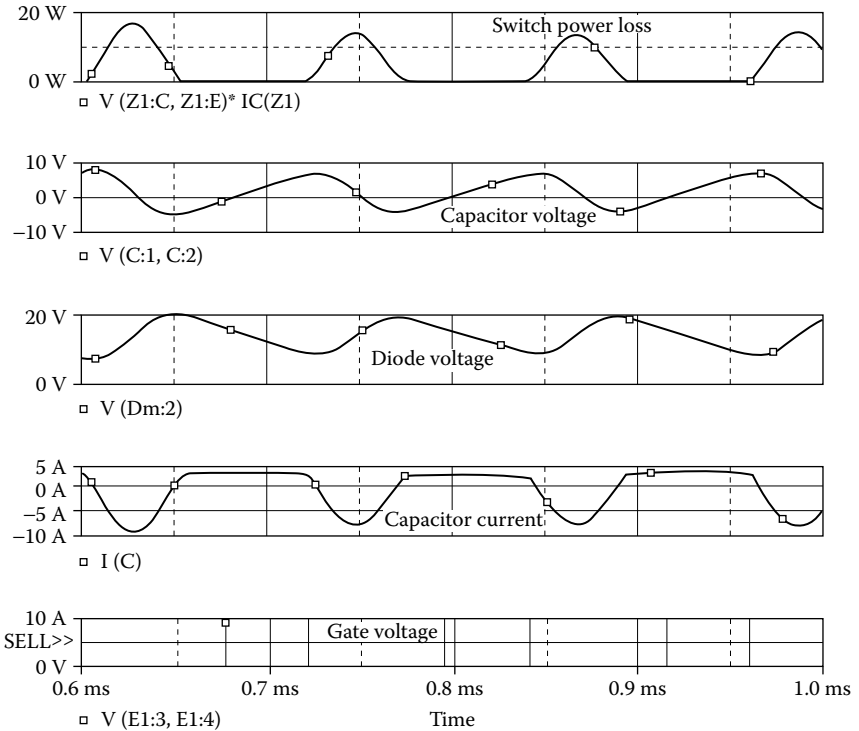
```

SOURCE   ■ VS  1 0 DC 15V
             .PARAM Freq=8.33kHz Duty_Cycle=62.5
             Rg  9 0 10MEG ; Control voltage
             Vg  9 0 PULSE (0 1 0 1ns 1ns {{Duty_Cycle}}/(100*
             {Freq})-2ns) {1/{Freq}}
CIRCUIT ■■ VY 1 2 DC 0V ; Voltage source to measure supply current
             VX 6 0 DC 0V ; Measures load current
             VN 7 3 DC 0V ; Measures the current-controlled switch
             R  5 6 55
             LE 4 10 150UH
             RE 10 5 0.01
             CE 5 0 20UF
             L  3 4 10UH
             C  2 4 20UF ; Initial condition
             DM 0 4 DMOD ; Diode
             .MODEL DMOD D (IS=2.2E-15BV=1200VCJO=0TT=0) ; Diode model
             parameters
             S1 2 8 9 0 SMOD ; Voltage-controlled switch
             .MODEL SMOD VSWITCH (RON=0.001ROFF=10E+6VON=10VVOFF=5V)
             W1 8 7 VN IMOD ; Current-controlled switch
             .MODEL IMOD ISWITCH (RON=1E+6 ROFF=0.01 ION=0
             IOFF=1UA) ; Model parameters
ANALYSIS ■■■ .TRAN 0.1US 400US ; Transient analysis
             .PROBE ; Graphics post-processor
             .OPTIONS ABSTOL = 1.00NRELTOL = 0.1VNTOL = 0.1ITL5=50000
             .END

```

---

The PSpice plots of the gate voltage V(9), the instantaneous capacitor voltage V(2,4), the capacitor current I(C), the diode voltage V(4), and the instantaneous power of the IGBT switch are shown in [Figure 10.10](#), where its peak instantaneous power is 13.06 W.



**FIGURE 10.10** Plots for Example 10.3.

#### EXAMPLE 10.4 FINDING THE PERFORMANCE OF AN L-TYPE ZERO-CURRENT SWITCHING RESONANT INVERTER

Repeat Example 10.3 for the L-type converter shown in [Figure 10.11\(a\)](#). The control voltage is shown in [Figure 10.11\(b\)](#).

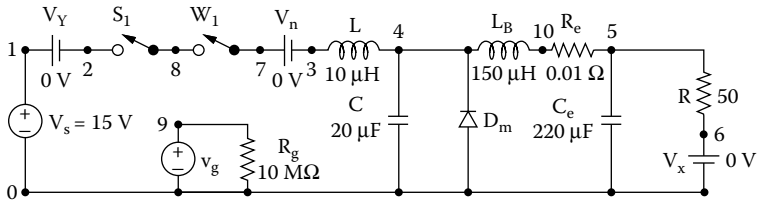
#### SOLUTION

The PSpice schematic is shown in [Figure 10.12](#), which is similar to that of [Figure 10.9](#).

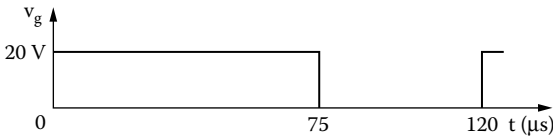
The circuit file is similar to that of Example 10.3, except that the capacitor  $C$  is connected across the diode  $D_m$ . The statement for  $C$  is changed to

```
C 4 0 20UF ; No initial condition
```

The PSpice plots of the instantaneous capacitor voltage  $V(2,4)$ , the inductor current  $I(L)$ , and the diode voltage  $V(4)$ , and the instantaneous power of the IGBT switch are shown in [Figure 10.13](#). The instantaneous power is the same as that of Example 10.3, i.e., 13.06 W.



(a) Circuit



(b) Control voltage

FIGURE 10.11 L-type ZCSC. (a) Circuit, (b) control voltage.

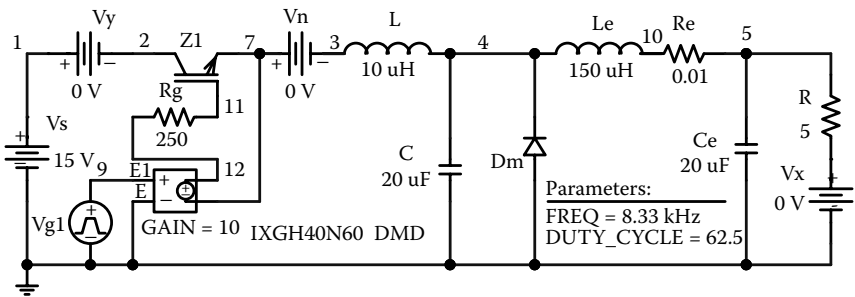


FIGURE 10.12 PSpice schematic for Example 10.4.

### 10.4 ZERO-VOLTAGE SWITCHING CONVERTER (ZVSC)

A power device of a ZVSC is turned on when its voltage becomes zero because of the resonant oscillation. At zero voltage, the resonant current becomes maximum. The device remains on and supplies the load current. The switching period must be long enough to complete the resonant oscillation.

#### EXAMPLE 10.5 FINDING THE PERFORMANCE OF A ZERO-VOLTAGE SWITCHING INVERTER

A ZVSC is shown in Figure 10.14(a). The control voltage is shown in Figure 10.14(b). The DC input voltage is  $V_s = 15\text{ V}$ . The switching frequency is  $f_s = 2.5\text{ kHz}$ . Use PSpice to plot the instantaneous capacitor voltage  $v_c$ , the inductor current  $i_L$ , the diode current  $v_{Dm}$ , and the load voltage  $v_L$ . Use a voltage-controlled switch to perform the switching action.

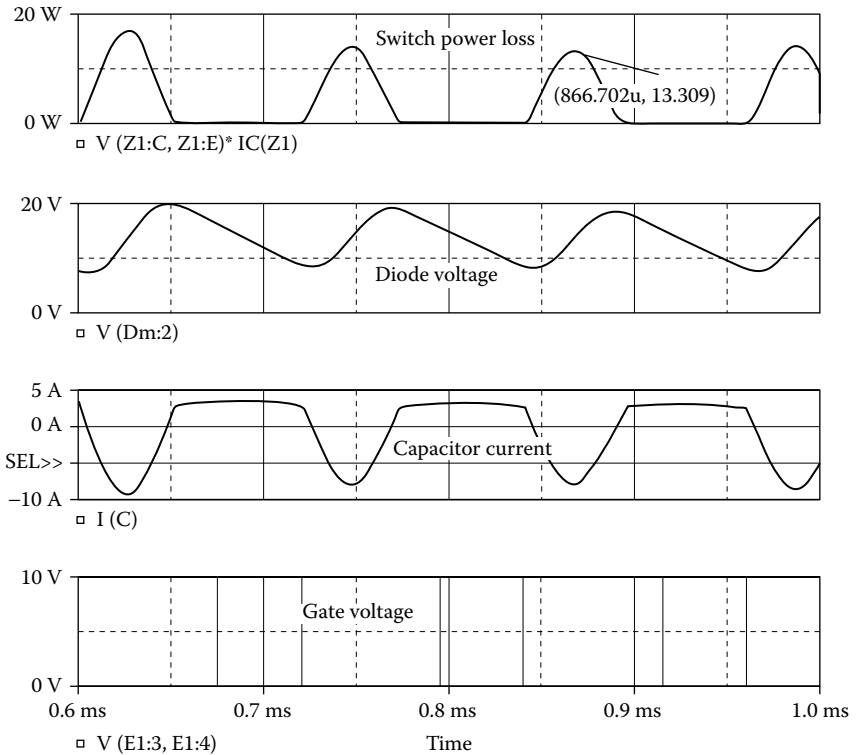


FIGURE 10.13 Plots for Example 10.4.

### SOLUTION

$V_g = 1/2.5 \text{ kHz} = 400 \text{ } \mu\text{sec}$ . The PSpice schematic with an IGBT switch is shown in Figure 10.15. The voltage-controlled voltage source  $E_1$  isolates the IGBT gate from the input gate signal  $V_g$ . The switching frequency and the duty cycle can be varied by changing the parameters {Freq} and {Duty\_Cycle}. The model parameters for the IGBT switch are as follows:

```
.MODEL IXGH40N60 NIGBT (TAU=287.56E-9 KP=50.034
AREA=37.500E-6 AGD=18.750E-6
+ VT=4.1822 KF=.36047 CGS=31.942E-9 COXD=53.188E-9
VTD=2.6570) for IGBTs
```

The listing of the circuit file is as follows:

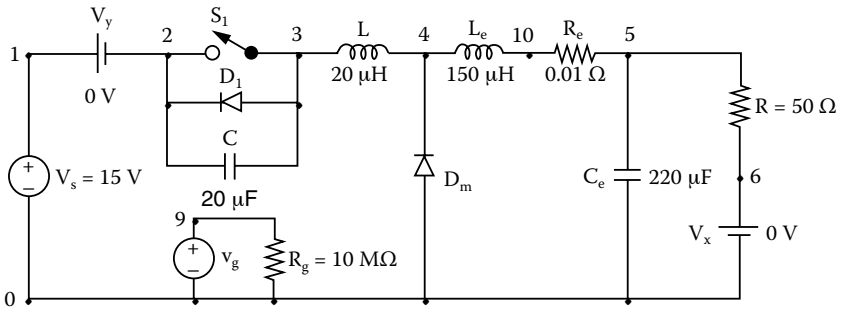
### Example 10.5 ZVSC

**SOURCE** ■ VS 1 0 DC 15V

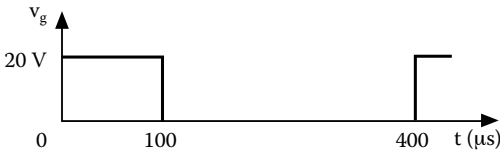
```
.PARAM Freq=2.5kHz Duty_Cycle=25
```

```

Rg 9 0 10MEG ; Control voltage
Vg 9 0 PULSE (0 1 0 1ns 1ns {{Duty_Cycle}/(100*
{Freq})-2ns} {1/{Freq}})
CIRCUIT ■■ VY 1 2 DC 0V ; Voltage source to measure supply current
VX 6 0 DC 0V ; Measures load current
R 5 6 50
LE 4 10 150UH
RE 10 5 0.01
CE 5 0 220UF
L 3 4 20UH
C 2 3 20UF
D1 3 2 DMOD ; Diode
DM 0 4 DMOD ; Diode
.MODEL DMOD D (IS=2.2E-15 BV=1200V CJO=0 TT=0) ; Diode
model parameters
S1 2 3 9 0 SMOD ; Voltage-controlled switch
.MODEL SMOD VSWITCH (RON=0.01 ROFF=10E+6 VON=1V VOFF=0V)
ANALYSIS ■■■ .TRAN 1US 1.6MS 0.40MS ; Transient analysis
.PROBE ; Graphics post-processor
.OPTIONS ABSTOL = 1.00 NRELTOL = 0.1 VNTOL=0.1I
TL5=50000
.END
    
```



(a) Circuit



(b) Control voltage

**FIGURE 10.14** ZVSC. (a) Circuit, (b) control voltage.

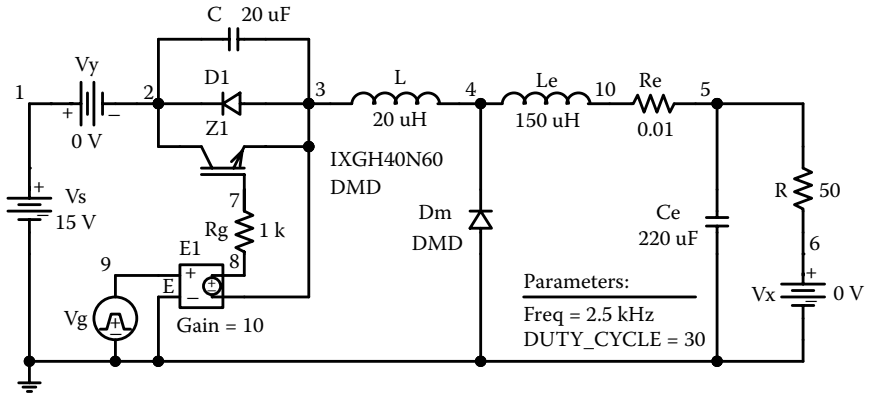


FIGURE 10.15 PSpice schematic for Example 10.5.

The PSpice plots of the instantaneous capacitor voltage  $V(2,4)$ , the inductor current  $I(L)$ , the diode voltage  $V(4)$ , and the load voltage  $V(5)$  are shown in Figure 10.16.

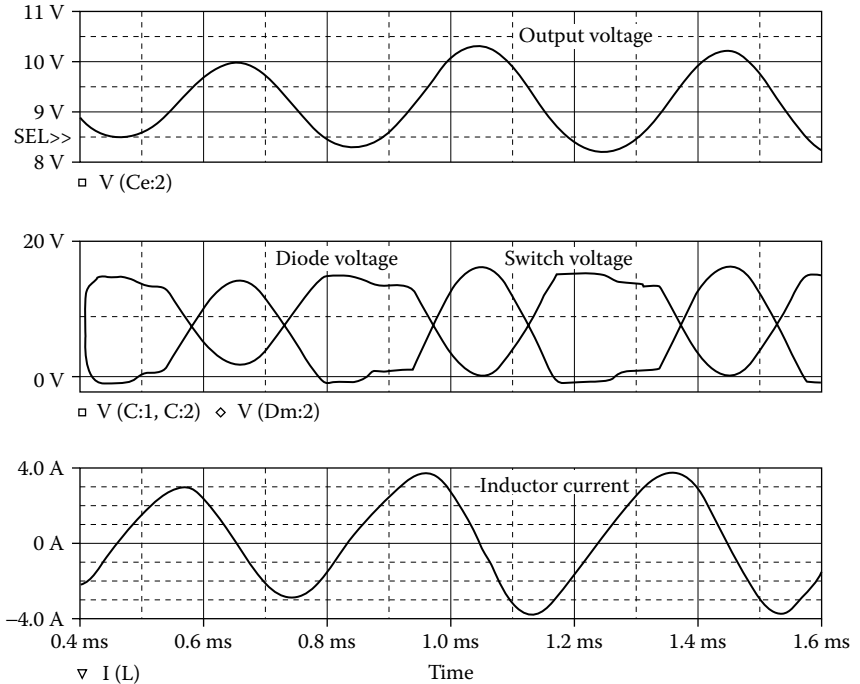


FIGURE 10.16 Plots for Example 10.5.

## 10.5 LABORATORY EXPERIMENTS

It is possible to develop many experiments to demonstrate the operation and characteristics of inverters. The following experiments are suggested:

Single-phase half-bridge resonant inverter  
 Single-phase full-bridge resonant inverter  
 Push–pull inverter  
 Parallel resonant inverter  
 ZCSC  
 ZVSC

### 10.5.1 EXPERIMENT RI.1

#### Single-Phase Half-Bridge Resonant Inverter

<b>Objective</b>	To study the operation and characteristics of a single-phase half-bridge resonant (transistor) inverter.
<b>Applications</b>	The resonant inverter is used to control power flow in AC and DC power supplies, input stages of other converters, etc.
<b>Textbook</b>	See <a href="#">Reference 1</a> , Section 8.2.
<b>Apparatus</b>	<ol style="list-style-type: none"> <li>Two BJTs or MOSFETs with ratings of at least 50 A and 400 V, mounted on heat sinks</li> <li>Two fast-recovery diodes with ratings of at least 50 A and 400 V, mounted on heat sinks</li> <li>A firing pulse generator with isolating signals for gating transistors</li> <li>An <math>RL</math> load</li> <li>One dual-beam oscilloscope with floating or isolating probes</li> <li>AC and DC voltmeters and ammeters and one noninductive shunt</li> </ol>
<b>Warning</b>	Before making any circuit connection, switch the DC power off. Do not switch on the power unless the circuit is checked and approved by your laboratory instructor. Do not touch the transistor or diode heat sinks, which are connected to live terminals.
<b>Experimental procedure</b>	<ol style="list-style-type: none"> <li>Set up the circuit as shown in <a href="#">Figure 10.17</a>. Use an <math>RLC</math> load. Design suitable values of snubbers.</li> <li>Connect the measuring instruments as required.</li> <li>Connect the firing pulses to the appropriate transistors.</li> <li>Set the duty cycle to <math>k = 0.5</math>.</li> <li>Observe and record the waveforms of the load voltage <math>v_o</math> and the load current <math>i_o</math>.</li> <li>Measure the rms load voltage, the rms load current, the average input current, the average input voltage, and the total harmonic distortion of the output voltage and current.</li> <li>Measure the conduction angles of the transistor <math>Q_1</math> and diode <math>D_1</math>.</li> </ol>
<b>Report</b>	<ol style="list-style-type: none"> <li>Present all recorded waveforms and discuss all significant points.</li> <li>Compare the waveforms generated by SPICE with the experimental results, and comment.</li> <li>Compare the experimental results with the predicted results.</li> <li>Discuss the advantages and disadvantages of this type of inverter.</li> <li>Discuss the effects of the diodes on the performance of the inverter.</li> </ol>

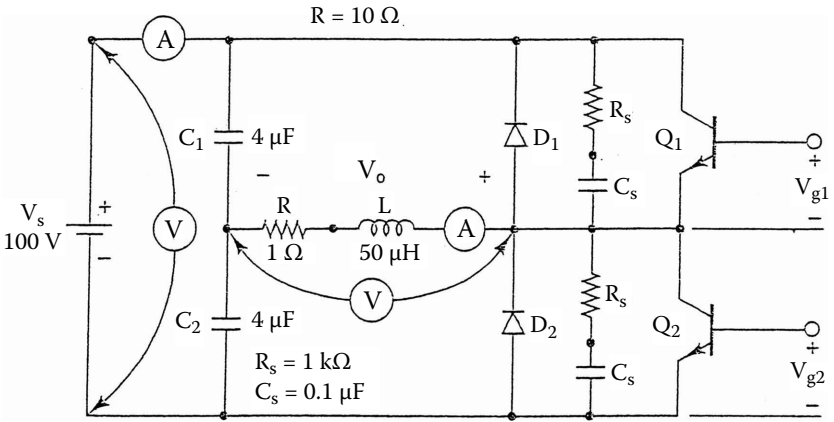


FIGURE 10.17 Single-phase half-bridge resonant inverter.

10.5.2 EXPERIMENT RI.2

Single-Phase Full-Bridge Resonant Inverter

- Objective** To study the operation and characteristics of a single-phase full-bridge resonant (transistor) inverter.
- Applications** The resonant inverter is used to control power flow in high-frequency applications, AC and DC power supplies, input stages of other converters, etc.
- Textbook** See Reference 1, Section 8.2.
- Apparatus** See Experiment RI.1.
- Warning** See Experiment RI.1
- Experimental procedure** Set up the circuit as shown in Figure 10.18. Repeat the steps in Experiment RI.1.
- Report** See Experiment RI.1.

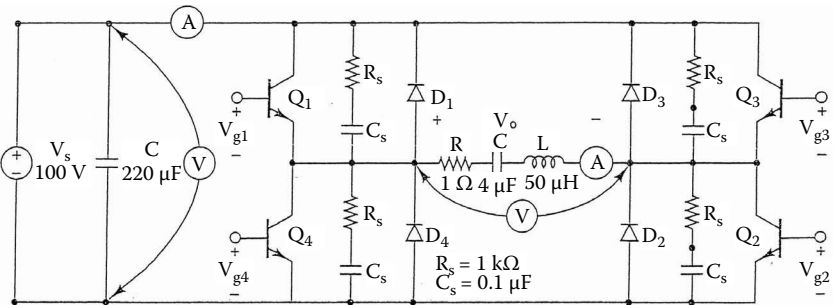


FIGURE 10.18 Single-phase full-bridge resonant inverter.

### 10.5.3 EXPERIMENT RI.3

#### Push–Pull Inverter

<b>Objective</b>	To study the operation and characteristics of a push–pull (transistor) inverter.
<b>Applications</b>	The push–pull inverter is used to control power flow in high-frequency applications, AC and DC power supplies, input stages of other converters, etc.
<b>Textbook</b>	See Reference 1, Section 8.2.
<b>Apparatus</b>	See Experiment RI.1.
<b>Warning</b>	See Experiment RI.1.
<b>Experimental procedure</b>	Set up the circuit as shown in Figure 10.19. Repeat the steps of Experiment RI.1.
<b>Report</b>	See Experiment RI.1.

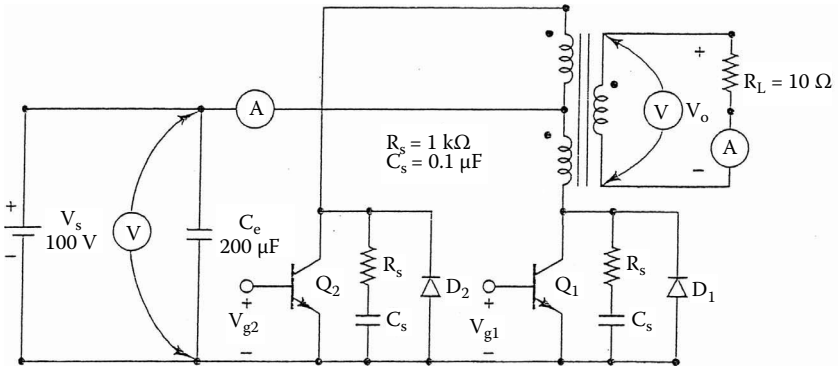


FIGURE 10.19 Push–pull inverter.

### 10.5.4 EXPERIMENT RI.4

#### Parallel Resonant Inverter

<b>Objective</b>	To study the operation and characteristics of a single phase push–pull parallel resonant (transistor) inverter.
<b>Applications</b>	The parallel resonant inverter is used to control power flow in high-frequency applications, AC and DC power supplies, input stages of other converters, etc.
<b>Textbook</b>	See Reference 1, Section 8.3.
<b>Apparatus</b>	See Experiment RI.1.
<b>Warning</b>	See Experiment RI.1.
<b>Experimental procedure</b>	Set up the circuit as shown in Figure 10.20. Repeat the steps of Experiment RI.1.
<b>Report</b>	See Experiment RI.1.

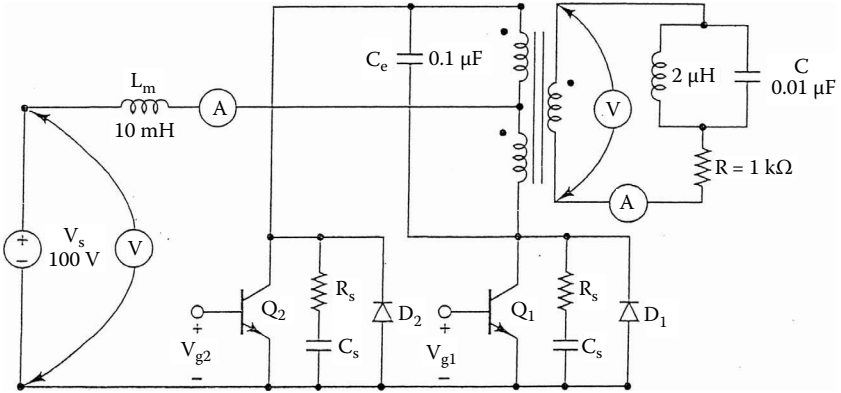


FIGURE 10.20 Parallel resonant inverter.

## 10.5.5 EXPERIMENT RI.5

### ZCSC

#### Objective

To study the operation and characteristics of a ZCSC.

#### Applications

The ZCSC is used to control power flow in AC and DC power supplies, etc.

#### Textbook

See [Reference 1](#), Section 8.6.

#### Apparatus

1. One BJT or MOSFET with ratings of at least 50 A and 400 V, mounted on a heat sink
2. One fast-recovery diode with ratings of at least 50 A and 400 V, mounted on a heat sink
3. A firing pulse generator with isolating signals for gating transistor
4. An  $R$  load, capacitors, and chokes
5. One dual-beam oscilloscope with floating or isolating probes
6. AC and DC voltmeters and ammeters and one noninductive shunt

#### Warning

See [Experiment RI.1](#).

#### Experimental procedure

1. Set up the circuit as shown in [Figure 10.21](#).
2. Connect the measuring instruments as required.
3. Connect the firing pulses to the appropriate transistors.
4. Set the duty cycle to  $k = 0.5$ .
5. Observe and record the waveforms of the load voltage  $v_o$ , the currents through  $C$ ,  $L$ , and  $Q_1$ , and the voltage across diode  $D_m$ .
6. Measure the average output voltage, the average output current, the average input current, and the average input voltage.
7. Measure the conduction angles of transistor  $Q_1$ .
8. Repeat steps 2 to 7 for the circuit of [Figure 10.22](#).

#### Report

See [Experiment RI.1](#).

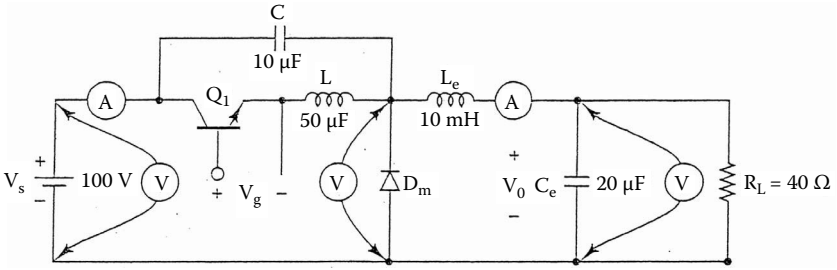


FIGURE 10.21 First ZCSC circuit for Experiment RI.5.

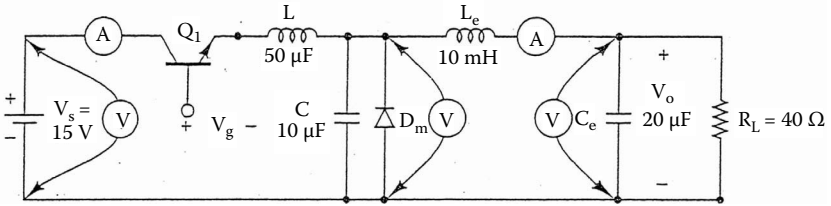


FIGURE 10.22 Second ZCSC circuit for Experiment RI.5.

### 10.5.6 EXPERIMENT RI.6

#### ZVSC

- Objective** To study the operation and characteristics of a ZVSC.
- Applications** The ZVSC is used to control power flow in AC and DC power supplies, etc.
- Textbook** See Reference 1, Section 8.7.
- Apparatus** See Experiment RI.5.
- Warning** See Experiment RI.1.
- Experimental procedure** Set up the circuit as shown in Figure 10.23. See Experiment RI.5.
- Report** See Experiment RI.1.

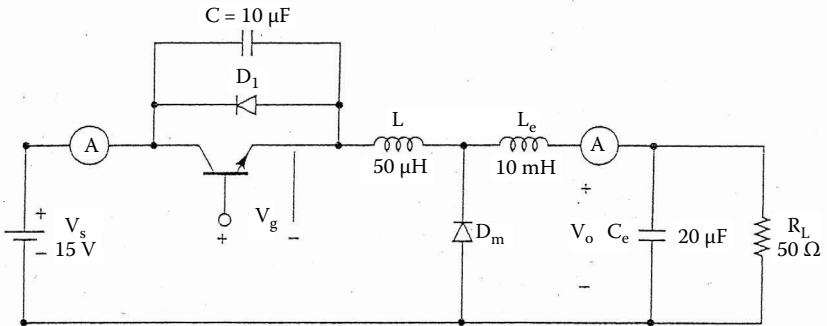


FIGURE 10.23 ZVSC.

## 10.6 SUMMARY

The statements for an AC thyristor are:

\* Subcircuit call for switched transistor model:

```
XT1  +N          -N          +NG          -NG          QM
      positive  negative  +control  -control  model
*
      voltage   voltage   name
```

\* Subcircuit call for PWM control:

```
XPWM  VR      VC          +NG          -NG          PWM
*      ref.  carrier  +control  -control  model
*      input input  voltage  voltage  name
```

\* Subcircuit call for sinusoidal PWM control:

```
XSPWM VR      VS          +NG          -NG          VC          SPWM
*      ref.  sine-wave  +control  -control  rectified  model
*      input  input  voltage  voltage  carrier sine wave  name
```

## Suggested Reading

1. M. R. Rashid, *Power Electronics: Circuits, Devices, and Applications*, 2nd ed. Englewood Cliffs, NJ: Prentice Hall, 2003, chap. 8.
2. N. Mohan, T.M. Undeland, and W.P. Robbins, *Power Electronics: Converters, Applications, and Design*, New York: John Wiley & Sons, 2003.

## DESIGN PROBLEMS

### 10.1

It is required to design the single-phase half-bridge resonant inverter of [Figure 10.17](#) with the following specifications:

DC supply voltage,  $V_s = 100$  V

Load resistance,  $R = 1 \Omega$

Load inductance,  $L = 100 \mu\text{H}$

Output frequency should be as high as possible

- (a) Determine the ratings of all components and devices under worst-case conditions.
- (b) Use SPICE to verify your design.
- (c) Provide a cost estimate of the circuit.

## 10.2

It is required to design the single-phase full-bridge resonant inverter of [Figure 10.18](#) with the following specifications:

- DC supply voltage,  $V_s = 100 \text{ V}$
- Load resistance,  $R = 1 \ \Omega$
- Load inductance,  $L = 50 \ \mu\text{H}$
- Load capacitance,  $C = 4 \ \mu\text{F}$
- Output frequency should be as high as possible

- (a) Determine the ratings of all components and devices under worst-case conditions.
- (b) Use SPICE to verify your design.
- (c) Provide a cost estimate of the circuit.

## 10.3

It is required to design the push-pull inverter of [Figure 10.19](#) with the following specifications:

- DC supply voltage,  $V_s = 100 \text{ V}$
- Load resistance,  $R = 100 \ \Omega$
- Peak value of load voltage,  $V_p = 140 \text{ V}$
- Output frequency,  $f_o = 1 \text{ kHz}$

- (a) Determine the ratings of all components and devices under worst-case conditions.
- (b) Use SPICE to verify your design.
- (c) Provide a cost estimate of the circuit.

## 10.4

It is required to design the parallel resonant inverter of [Figure 10.20](#) with the following specifications:

- DC supply voltage,  $V_s = 100 \text{ V}$
- Load resistance,  $R = 1 \ \text{k}\Omega$
- Load inductance,  $L = 2 \ \mu\text{H}$
- Load capacitance,  $C = 0.1 \ \mu\text{F}$
- Peak value of load voltage,  $V_p = 140 \text{ V}$

- (a) Determine the ratings of all components and devices under worst-case conditions.
- (b) Use SPICE to verify your design.
- (c) Provide a cost estimate of the circuit.

## 10.5

It is required to design the ZCSC of [Figure 10.21](#) with the following specifications:

DC supply voltage,  $V_s = 20 \text{ V}$

Load resistance,  $R = 100 \ \Omega$

Average output voltage,  $V_{(DC)} = 10 \text{ V}$  with  $\pm 5\%$  ripple

- Determine the ratings of all components and devices under worst-case conditions.
- Use SPICE to verify your design.
- Provide a cost estimate of the circuit.

## 10.6

It is required to design the ZCSC of [Figure 10.22](#) with the following specifications:

DC supply voltage,  $V_s = 20 \text{ V}$

Load resistance,  $R = 100 \ \Omega$

Average output voltage,  $V_{(DC)} = 10 \text{ V}$  with  $\pm 5\%$  ripple

- Determine the ratings of all components and devices under worst-case conditions.
- Use SPICE to verify your design.
- Provide a cost estimate of the circuit.

## 10.7

It is required to design the ZVSC of [Figure 10.23](#) with the following specifications:

DC supply voltage,  $V_s = 20 \text{ V}$

Load resistance,  $R = 100 \ \Omega$

Average output voltage,  $V_{(DC)} = 10 \text{ V}$  with  $\pm 5\%$  ripple

- Determine the ratings of all components and devices under worst-case conditions.
- Use SPICE to verify your design.
- Provide a cost estimate of the circuit.

## 10.8

Use PSpice to find the worst-case minimum and maximum DC output voltages  $V_{o(\max)}$  and  $V_{o(\min)}$  for Problem 10.1. Assume uniform tolerances of  $\pm 15\%$  for all passive elements and an operating temperature of  $25^\circ\text{C}$ .

**10.9**

Use PSpice to find the worst-case minimum and maximum DC output voltages  $V_{o(\max)}$  and  $V_{o(\min)}$  for Problem 10.2. Assume uniform tolerances of  $\pm 15\%$  for all passive elements and an operating temperature of  $25^\circ\text{C}$ .

**10.10**

Use PSpice to find the worst-case minimum and maximum DC output voltages  $V_{o(\max)}$  and  $V_{o(\min)}$  for Problem 10.3. Assume uniform tolerances of  $\pm 15\%$  for all passive elements and an operating temperature of  $25^\circ\text{C}$ .

**10.11**

Use PSpice to find the worst-case minimum and maximum DC output voltages  $V_{o(\max)}$  and  $V_{o(\min)}$  for Problem 10.4. Assume uniform tolerances of  $\pm 15\%$  for all passive elements and an operating temperature of  $25^\circ\text{C}$ .

**10.12**

Use PSpice to find the worst-case minimum and maximum DC output voltages  $V_{o(\max)}$  and  $V_{o(\min)}$  for Problem 10.5. Assume uniform tolerances of  $\pm 15\%$  for all passive elements and an operating temperature of  $25^\circ\text{C}$ .

**10.13**

Use PSpice to find the worst-case minimum and maximum DC output voltages  $V_{o(\max)}$  and  $V_{o(\min)}$  for Problem 10.6. Assume uniform tolerances of  $\pm 15\%$  for all passive elements and an operating temperature of  $25^\circ\text{C}$ .

**10.14**

Use PSpice to find the worst-case minimum and maximum DC output voltages  $V_{o(\max)}$  and  $V_{o(\min)}$  for Problem 10.7. Assume uniform tolerances of  $\pm 15\%$  for all passive elements and an operating temperature of  $25^\circ\text{C}$ .

---

# 11 Controlled Rectifiers

The learning objectives of this chapter are:

- Modeling SCRs and specifying their mode parameters
- Modeling voltage-controlled switches
- Performing transient analysis of controlled rectifiers
- Evaluating the performance of controlled rectifiers
- Performing worst-case analysis of resonant-pulse inverters for parametric variations of model parameters and tolerances

## 11.1 INTRODUCTION

A thyristor can be turned on by applying a pulse of short duration. Once the thyristor is on, the gate pulse has no effect, and it remains on until its current is reduced to zero. It is a latching device. Pulse-width modulation (PWM) techniques can be applied to controlled rectifiers with bidirectional switches in order to improve the input power factor of the converters.

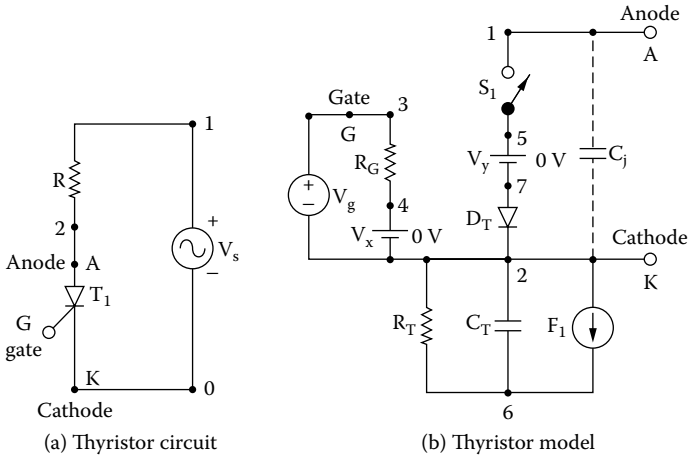
## 11.2 AC THYRISTOR MODEL

There are a number of published AC thyristor models [3–6]. We shall use a very simple model that can be used to obtain the various waveforms of controlled rectifiers. Let us assume that the thyristor shown in [Figure 11.1\(a\)](#) is operated from an AC supply. This thyristor should exhibit the following characteristics:

1. It should switch to the on-state with the application of a small positive gate voltage, provided that the anode-to-cathode voltage is positive.
2. It should remain in the on-state for as long as the anode current flows.
3. It should switch to the off-state when the anode current goes through zero in the negative direction.

The switching action of the thyristor can be modeled by a voltage-controlled switch and a polynomial current source [3]. This is shown in [Figure 11.1\(b\)](#). The turn-on process can be explained by the following steps:

1. For a positive gate voltage  $V_g$  between nodes 3 and 2, the gate current is  $I_g = I(VX) = V_g/R_G$ .
2. The gate current  $I_g$  activates the current-controlled current source  $F_1$  and produces a current of value  $F_g = P_1 I_g = P_1 \times I(VX)$ , such that  $F_1 = F_g + F_a$ .



**FIGURE 11.1** AC thyristor model. (a) Thyristor circuit, (b) thyristor model.

3. The current source  $F_g$  produces a rapidly rising voltage  $V_R$  across resistance  $R_T$ .
4. As the voltage  $V_R$  increases above zero, the resistance  $R_S$  of the voltage-controlled switch  $S_1$  decreases from  $R_{OFF}$  toward  $R_{ON}$ .
5. As the switch resistance  $R_S$  decreases, the anode current  $I_a = I(VY)$  increases, provided that the anode-to-cathode voltage is positive. This increasing anode current  $I_a$  produces a current  $F_a = P_2 I_a = P_2 \times I(VY)$ . This causes the value of voltage  $V_R$  to increase.
6. This then produces a regenerative condition with the switch rapidly being driven into low resistance (the on-state). The switch remains on if the gate voltage  $V_g$  is removed.
7. The anode current  $I_a$  continues to flow as long as it is positive, and the switch remains in the on-state.

During turn-off, the gate current is off and  $I_g = 0$ . That is,  $I_g = 0$  and  $F_g = 0$ ,  $F_1 = F_g + F_a = F_a$ . The turn-off operation can be explained by the following steps:

1. As the anode current  $I_a$  goes negative, the current  $F_1$  reverses provided that the gate voltage  $V_g$  is no longer present.
2. With a negative  $F_1$ , the capacitor  $C_T$  discharges through the current source  $F_1$  and the resistance  $R_T$ .
3. With the fall of voltage  $V_R$  to a low level, the resistance  $R_S$  of switch  $S_1$  increases from a low ( $R_{ON}$ ) value to a high ( $R_{OFF}$ ) value.
4. This is, again, a regenerative condition with the switch resistance being driven rapidly to an  $R_{OFF}$  value as the voltage  $V_R$  becomes zero.

This model works well with a converter circuit in which the thyristor current falls to zero itself: for example, in half-wave controlled rectifiers and AC voltage

controllers. But in full-wave converters with a continuous load current, the current of a thyristor is diverted to another thyristor, and this model may not give the true output. This problem can be remedied by adding diode  $D_T$  as shown in Figure 11.1(b). The diode prevents reverse current flow through the thyristor resulting from the firing of another thyristor in the circuit.

Let us consider the thyristor whose data sheets are shown in Figure 11.2. Suitable values of the model parameters can be chosen to satisfy the characteristics of a particular thyristor by the following steps:

**S18CF SERIES**  
**1200–1000 VOLTS RANGE**  
**STANDARD TURN-OFF TIME 16  $\mu$ s**  
**110 AMP RMS, CENTER AMPLIFYING GATE**  
**INVERTER TYPE STUD MOUNTED SCRs**

**Voltage ratings**

Voltage code (1)	$V_{RRM}, V_{DRM} - (V)$ Max. rep. peak reverse and off-state voltage	$V_{RSH} - (V)$ Max. non-rep. peak-reverse voltage $t_p \leq 5$ ms	Notes
	$T_J = -40^\circ$ to $125^\circ C$	$T_J = 25^\circ$ to $125^\circ C$	
12	1200	1300	Gate open
10	1000	1100	

**Maximum allowable ratings**

Parameter	Value	Units	Notes
$T_J$ Junction temperature	-40 to 125	$^\circ C$	
$T_{stg}$ Storage temperature	-40 to 150	$^\circ C$	
$I_T(AV)$ Max. av. current	70	A	180 $^\circ$ half sine wave
	Max. $T_C$	85	
$I_T(RMS)$ Max. RMS current	110	A	
$I_{TSM}$ Max. peak non-repetitive surge current	1910	A	50 Hz half cycle sine wave Initial $T_J = 125^\circ C$ , rated $V_{RRM}$ applied after surge.
	2000		60 Hz half cycle sine wave
	2270		50 Hz half cycle sine wave Initial $T_J = 125^\circ C$ , no voltage applied after surge.
	2380		60 Hz half cycle sine wave
$I^2 t$ Max. $I^2 t$ capability	18	$kA^2 s$	t = 10 ms Initial $T_J = 125^\circ C$ , rated $V_{RRM}$ applied after surge.
	17		t = 8.3 ms
	26		t = 10 ms Initial $T_J = 125^\circ C$ , on voltage applied after surge.
	24		t = 8.3 ms
$I^2 t$ Max. $I^2 t$ capability	258	$kA^2 \sqrt{s}$	Initial $T_J = 125^\circ C$ , on voltage applied after surge. $I^2 t$ for time $t_x = I^2 \int \sqrt{t_x} \cdot 0.1 \leq t_x \leq 10$ ms.
di/dt Max. non-repetitive rate-of rise of current	800	A/ $\mu$ s	$T_J = 125^\circ C, V_D = V_{DRM}, I_{TM} = 1600$ A, gate pulses: 20 V, 20 $\Omega$ , 10 $\mu$ s, 0.5 $\mu$ s rise time. Max. repetitive di/dt is approximately 40% of non-repetitive value.
$P_{GH}$ Max. peak gate power	10	W	$t_p \leq 5$ ms
$P_{G(AV)}$ Max. av. gate power	2	W	
$+I_{GM}$ Max. peak gate current	3	A	$t_p \leq 5$ ms
$-V_{GH}$ Max. peak negative gate voltage	15	V	
T Mounting torque	15.5 (137) $\pm$ 10%	N-m (tbf-in)	Non-lubricated threads
	14 (120) $\pm$ 10%		Lubricated threads

(1) To complete the part number, refer to the ordering information table.

**FIGURE 11.2** Data sheets for IR thyristors type S18. (Courtesy of International Rectifier.)

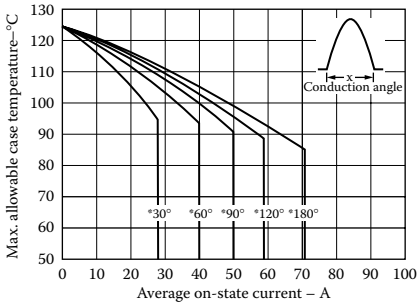
**S18CF SERIES**  
**1200–1000 VOLTS RANGE**

**Characteristics**

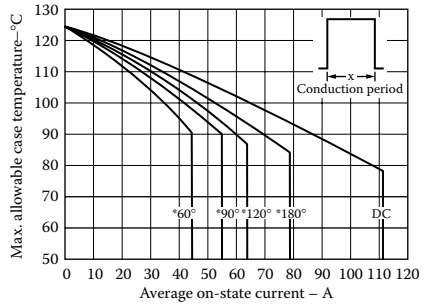
Parameter	Min.	Typ.	Max.	Units	Test conditions	
$V_{TM}$	Peak on-state voltage	—	1.95	2.06	V	Initial $T_J = 25^\circ\text{C}$ , 50–60 Hz half sine, $I_{peak} = 220\text{ A}$ .
$V_{T(TO)1}$	Low-level threshold	—	—	1.28	V	$T_J = 125^\circ\text{C}$ Av. power = $V_{T(TO)} \cdot I_{T(AV)} + r_T \cdot [I_{T(RHS)}]^2$
$V_{T(TO)2}$	High-level threshold	—	—	1.61		
$rT_1$	Low-level threshold	—	—	3.54	m $\Omega$	Use low level values for $I_{TH} \approx \pi$ rated $I_{T(AV)}$
$rT_2$	High-level threshold	—	—	2.27		
$I_L$	Latching current	—	270	—	ma	$T_C = 25^\circ\text{C}$ , 12 V anode. gate pulse: 10 V, 20 $\Omega$ , 100 $\mu\text{s}$ .
$I_H$	Holding current	—	90	500	ma	$T_C = 25^\circ\text{C}$ , 12 V anode. Initial $I_T = 3\text{ A}$ .
$t_d$	Delay time	—	0.5	1.5	$\mu\text{s}$	$T_C = 25^\circ\text{C}$ , $V_D =$ rated $V_{DRH}$ . 50 A resistive load. gate pulse: 10 V, 20 $\Omega$ , 10 $\mu\text{s}$ , 1 $\mu\text{s}$ rise time
$t_q$	Turn-off time	—	—	—	$\mu\text{s}$	$T_J = 125^\circ\text{C}$ , $I_{TM} = 200\text{ A}$ , $di_R/dt = 10\text{ A}/\mu\text{s}$ , $V_R = 50\text{ V}$ , $dv/dt = 200\text{ V}/\mu\text{s}$ line to 80% rated $V_{DRM}$ . Gate: 0 V, 100 $\Omega$ .
	"A" suffix	—	—	16		
	"B" suffix	—	—	20		
$t_q(\text{diode})$	Turn-off time with feedback diode	—	—	—	$\mu\text{s}$	$T_J = 125^\circ\text{C}$ , $I_{TM} = 200\text{ A}$ , $di_R/dt = 10\text{ A}/\mu\text{s}$ , $V_R = 1\text{ V}$ , $dv/dt = 600\text{ V}/\mu\text{s}$ line to 40% rated $V_{DRM}$ . Gate: 0 V, 100 $\Omega$ .
	"A" suffix	—	—	20		
	"B" suffix	—	—	25		
$I_{RM(REC)}$	Recovery current	—	57	—	A	$T_J = 125^\circ\text{C}$ , $I_{TM} = 400\text{ A}$ , $di_R/dt = 50\text{ A}/\mu\text{s}$ .
$O_{RR}$	Recovery charge	—	58	—	$\mu\text{C}$	
$dv/dt$	Critical rate-of-rise of off-state voltage	500	700	—	V/ $\mu\text{s}$	$T_J = 125^\circ\text{C}$ . Exp. to 100% or lin. Higher $dv/dt$ values to 80% $V_{DRM}$ gets open, available.
		1000	—	—		$T_J = 125^\circ\text{C}$ . Exp. to 67% $V_{DRH}$ gets open.
$I_{RH}$ $I_{DM}$	Peak reverse and off-state current	—	10	20	mA	$T_J = 125^\circ\text{C}$ . Rated $V_{RRM}$ and $V_{DRM}$ gets open.
$I_{GT}$	DC gate voltage to trigger	—	—	300	mA	$T_C = -40^\circ\text{C}$ +12 V anode-to-cathode. For recommended gate drive see "Gate Characteristic" figure. $T_C = 25^\circ\text{C}$
		25	20	150		
$V_{GT}$	DC gate current to trigger	—	—	3.3	V	$T_C = -40^\circ\text{C}$ $T_C = 25^\circ\text{C}$
		—	1.2	2.5		
$V_{GD}$	DC gate voltage not to trigger	—	—	0.3	V	$T_C = 125^\circ\text{C}$ . Max. value which will not trigger with rated $V_{DRM}$ anode-to-cathode.
$R_{thJC}$	Thermal resistance, junction-to-case	—	—	0.250	$^\circ\text{C}/\text{W}$	DC operation
		—	—	0.291	$^\circ\text{C}/\text{W}$	180° sine wave
		—	—	0.302	$^\circ\text{C}/\text{W}$	120° rectangular wave
$R_{thCS}$	Thermal resistance, junction-to-case	—	—	0.100	$^\circ\text{C}/\text{W}$	Mtg. surface smooth, flat and greased.
wt	weight	—	100(3.5)	—	g(oz.)	
Case style		To-209AC (To-94)			JEDEC	

**FIGURE 11.2** (continued).

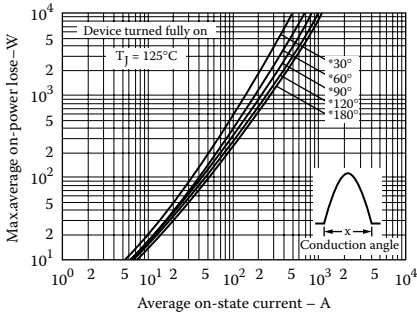
1. The switch parameters  $V_{ON}$  and  $V_{OFF}$  can be chosen arbitrarily. Let  $V_{ON} = 1\text{ V}$  and  $V_{OFF} = 0\text{ V}$ .
2.  $R_T$  can also be chosen arbitrarily. Let  $R_T = 1\ \Omega$ .
3.  $R_{ON}$  should be chosen to model the on-state resistance of the thyristor so that  $R_{ON} = V_{TM}/I_{TM}$  at  $25^\circ\text{C}$ . From the on-state characteristic of the data sheet,  $V_{TM} = 2\text{ V}$  at  $I_{TM} = 190\text{ A}$ . Thus,  $R_{ON} = 2/190 = 0.0105\ \Omega$ .
4.  $R_{OFF}$  should be chosen to model the off-state resistance of the thyristor so that  $R_{OFF} = V_{RRM}/I_{DRM}$  at  $25^\circ\text{C}$ . From the data sheet,  $V_{RRM} = 1200\text{ V}$  at  $I_{DRM} = 10\text{ mA}$ . Thus,  $R_{OFF} = 1200/(10 \times 10^{-3}) = 120\text{ k}\Omega$ .
5. The switch resistance  $R_S$  can be found from



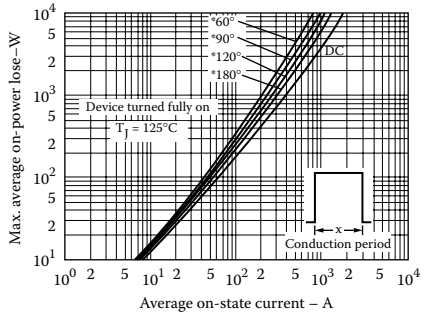
(c)



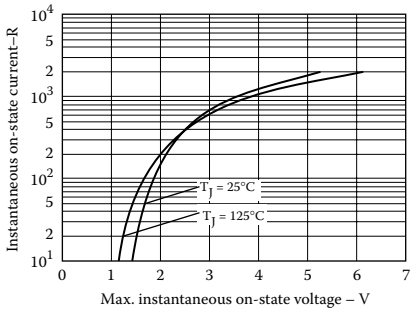
(d)



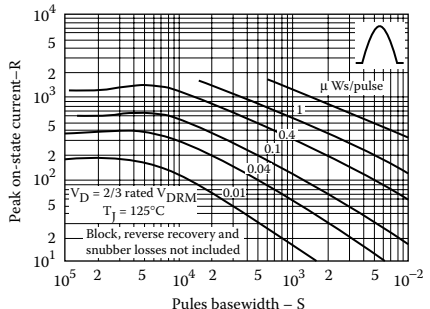
(e)



(f)



(g)



(h)

FIGURE 11.2 (continued).

$$R_S = R_{ON} \times \frac{R_{OFF}}{R_{ON}} \left[ 0.5 + 2 \left( V_R - 0.5 \frac{V_{ON} + V_{OFF}}{V_{ON} - V_{OFF}} \right)^3 - 1.5 \left( V_R - 0.5 \frac{V_{ON} + V_{OFF}}{V_{ON} - V_{OFF}} \right) \right] \quad (11.1)$$

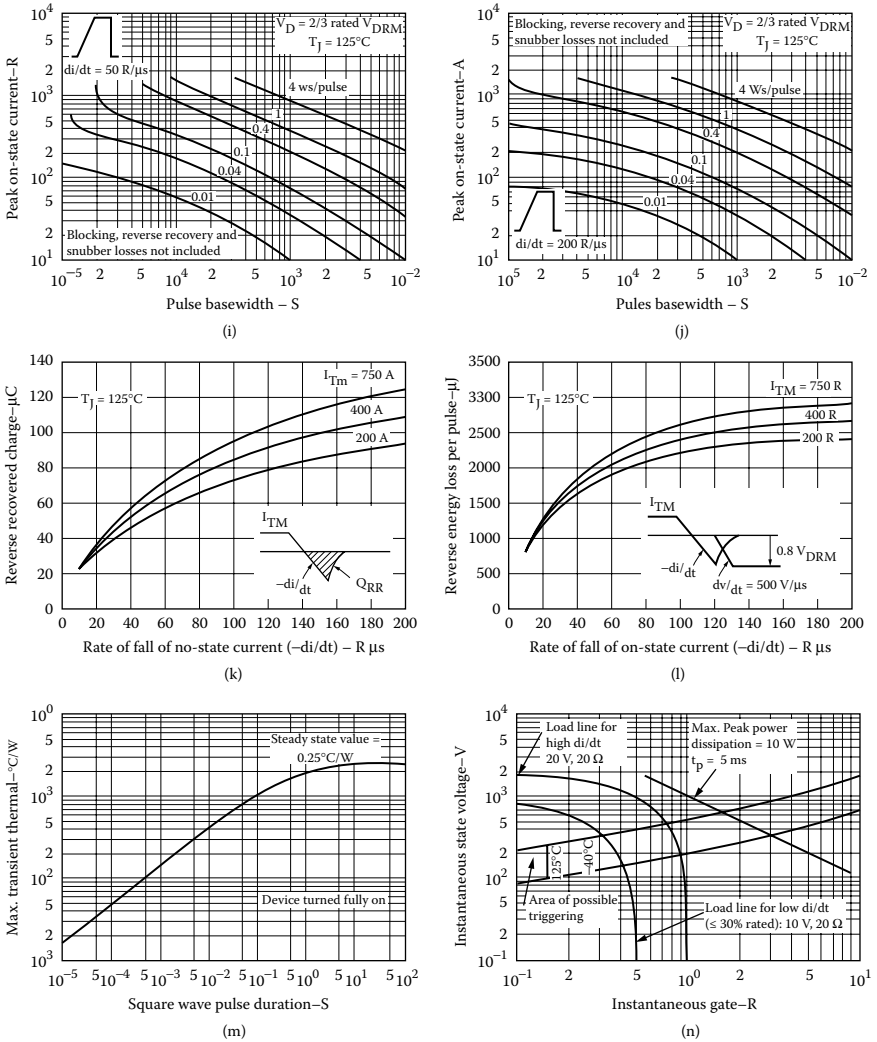
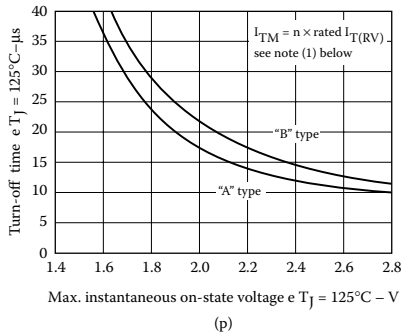
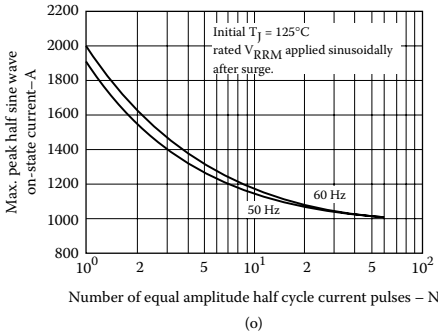


FIGURE 11.2 (continued).

- For  $V_R = 0$ ,  $R_S = R_{OFF}$ , and for  $V_R = 1$ ,  $R_S = R_{ON}$ . As  $V_R$  varies from 0 to 1 V, the switch resistance  $R_S$  changes from  $R_{OFF}$  to  $R_{ON}$ .
- The value of  $P_2$  must be such that the device turns off (with zero gate current  $I_g = 0$ ) at the maximum anode-to-cathode voltage  $V_{DRM}$ . If  $V_{R1}$  is 15% of  $V_R$ , that is,  $V_{R1} = 0.15 V_R$ , the switch will essentially be off. The voltage  $V_{R1}$  due to the anode current only is given by



(1) These curve are intended as a guideline. To specify non-standard  $t_q/v_{TM}$  contact factory.

Ordering information

Type	Package (1)		Fast	Temperature		Voltage		Turn-off		Leads &-terminals	
	Code	Description		Code	Max. T <sub>j</sub>	Code	V <sub>DRM</sub>	Code	Max. T <sub>q</sub>	Code	Description
S18	C	1/2" stud, ceramic housing.	F	—	125°C	12	1200 V	A	16 μs	0	Flexible leads, ayelet terminals. standard in USA. (fig. 1)
						10	1000 V	B	20 μs	1	Flexible leads, fast-on terminals. standard in europe. (fig. 2)

(1) Other packages are also available:  
 - Supplied with flag terminals.  
 For further details contact factory.

For a device with standerd USA case, max T<sub>j</sub> = 125°C, V<sub>DRM</sub> = 1200 V, max. t<sub>q</sub> = 16 μm, order as: S1BCF12AD.

FIGURE 11.2 (continued).

$$V_{R1} < P_2 I_a = P_2 \frac{V_{DRM}}{R_{S1}} \tag{11.2}$$

$$P_2 > \frac{V_{R1} R_{S1}}{V_{DRM}}$$

At the latching current  $I_L$ , the switch must be fully on,  $V_R = 1$  V. That is,  $P_2 > V_{R1}/I_L$ . Thus, the value of  $P_2$  must satisfy the condition

$$\frac{V_R}{I_L} < P_2 < \frac{V_{R1} R_{S1}}{V_{DRM}} \tag{11.3}$$

From the data sheet,  $I_L = 270$  mA. That is,  $(1/270 \text{ mA}) < P_2 > (0.15 \times 120 \text{ k}\Omega/1200)$  or  $3.7 < P_2 > 15$ . Let us choose  $P_2 = 11$ .

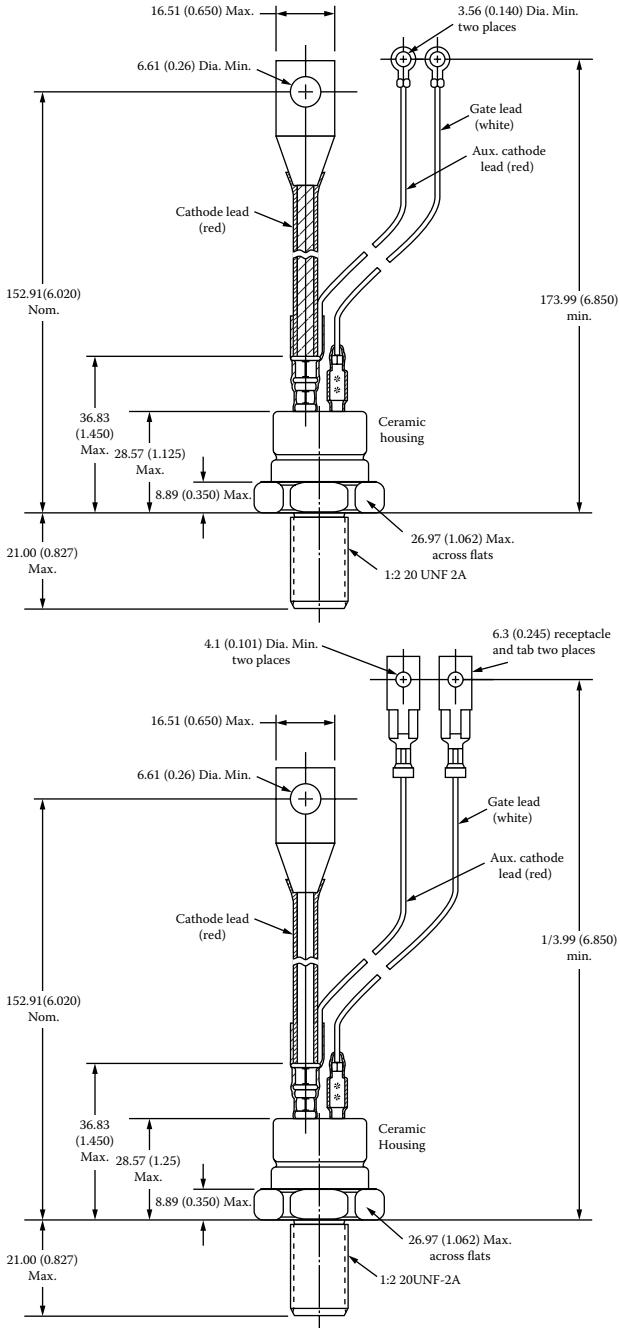


FIGURE 11.2 (continued).

7. The capacitor  $C_T$  is introduced primarily to facilitate SPICE convergence. If  $C_T$  is too small, the thyristor will go off before the anode current becomes zero. If  $C_T$  has a sufficiently large value, the thyristor will continue to conduct beyond the zero crossing of supply voltage, and  $C_R$  can be chosen large enough to model the turn-off time  $t_{off}$  of the thyristor. The time constant  $C_T R_T$  should be much smaller than the period  $T$  of the supply voltage. This condition is generally satisfied by the relation  $C_T R_T \leq 0.01T$ . Let us choose  $C_T = 10 \mu\text{F}$ .
8. As far as the model is concerned,  $R_G$  can be chosen arbitrarily. From the data sheet,  $V_g = 5 \text{ V}$  at  $I_g = 100 \text{ mA}$ . Therefore, we get  $R_G = V_g / I_g = 5/0.1 = 50 \Omega$ .
9. For a known value of  $R_G$ , the multiplier  $P_1$  can be determined from  $V_{ON} = R_T P_1 I_g$ , which gives

$$\begin{aligned}
 P_1 &= \frac{V_{ON}}{R_T I_g} = \frac{V_{ON}}{R_T V_{g(\text{peak})} / R_G} = \frac{V_{ON} R_G}{R_T V_{g(\text{peak})}} \\
 &= \frac{1 \times 50}{1 \times 5} = 10
 \end{aligned}
 \tag{11.4}$$

where  $V_{g(\text{peak})}$  is the peak voltage of the gate pulse. At the leading edge of the gate pulse, most of the controlling current  $F_1$  flows through  $C_T$ . Thus, the gate pulse must be applied for a sufficient time to cause on-triggering. The voltage  $v_{R2}$  due to gate triggering only (with zero anode current) is given by

$$v_{R2} = R_T P_1 I_g (1 - e^{-t/R_T C_T})
 \tag{11.5}$$

The time  $t = t_n$  at which  $v_{R2} = V_{ON}$  gives the turn-on delay of the thyristor. Due to the presence of  $C_T$ , the voltage  $v_{R2}$  will be delayed and will not be equal to  $V_{ON} = R_T P_1 I_g$  instantly. A higher value of  $P_1$  is required to turn on the thyristor. Taking five times more than the value given by Equation 11.4, let  $P_1 = 50$ .

This thyristor model can be used as a subcircuit. The switch  $S_1$  is controlled by the controlling voltage  $V_R$  connected between nodes 6 and 2. The switch and the diode parameters can be adjusted to yield the desired on-state drop of the thyristor. In the following examples, we shall use a superdiode with parameters  $IS = 2.2\text{E}15$ ,  $BV = 1200\text{V}$ ,  $TT = 0$ , and  $CJO = 0$  and the switch parameters  $RON = 0.0105$ ,  $ROFF = 10\text{E}+5$ ,  $VON = 0.5\text{V}$ , and  $VOFF = 0\text{V}$ . The subcircuit definition for the thyristor model *SCR* can be described as follows:

---

```

* Subcircuit for AC thyristor model
.SUBCKT SCRMOD 1 3 2
*      model  anode +control  cathode
*      name          voltage
    
```

```

S1 1 5 6 2 SMOD ; Switch
RG 3 4 50
VX 4 2 DC 0V
VY 5 7 DC 0V
DT 7 2 DMOD ; Switch diode
RT 6 2 1
CT 6 2 10UF
F1 2 6 POLY(2) VX VY 0 50 11
.MODEL SMOD VSWITCH (RON=0.0105 ROFF=10E+5 VON=0.5V VOFF=0V) ;
Switch model
.MODEL DMOD D(IS=2.2E-15 BV=1200V TT=0 CJO=0) ; Diode model
parameters
.ENDS SCRMOD ; Ends subcircuit definition

```

---

### 11.3 CONTROLLED RECTIFIERS

A controlled rectifier converts a fixed AC voltage to a variable DC voltage and uses thyristors as switching devices. The output voltage of an ideal rectifier should be pure DC and contain no harmonics or ripples. Similarly, the input current should be pure sine wave and contain no harmonics. That is, the total harmonic distortion (THD) of the input current and output voltage should be zero, and the input power factor should be unity.

### 11.4 EXAMPLES OF CONTROLLED RECTIFIERS

Let us apply the thyristor model of [Figure 11.1\(b\)](#) to the circuit of [Figure 11.3\(a\)](#). Thyristor  $T_1$  is turned on by the voltage  $V_g$  connected between the gate and cathode voltage. The gate voltage  $V_g$  is shown in [Figure 11.3\(b\)](#). The listing of the PSpice circuit file for determining the transient response is as follows:

---

#### AC thyristor circuit

```

SOURCE ■ VS 1 0 SIN (0 169.7V 60HZ)
      Vg 4 0 PULSE (0V 10V 2777.8US 1NS 1NS 100US 16666.7US)
CIRCUIT ■■ R 1 2 2.5
      VX 2 3 DC 0V ; Voltage source to measure the load current
      * Subcircuit call for thyristor model:
      XT1 3 0 4 0 SCRMOD ; Thyristor T1
ANALYSIS ■■■ .TRAN 1US 5MS ; Transient analysis from 0 to 5 ms
      .PROBE ; Graphics post-processor
      .END

```

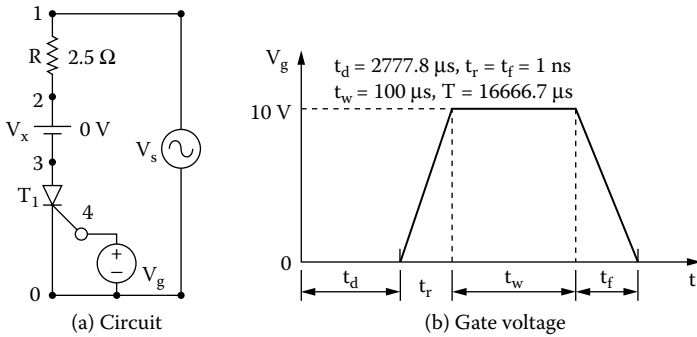


FIGURE 11.3 AC thyristor circuit. (a) Circuit, (b) gate voltage.

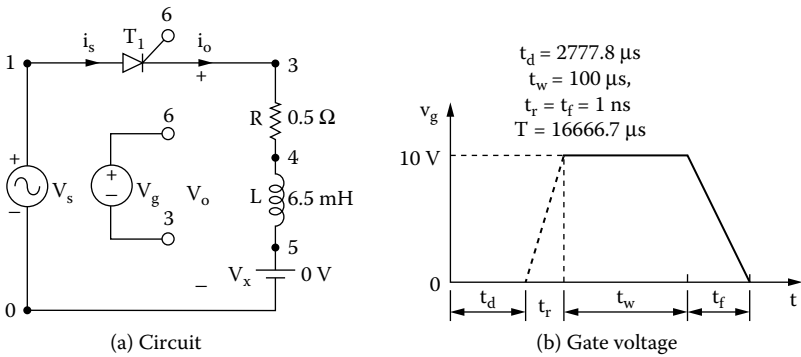


FIGURE 11.4 Single-phase half-wave controlled rectifier for PSpice simulation. (a) Circuit, (b) gate voltage.

**EXAMPLE 11.1 FINDING THE PERFORMANCE OF A SINGLE-PHASE HALF-WAVE CONTROLLED RECTIFIER**

A single-phase half-wave rectifier is shown in Figure 11.4(a). The input has a peak voltage of 169.7 V, 60 Hz. The load inductance  $L$  is 6.5 mH, and the load resistance  $R$  is 0.5  $\Omega$ . The delay angle is  $\alpha = 60^\circ$ . The gate voltage is shown in Figure 11.4(b). Use PSpice to (a) plot the instantaneous output voltage  $v_o$  and the load current  $i_o$  and (b) calculate the Fourier coefficients of the input current  $i_s$  and the input power factor  $PF$ .

**SOLUTION**

The peak supply voltage  $V_m = 169.7$  V. For  $\alpha = 60^\circ$ , time delay  $t_1 = (60/360) \times (1000/60 \text{ Hz}) \times 1000 = 2777.78 \mu\text{sec}$ . The PSpice schematic with an SCR is shown in Figure 11.5. The model name of the SCR 2N1595 is changed to SCRMOD, the subcircuit definition of which is listed in Section 11.2. Varying the delay cycle can vary the output voltage. The supply frequency {FREQ} and the duty cycle {DELAY\_ANGLE} are defined as variables. The listing of the circuit file is as follows:

### Example 11.1 Single-phase half-wave controlled rectifier

```

SOURCE  ■ VS 1 0 SIN (0169.7V60HZ)
        .PARAM Freq = 60Hz Delay_Angle = 60
        Vg 6 3 PULSE (0 1 {{Delay_Angle}}/{{360*{Freq}}}) 1ns 1ns
        100us {1/{Freq}})
CIRCUIT  ■■ R 3 4 0.5
        L 4 5 6.5MH
        VX 5 0 DC 0V ; Voltage source to measure the load current
        * Subcircuit call for thyristor model:
        XT1 1 6 3 SCRMOD ; Thyristor T1
        * Subcircuit SCR, which is missing, must be inserted.
ANALYSIS  ■■■ .TRAN 1US 50.0MS 33.33MS ; Transient analysis
        .PROBE ; Graphics post-processor
        .OPTIONS ABSTOL = 1.0N RELTOL = 1.0M VNTOL = 1.0M
        ITL5 = 10000 ; Convergence
        .FOUR 60HZI (VX) ; Fourier analysis
        .END

```

Note the following

- The PSpice plots of the instantaneous output voltage  $V(3)$  and the load current  $I(VX)$  are shown in [Figure 11.6](#). The thyristor  $T_1$  turns off when its current falls to zero, but not when the input voltage becomes zero.
- To find the input power factor, we need to find the Fourier series of the input current, which is the same as the current through source  $VX$ .

### FOURIER COMPONENTS OF TRANSIENT RESPONSE I(VX)

DC COMPONENT = 2.912470E+01

Harmonic No	Frequency (Hz)	Fourier Component	Normalized Component	Phase (Deg)	Normalized Phase (Deg)
1	6.000E+01	4.266E+01	1.000E+00	-7.433E+01	0.000E+00
2	1.200E+02	1.315E+01	3.082E-01	1.200E+02	1.943E+02
3	1.800E+02	2.897E+00	6.792E-02	1.448E+02	2.191E+02
4	2.400E+02	1.845E+00	4.325E-02	-2.775E+01	4.657E+01
5	3.000E+02	1.510E+00	3.540E-02	-3.585E+00	7.074E+01
6	3.600E+02	3.159E-01	7.406E-03	1.761E+02	2.504E+02
7	4.200E+02	8.563E-01	2.007E-02	-1.511E+02	-7.681E+01
8	4.800E+02	1.373E-01	3.218E-03	-1.137E+02	-3.936E+01
9	5.400E+02	4.678E-01	1.097E-02	6.119E+01	1.355E+02

TOTAL HARMONIC DISTORTION = 3.214001E+01 PERCENT

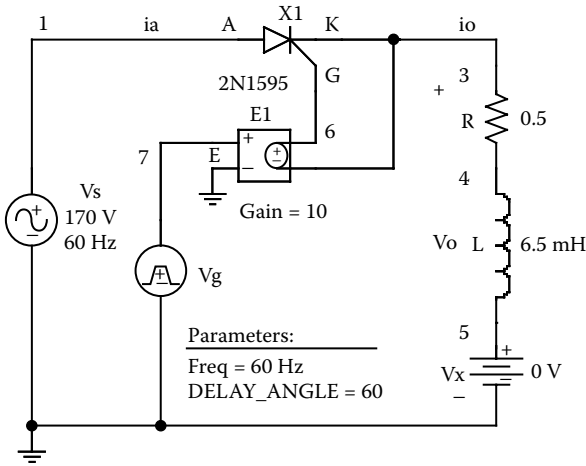


FIGURE 11.5 PSpice schematic for Example 11.1.

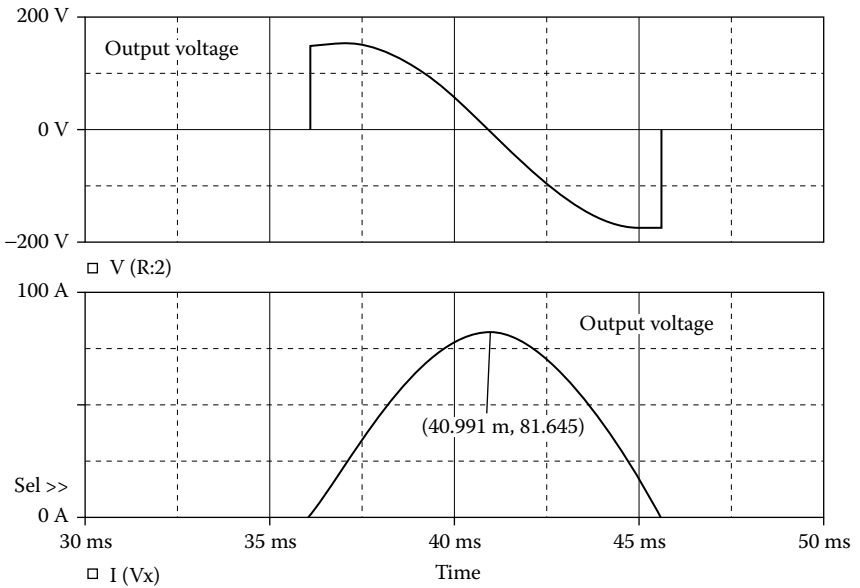


FIGURE 11.6 Plots for Example 11.1 for delay angle  $\alpha = 60^\circ$ .

DC input current  $I_{in(DC)} = 29.12 \text{ A}$

Rms fundamental input current  $I_{1(rms)} = 42.66/\sqrt{2} = 30.17 \text{ A}$

Total harmonic distortion of input current  $THD = 32.14\% = 0.3214$

Rms harmonic current  $I_{h(rms)} = I_{1(rms)} \times THD = 30.17 \times 0.3214 = 9.69$

$$\begin{aligned} \text{Rms input current, } I_s &= \left[ I_{in(DC)}^2 + I_{l(rms)}^2 + I_{h(rms)}^2 \right]^{1/2} \\ &= (29.12^2 + 30.17^2 + 9.69^2)^{1/2} = 43.4 \text{ A} \end{aligned}$$

Displacement angle,  $\phi_1 = -74.33^\circ$

Displacement factor,  $DF = \cos \phi_1 = \cos(-74.33) = 0.27$  (lagging)

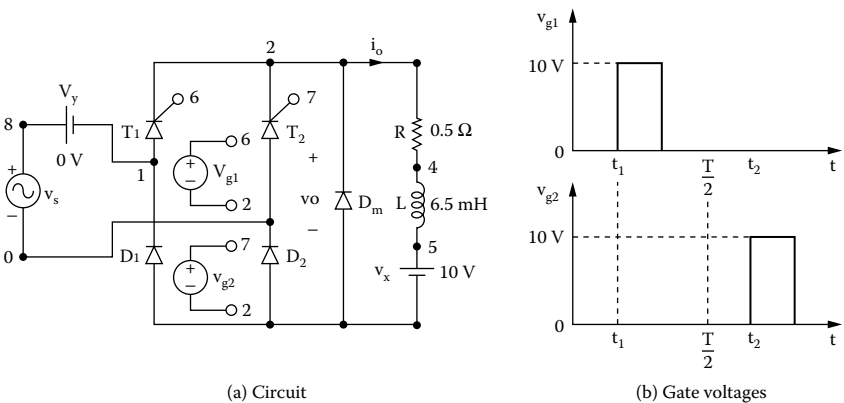
The input power factor is

$$PF = \frac{I_{l(rms)}}{I_s} \cos \phi_1 = \frac{30.17}{43.4} \times 0.27 = 0.1877 \text{ (lagging)}$$

*Note:* For a .FOUR command, TSTART and TSTOP values should be a multiple of the period of input voltage (e.g., for 60 Hz, a multiple of 16.667 msec). The Fourier coefficients will vary slightly with TMAX, because it sets the number of samples in a period.

**EXAMPLE 11.2 FINDING THE PERFORMANCE OF A SINGLE-PHASE SEMICONVERTER**

A single-phase semiconverter is shown in Figure 11.7(a). The input voltage has a peak of 169.7 V, 60 Hz. The load inductance  $L$  is 6.5 mH, and the load resistance  $R$  is 0.5  $\Omega$ . The load battery voltage is  $V_x = 10$  V. The delay angle is  $\alpha = 60^\circ$ . The gate voltages are shown in Figure 11.7(b). Use PSpice to (a) plot the instantaneous output voltage, the input current  $i_s$ , and the load current  $i_o$  and (b) calculate the Fourier coefficients of the input current  $i_s$  and the input power factor PF.



**FIGURE 11.7** Single-phase semiconverter for PSpice simulation. (a) Circuit, (b) gate voltages.

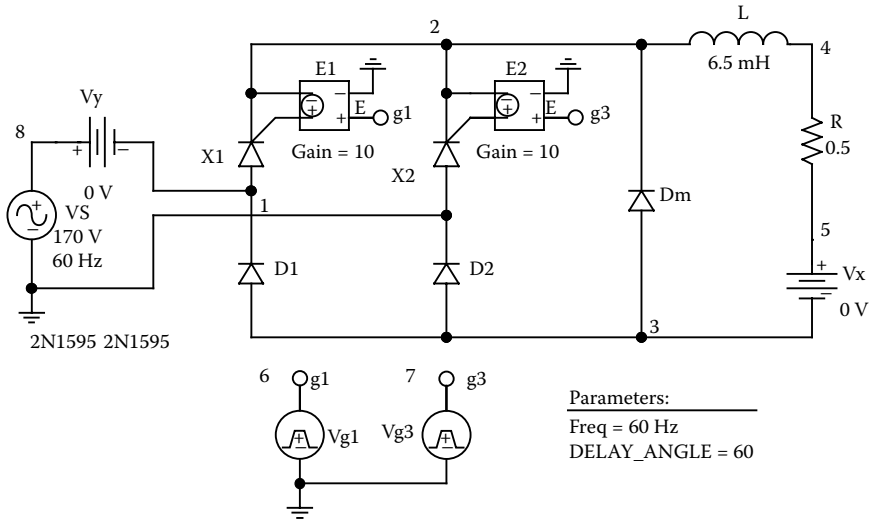


FIGURE 11.8 PSpice schematic for Example 11.2.

**SOLUTION**

The peak supply voltage  $V_m = 169.7$  V. For  $\alpha = 60^\circ$ ,

$$\text{time delay } t_1 = \frac{60}{360} \times \frac{1000}{60 \text{ Hz}} \times 1000 = 2777.78 \mu\text{sec}$$

$$\text{time delay } t_2 = \frac{240}{360} \times \frac{1000}{60 \text{ Hz}} \times 1000 = 11,111.1 \mu\text{sec}$$

The PSpice schematic with SCRs is shown in Figure 11.8. The model name of the SCR 2N1595 is changed to SCRMOD, whose subcircuit definition is listed in Section 11.2. Varying the delay cycle can vary the output voltage. The supply frequency {FREQ} and the duty cycle {DELAY\_ANGLE} are defined as variables. The model parameters for the freewheeling diode are as follows:

```
.MODEL DMD D(IS=2.22E-15 BV=1200V CJO=0PF TT=0US)
for BJTs
```

The listing of the circuit file is as follows:

**Example 11.2 Single-phase semiconverter**

```
SOURCE ■ VS 8 0 SIN(0169.7V60HZ)
.PARAM DELAY_ANGLE=60 FREQ=60HZ
Vg1 6 2 PULSE (0 1 {{Delay_Angle}}/{360*{FREQ}}) 1ns 1ns
100us {1/{FREQ}})
Vg3 7 2 PULSE (0 1 {{Delay_Angle}}+180)/{360*{FREQ}}) 1ns
1ns 100us {1/{FREQ}})
```

```

CIRCUIT ■■ R 2 4 0.5
              L 4 5 6.5MH
              VX 5 3 DC 10V ; Load battery voltage
              VY 8 1 DC 0V ; Voltage source to supply current
              D1 3 1 DMOD
              D2 3 0 DMOD
              DM 3 2 DMOD
              .MODEL DMOD D(IS = 2.2E-15 BV = 1200V TT = 0 CJO = 0)
                                   ; Diode model parameters
              * Subcircuit calls for thyristor model:
              XT1 1 6 2 SCRMOD ; Thyristor T1
              XT2 0 7 2 SCRMOD ; Thyristor T2
              * Subcircuit SCR, which is missing, must be inserted.
ANALYSIS ■■■ .TRAN 1US 50.0MS 33.33MS ; Transient analysis
                .PROBE ; Graphics post-processor
                .OPTIONS ABSTOL = 1.00N RELTOL = 1.0M VNTOL = 1.0M
                ITL5 = 10000 ; Convergence
                .FOUR 60HZ I(VY)
                .END

```

Note the following:

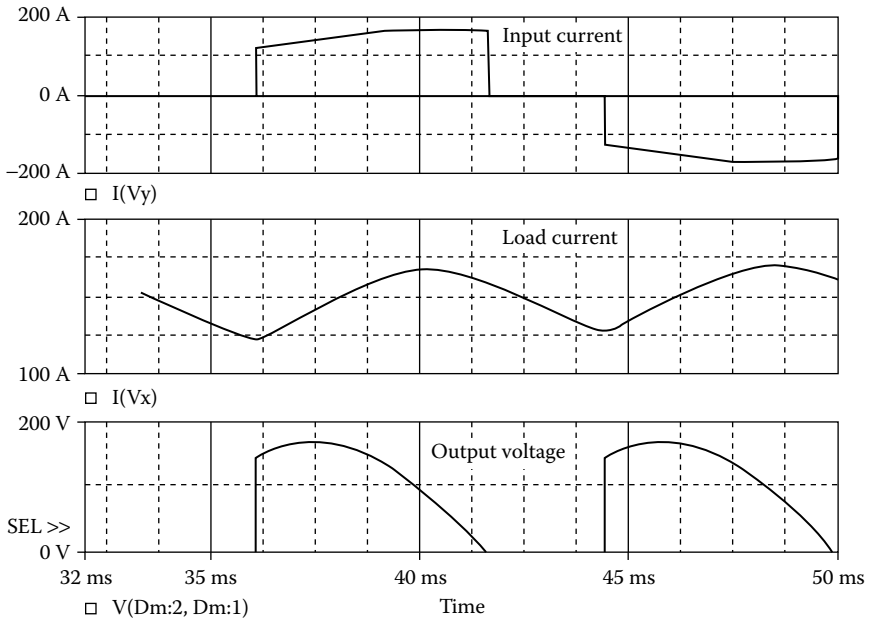
- The PSpice plots of the instantaneous output voltage  $V(2, 3)$ , the input current  $I(VY)$ , and the load current  $I(VX)$  are shown in [Figure 11.9](#). The load current is continuous as expected, and the effects of load current ripples can be noticed on the input current.
- To find the input power factor, we need to find the Fourier series of the input current, which is the same as the current through source  $VY$ .

## FOURIER COMPONENTS OF TRANSIENT RESPONSE $I(VY)$

DC COMPONENT = 4.587839E+00

Harmonic No	Frequency (Hz)	Fourier Component	Normalized Component	Phase (Deg)	Normalized Phase (Deg)
1	6.000E+01	1.436E+02	1.000E+00	-2.960E+01	0.000E+00
2	1.200E+02	1.144E+01	7.966E-02	1.008E+02	1.303E+02
3	1.800E+02	1.730E+01	1.204E-01	7.189E+01	1.015E+02
4	2.400E+02	1.035E+01	7.204E-02	1.200E+02	1.496E+02
5	3.000E+02	2.854E+01	1.987E-01	4.806E+01	7.766E+01
6	3.600E+02	1.037E+01	7.218E-02	1.353E+02	1.649E+02
7	4.200E+02	9.400E+00	6.545E-02	-7.113E+00	2.249E+01
8	4.800E+02	9.306E+00	6.480E-02	1.495E+02	1.791E+02
9	5.400E+02	7.692E+00	5.356E-02	1.414E+02	1.710E+02

TOTAL HARMONIC DISTORTION = 2.865256E+01 PERCENT



**FIGURE 11.9** Plots for Example 11.2.

Total harmonic distortion of input current  $THD = 28.65\% = 0.2865$   
 Displacement angle  $\phi_1 = -29.6^\circ$   
 Displacement factor  $DF = \cos \phi_1 = \cos(-29.6) = 0.87$  (lagging)

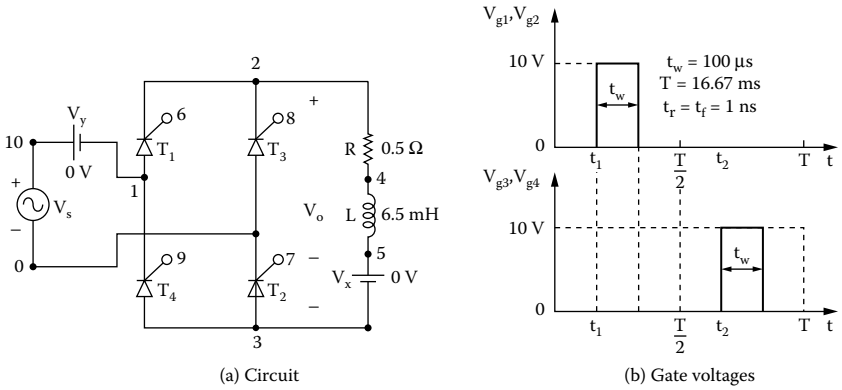
From Equation 7.3, the input power factor:

$$PF = \frac{1}{(1 + THD^2)^{1/2}} \cos \phi_1 = \frac{1}{(1 + 0.2865^2)^{1/2}} \times 0.87 = 0.836 \text{ (lagging)}$$

*Note:* The freewheeling diode  $D_m$  reduces the ripple content of the load current, thereby improving the input power factor of the converter.

**EXAMPLE 11.3 FINDING THE PERFORMANCE OF A SINGLE-PHASE FULL CONVERTER**

A single-phase full converter is shown in Figure 11.10(a). The input voltage has a peak of 169.7 V, 60 Hz. The load inductance  $L$  is 6.5 mH, and the load resistance  $R$  is 0.5  $\Omega$ . The load battery voltage is  $V_x = 10$  V. The delay angle is  $\alpha = 60^\circ$ . The gate voltages are shown in Figure 11.10(b). Use PSpice to (a) plot the instantaneous output voltage  $v_o$ , the input current  $i_s$ , and the load current  $i_o$  and (b) calculate the Fourier coefficients of the input current  $i_s$  and the input power factor PF.



**FIGURE 11.10** Single-phase full converter for PSpice simulation. (a) Circuit, (b) gate voltages.

**SOLUTION**

The peak supply voltage  $V_m = 169.7$  V. For  $\alpha_1 = 60^\circ$ ,

$$\text{time delay } t_1 = \frac{60}{360} \times \frac{1000}{60 \text{ Hz}} \times 1000 = 2777.78 \mu\text{s}$$

$$\text{time delay } t_2 = \frac{240}{360} \times \frac{1000}{60 \text{ Hz}} \times 1000 = 11,111.1 \mu\text{s}$$

The PSpice schematic with SCRs is shown in [Figure 11.11](#). The model name of the SCR 2N1595 is changed to SCRMOD whose subcircuit definition is listed in Section 11.2. Varying the delay cycle can vary the output voltage. The supply frequency {FREQ} and the duty cycle {DELAY\_ANGLE} are defined as variables. The model parameters for the freewheeling diode are as follows:

```
.MODEL DMD D(IS=2.22E-15 BV=1200V CJO=0PF TT=0US)
for Diodes
```

The listing of the circuit file is as follows:

**Example 11.3 Single-phase full-bridge converter**

```
SOURCE ■ VS 10 0 SIN(0169.7V60HZ)
.PARAM DELAY_ANGLE=60 FREQ=60Hz
Vg1 6 2 PULSE (0 1 {{Delay_Angle}}/{360*{FREQ}}) 1ns 1ns
100us {1/{FREQ}})
Vg2 7 0 PULSE (0 1 {{Delay_Angle}}/{360*{FREQ}}) 1ns 1ns
100us {1/{FREQ}} )
```

```
Vg3 8 2 PULSE (0 1 {{{Delay_Angle}+180}}/{360*{Freq}}) 1ns
1ns 100us {1/{Freq}})
Vg4 9 1 PULSE (0 1 {{{Delay_Angle}+180}}/{360*{Freq}}) 1ns
1ns 100us {1/{Freq}})
```

```
CIRCUIT ■■ R 2 4 0.5
L 4 5 6.5MH
VX 5 3 DC 10V ; Load battery voltage
VY 10 1 DC 0V ; Voltage source to measure supply current
*Subcircuit calls for thyristor model:
XT1 1 6 2 SCRMOD ; Thyristor T1
XT3 0 8 2 SCRMOD ; Thyristor T2
XT2 3 7 0 SCRMOD ; Thyristor T3
XT4 3 9 1 SCRMOD ; Thyristor T4
*Subcircuit SCR, which is missing, must be inserted
ANALYSIS ■■■ .TRAN 1US 50MS 33.33MS ; Transient analysis
.PROBE ; Graphics post-processor
.OPTIONS ABSTOL = 1.00N RELTOL = 1.0M VNTOL = 0.01
ITL5 = 20000
.FOUR 60HZ I(VY)
.END
```

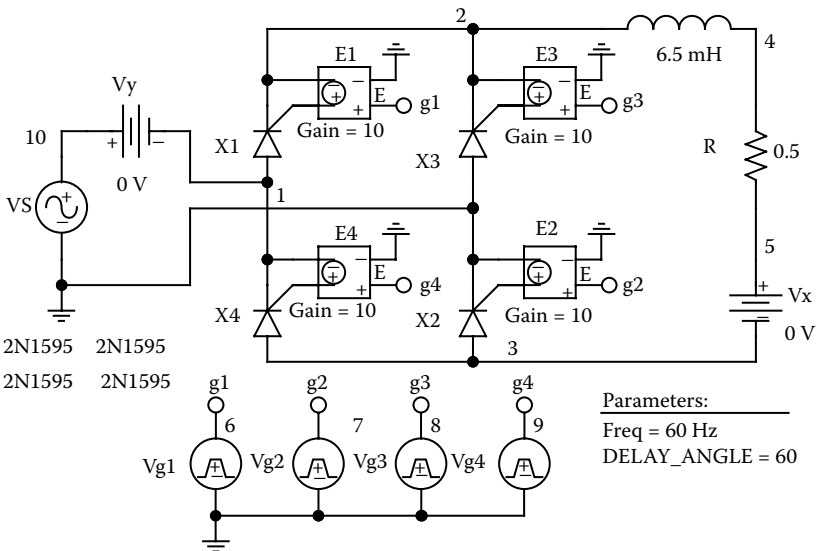


FIGURE 11.11 PSpice schematic for Example 11.3.

Note the following:

- The PSpice plots of the instantaneous output voltage  $V(2, 3)$ , the input current  $I(VY)$ , and the load current  $I(VX)$  are shown in [Figure 11.12](#). The instantaneous output voltage can be negative, but the load current is always positive.
- To find the input power factor, we need to find the Fourier series of the current through the voltage source  $VY$ .

---

## FOURIER COMPONENTS OF TRANSIENT RESPONSE I(VY)

DC COMPONENT = 1.200052E-02

Harmonic No	Frequency (Hz)	Fourier Component	Normalized Component	Phase (Deg)	Normalized Phase (Deg)
1	6.000E+01	1.113E+02	1.000E+00	-6.211E+01	0.000E+00
2	1.200E+02	8.525E-01	7.662E-03	2.244E+01	8.456E+01
3	1.800E+02	1.633E+01	1.468E-01	-1.744E+02	-1.123E+02
4	2.400E+02	3.016E-01	2.711E-03	-6.781E+01	-5.696E+00
5	3.000E+02	1.007E+01	9.046E-02	6.171E+01	1.238E+02
6	3.600E+02	2.470E-01	2.220E-03	9.033E+01	1.524E+02
7	4.200E+02	7.179E+00	6.452E-02	-5.831E+01	3.806E+00
8	4.800E+02	3.580E-01	3.218E-03	-3.425E+00	5.869E+01
9	5.400E+02	5.454E+00	4.902E-02	1.796E+02	2.417E+02

TOTAL HARMONIC DISTORTION = 1.907363E+01 PERCENT

Total harmonic distortion of input current  $THD = 19.07\% = 0.1907$

Displacement angle  $\phi_1 = -62.1^\circ$

Displacement factor  $DF = \cos \phi_1 = \cos(-62.1) = 0.468$  (lagging)

From Equation 7.3, the input power factor is

$$PF = \frac{1}{(1 + THD^2)^{1/2}} \cos \phi_1 = \frac{1}{(1 + 0.1907^2)^{1/2}} \times 0.468 = 0.46 \text{ (lagging)}$$

*Note:* For an inductive load, the output voltage can be either positive or negative. The input power factor, however, is lower than that of the semiconverter at the same delay angle  $\alpha = 60^\circ$ .

### EXAMPLE 11.4 FINDING THE PERFORMANCE OF A THREE-PHASE HALF-WAVE CONVERTER

A three-phase half-wave converter is shown in [Figure 11.13\(a\)](#). The input voltage per phase has a peak of 169.7 V, 50 Hz. The load inductance  $L$  is 6.5 mH, and the load resistance  $R$  is 0.5  $\Omega$ . The load battery voltage is  $V_x = 10$  V. The delay angle is  $\alpha = 90^\circ$ . The gate voltages are shown in [Figure 11.13\(b\)](#). Use PSpice to (a) plot the instantaneous output voltage  $v_o$  and the load current  $i_o$  and (b) calculate the Fourier coefficient of the input current  $i_s$  and the input power factor  $PF$ .

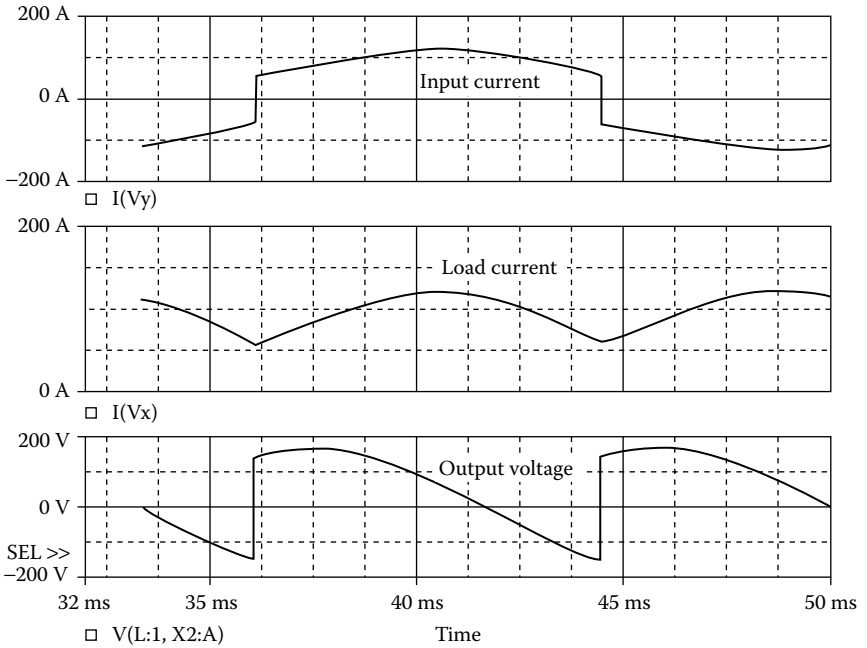


FIGURE 11.12 Plots for Example 11.3 for delay angle  $\alpha = 60^\circ$ .

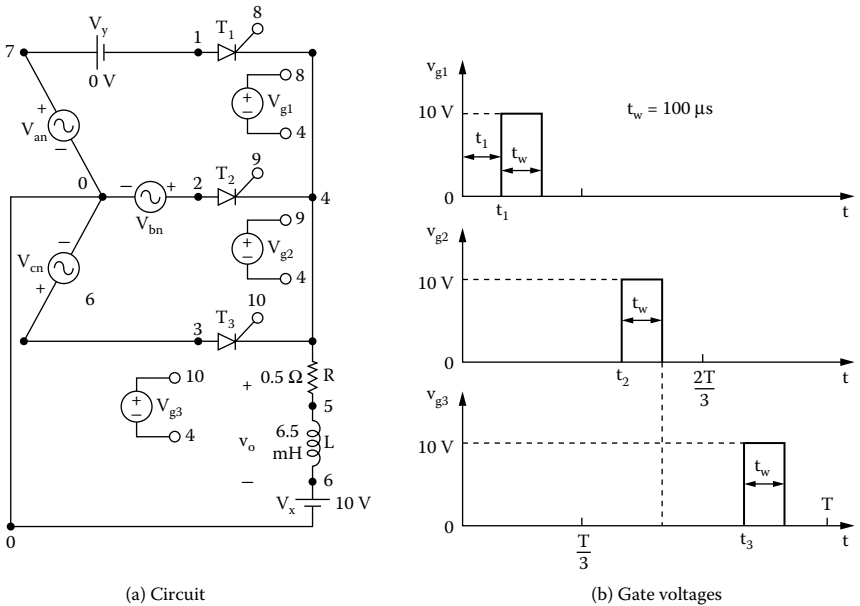


FIGURE 11.13 Three-phase half-wave converter for PSpice simulation. (a) Circuit, (b) gate voltages.

**SOLUTION**

The peak supply voltage  $V_m = \sqrt{2} V_s = \sqrt{2} \times 120 = 169.7 \text{ V}$ . For  $\alpha = 90^\circ$ ,

$$\text{time delay } t_1 = \frac{90}{360} \times \frac{1000}{60 \text{ Hz}} \times 1000 = 4166.7 \text{ } \mu\text{sec}$$

$$\text{time delay } t_2 = \frac{210}{360} \times \frac{1000}{60 \text{ Hz}} \times 1000 = 9722.2 \text{ } \mu\text{sec}$$

$$\text{time delay } t_3 = \frac{330}{360} \times \frac{1000}{60 \text{ Hz}} \times 1000 = 15,277.8 \text{ } \mu\text{sec}$$

The PSpice schematic with SCRs is shown in [Figure 11.14](#). The model name of the SCR 2N1595 is changed to SCRMOD whose subcircuit definition is listed in Section 11.2. Varying the delay cycle can vary the output voltage. The supply frequency {FREQ} and the duty cycle {DELAY\_ANGLE} are defined as variables. The model parameters for the freewheeling diode are as follows:

```
.MODEL DMD D(IS=2.22E-15 BV=1200V CJO=0PF TT=0US) for
BJTs
```

The listing of the circuit file is as follows:

**Example 11.4 Three-phase half-wave converter**

```
SOURCE   ■ Van 7  0 SIN(0 169.7V 60HZ)
           Vbn 2  0 SIN(0 169.7V 60HZ 00-120DEG)
           Vcn 3  0 SIN(0 169.7V 60HZ 00-240DEG)
           Vg1 8  4 PULSE (0V 10V 4166.7US 1NS 1NS 100US 16666.7US)
           Vg2 9  4 PULSE (0V 10V 9722.2US 1NS 1NS 100US 16666.7US)
           Vg3 10 4 PULSE (0V 10V 15277.8US 1NS 1NS 100US 16666.7US)
           .PARAM Freq=60Hz Delay_Angle=90
           Vg1 8  4 PULSE (0 1 {{Delay_Angle}}/{360*{Freq}}) 1ns 1ns
           100us {1/{Freq}})
           Vg2 9  4 PULSE (0 1 {{Delay_Angle}+120}}/{360*{Freq}})
           1ns 1ns 100us {1/{Freq}})
           Vg3 10 4 PULSE (0 1 {{Delay_Angle}+240}}/{360*{Freq}})
           1ns 1ns 100us {1/{Freq}})
CIRCUIT  ■■ R  4 5 0.5
           L  5 6 6.5MH
           VX 6 0 DC 10V ; Load battery voltage
           VY 7 1 DC 0V ; Voltage source to measure supply
           current
           * Subcircuit calls for thyristor model:
           XT1 1 8 4 SCRDM ; Thyristor T1
```

```

XT2 2 9 4 SCR D      ; Thyristor T3
XT3 3 10 4 SCR D     ; Thyristor T2

```

\* Subcircuit SCR D, which is missing, must be inserted.

```

ANALYSIS ■■■ .TRAN 100US 50MS 33.33MS ; Transient analysis
               .PROBE                    ; Graphics post-processor
               .OPTIONS ABSTOL = 1.00N RELTOL = 1.0M VNTOL = 1.0M
               ITL5 = 20000              ; Convergence
               .FOUR 60HZ I(VY)
               .END

```

Note the following:

- The PSpice plots of the instantaneous output voltage V(4) and the load current I(VX) are shown in [Figure 11.15](#). The average load current is greater than that of a single-phase converter.
- The Fourier series of the current through voltage source VY is

#### FOURIER COMPONENTS OF TRANSIENT RESPONSE I(VY)

DC COMPONENT = 4.048497E+01

Harmonic No	Frequency (Hz)	Fourier Component	Normalized Component	Phase (Deg)	Normalized Phase (Deg)
1	6.000E+01	6.793E+01	1.000E+00	-6.001E+01	0.000E+00
2	1.200E+02	3.650E+01	5.373E-01	1.499E+02	2.099E+02
3	1.800E+02	4.317E+00	6.354E-02	-2.866E+00	5.715E+01
4	2.400E+02	1.315E+01	1.936E-01	3.128E+01	9.129E+01
5	3.000E+02	1.216E+01	1.790E-01	-1.188E+02	-5.882E+01
6	3.600E+02	1.108E+00	1.631E-02	9.453E+01	1.545E+02
7	4.200E+02	7.661E+00	1.128E-01	1.206E+02	1.806E+02
8	4.800E+02	7.409E+00	1.091E-01	-2.886E+01	3.116E+01
9	5.400E+02	5.800E-01	8.538E-03	-1.720E+02	-1.120E+02

TOTAL HARMONIC DISTORTION = 6.222461E+01 PERCENT

DC input current  $I_{in(DC)} = 40.48$  A

Rms fundamental input current  $I_{1(rms)} = 67.93/\sqrt{2} = 48.03$  A

Total harmonic distortion of input current THD = 62.22% = 0.6222

Rms harmonic current  $I_{h(rms)} = I_{1(rms)} \times \text{THD} = 48.03 \times 0.6222 = 29.88$  A

$$\begin{aligned}
 \text{Rms input current } I_s &= \left[ I_{in(DC)}^2 + I_{1(rms)}^2 + I_{h(rms)}^2 \right]^{1/2} \\
 &= (40.48^2 + 48.03^2 + 29.88^2)^{1/2} = 69.56 \text{ A}
 \end{aligned}$$

Displacement angle  $\phi_1 = -60.01^\circ$

Displacement factor  $DF = \cos \phi_1 = \cos(-60.01) = 0.5$  (lagging)

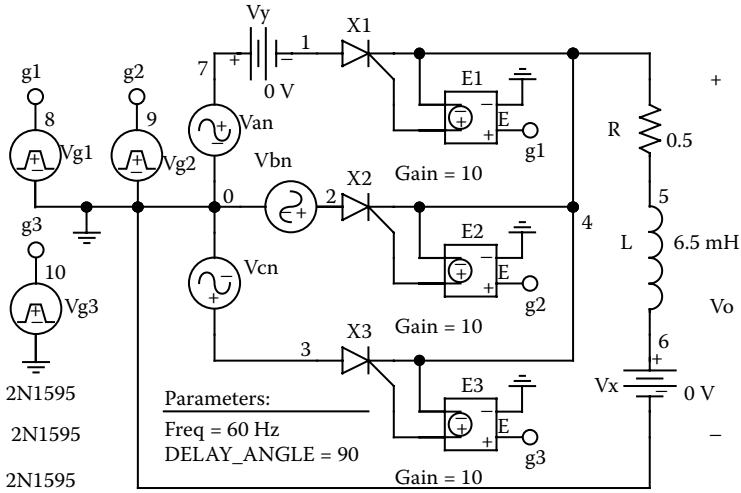


FIGURE 11.14 PSpice schematic for Example 11.4.

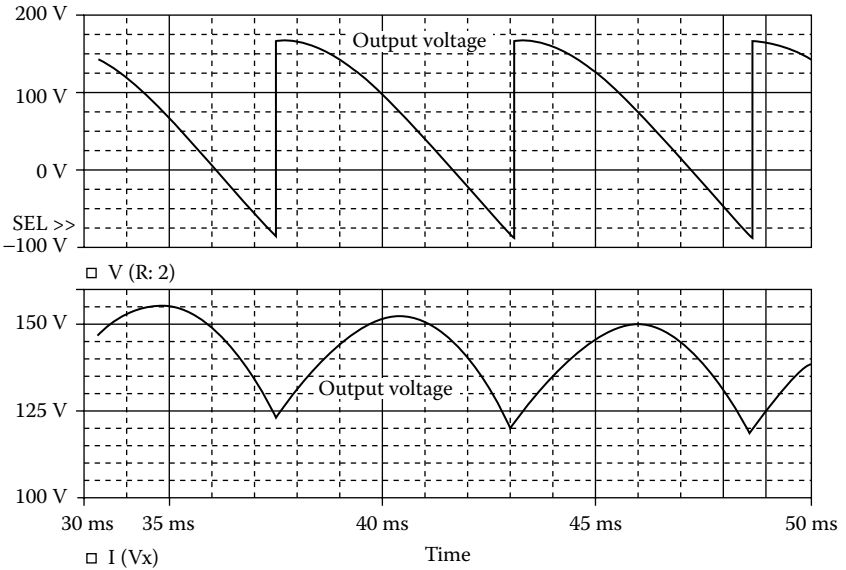


FIGURE 11.15 Plots for Example 11.4 for delay angle  $\alpha = 90^\circ$ .

Thus the input power factor is

$$PF = \frac{I_{l(ms)}}{I_s} \cos \phi_1 = \frac{48.03}{69.56} \times 0.5 = 0.3452 \text{ (lagging)}$$

*Note:* The input current from each phase contains a DC component, thereby causing a low power factor and DC saturation problem for the input-side transformer.

### EXAMPLE 11.5 FINDING THE PERFORMANCE OF A THREE-PHASE SEMICONVERTER

A three-phase semiconverter is shown in Figure 11.16(a). The input voltage per phase has a peak of 169.7 V, 60 Hz. The load inductance  $L$  is 6.5 mH, and the load resistance  $R$  is 0.5  $\Omega$ . The load battery voltage is  $V_x = 10$  V. The delay angle is  $\alpha = 90^\circ$ . The gate voltage are shown in Figure 11.16(b). Use PSpice to (a) plot the instantaneous output voltage  $v_o$ , the load current  $i_o$ , and the input current  $i_s$  and (b) calculate the Fourier coefficients of the input current  $i_s$  and the input power factor PF.

#### SOLUTION

The peak supply voltage  $V_m = 169.7$  V. For  $\alpha = 90^\circ$ ,

$$\text{time delay } t_1 = \frac{90}{360} \times \frac{1000}{60 \text{ Hz}} \times 1000 = 4166.7 \text{ } \mu\text{sec}$$

$$\text{time delay } t_2 = \frac{210}{360} \times \frac{1000}{60 \text{ Hz}} \times 1000 = 9722.2 \text{ } \mu\text{sec}$$

$$\text{time delay } t_3 = \frac{330}{360} \times \frac{1000}{60 \text{ Hz}} \times 1000 = 15,277.8 \text{ } \mu\text{sec}$$

The PSpice schematic with SCRs is shown in Figure 11.17. The model name of the SCR 2N1595 is changed to SCRMOD, whose subcircuit definition is listed in Section 11.2. Varying the delay cycle can vary the output voltage. The supply frequency {FREQ} and the duty cycle {DELAY\_ANGLE} are defined as variables. The model parameters for the freewheeling diode are as follows:

```
.MODEL DMD D(IS=2.22E-15 BV=1200V CJO=0PF TT=0US) for Diodes
```

The listing of the circuit file is as follows:

---

### Example 11.5 Three-phase semiconverter

```
SOURCE ■ Van 11 0 SIN(0 169.7V 60HZ)
        Vbn 2 0 SIN(0 169.7C 60HZ00-120DEG)
        Vcn 3 0 SIN(0 169.7C 60HZ00-240DEG)
        .PARAM Freq=60Hz Delay_Angle=90
        Vg1 8 4 PULSE (0 1 {{Delay_Angle}}/{360*{Freq}}) 1ns 1ns
            100us {1/{Freq}})
        Vg2 9 4 PULSE (0 1 {{Delay_Angle}+120}}/{360*{Freq}})
            1ns 1ns 100us {1/{Freq}})
        Vg3 10 4 PULSE (0 1 {{Delay_Angle}+240}}/{360*{Freq}})
            1ns 1ns 100us {1/{Freq}})
```

```

CIRCUIT ■■ R 4 6 0.5
              L 6 7 6.5MH
              VX 7 5 DC 10V ; Load battery voltage
              VY 11 1 DC 0V ; Voltage source to measure supply
              current
              D1 5 1 DMOD
              D2 5 2 DMOD
              D3 5 3 DMOD
              DM 5 4 DMOD
              .MODEL DMOD D(IS = 2.2E - 15 BV = 1200V TT = 0 CJO =
              1PF) ; Diode model parameters
              *Subcircuit calls for thyristor model:
              XT1 1 8 4 SCRMOD ; Thyristor T1
              XT2 2 9 4 SCRMOD ; Thyristor T3
              XT3 3 10 4 SCRMOD ; Thyristor T2
              *Subcircuit SCR, which is missing, must be inserted.
ANALYSIS ■■■ .TRAN 1US 50MS 33.33MS ; Transient analysis
                .PROBE ; Graphics post-processor
                .OPTIONS ABSTOL = 100.U RELTOL = 0.01 VNTOL = 0.01
                ITL5 = 20000
                .FOUR 60HZ I(VY)
                .END

```

Note the following:

- The PSpice plots of the instantaneous output voltage  $V(4, 5)$ , the load current  $I(VX)$ , and the input current  $I(VY)$  are shown in [Figure 11.18](#). The ripple contents on the output voltage and output current are lower than those of a single-phase converter.
- The Fourier series of the input current is as follows:

---

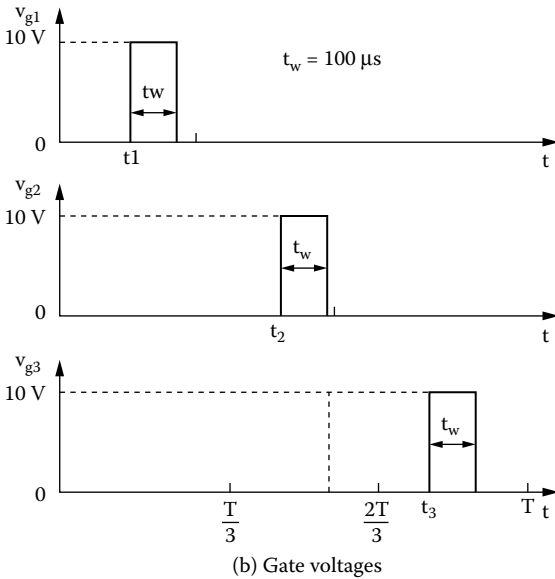
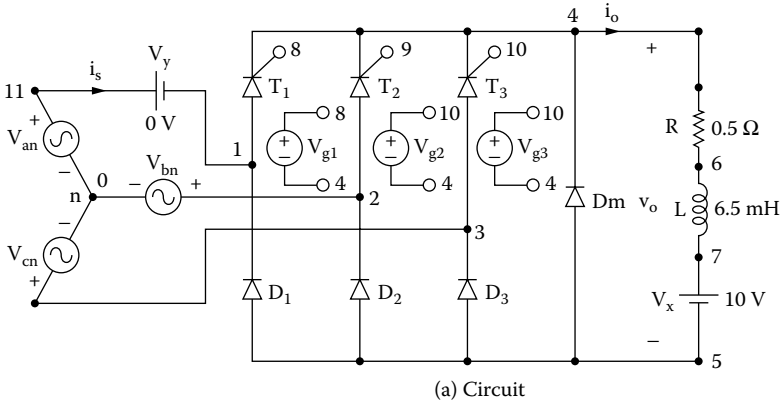
### FOURIER COMPONENTS OF TRANSIENT RESPONSE I(VY)

DC COMPONENT = 8.208448E-01

Harmonic No	Frequency (Hz)	Fourier Component	Normalized Component	Phase (Deg)	Normalized Phase (Deg)
1	6.000E+01	3.753E+02	1.000E+00	-3.022E+01	0.000E+00
2	1.200E+02	1.943E+02	5.177E-01	1.195E+02	1.498E+02
3	1.800E+02	1.153E-01	3.073E-04	8.665E+01	1.169E+02
4	2.400E+02	8.585E+01	2.287E-01	6.213E+01	9.235E+01
5	3.000E+02	7.424E+01	1.978E-01	-1.483E+02	-1.180E+02
6	3.600E+02	5.945E-02	1.584E-04	1.676E+02	1.978E+02
7	4.200E+02	4.864E+01	1.296E-01	1.519E+02	1.822E+02
8	4.800E+02	4.660E+01	1.242E-01	-5.781E+01	-2.759E+01
9	5.400E+02	4.144E-02	1.104E-04	-1.095E+02	-7.932E+01

TOTAL HARMONIC DISTORTION = 6.258354E+01 PERCENT

---



**FIGURE 11.16** Three-phase semiconverter for PSpice simulation. (a) Circuit, (b) gate voltages. For  $\alpha = 90^\circ$ .

Total harmonic distortion of input current  $THD = 62.58\% = 0.6258$

Displacement angle  $\phi_1 = -30.2^\circ$

Displacement factor  $DF = \cos \phi_1 = \cos(-30.2) = 0.864$  (lagging)

The input power factor is

$$PF = \frac{1}{(1 + THD^2)^{1/2}} \cos \phi_1 = \frac{1}{(1 + 0.6258^2)^{1/2}} \times 0.864 = 0.732 \text{ (lagging)}$$

*Note:* The freewheeling diode  $D_m$  reduces the ripple of the load current, thereby improving the input power factor of the converter.

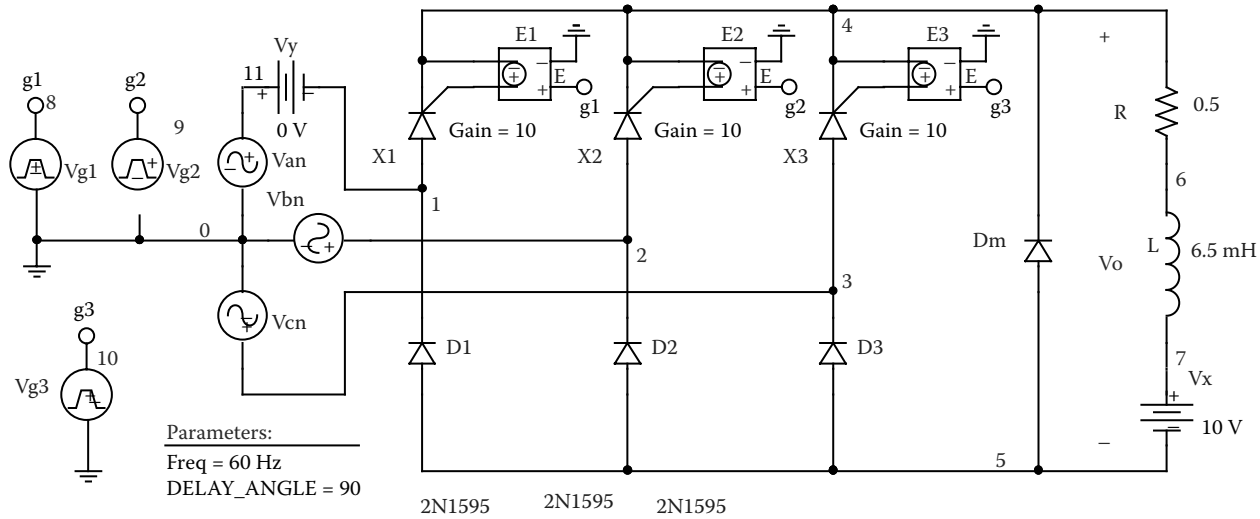
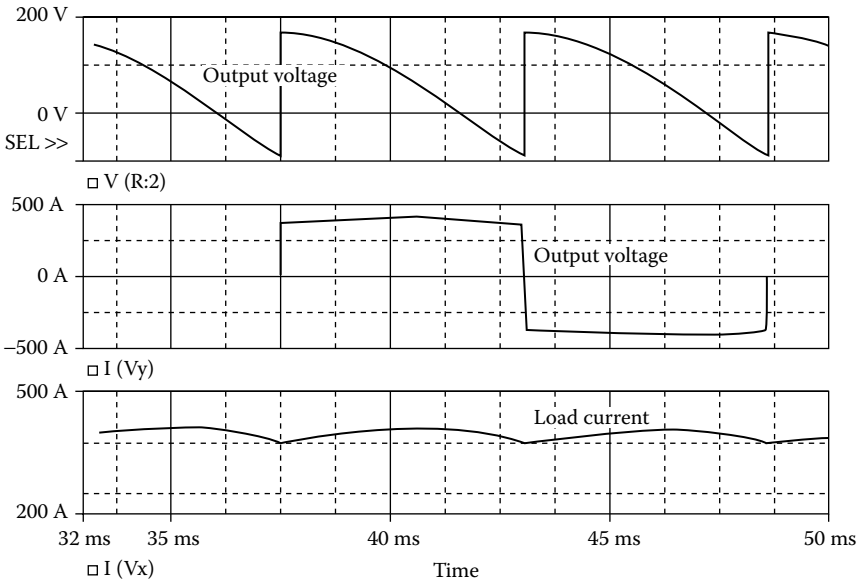


FIGURE 11.17 PSpice schematic for Example 11.5.



**FIGURE 11.18** Plots for Example 11.5 for delay angle  $\alpha = 90^\circ$ .

**EXAMPLE 11.6 FINDING THE PERFORMANCE OF A THREE-PHASE FULL-BRIDGE CONVERTER**

A three-phase full-bridge converter is shown in Figure 11.19(a). The input voltage per phase has a peak of 169.7 V, 60 Hz. The load inductance  $L$  is 6.5 mH, and the load resistance  $R$  is 0.5  $\Omega$ . The load battery voltage is  $V_x = 10$  V. The delay angle is  $\alpha = 90^\circ$ . The gate voltages are shown in Figure 11.19(b). Use PSpice to (a) plot the instantaneous output voltage  $v_o$ , the load current  $i_o$ , and the input current  $i_s$  and (b) calculate the Fourier coefficients of the input current  $i_s$  and the input power factor PF.

**SOLUTION**

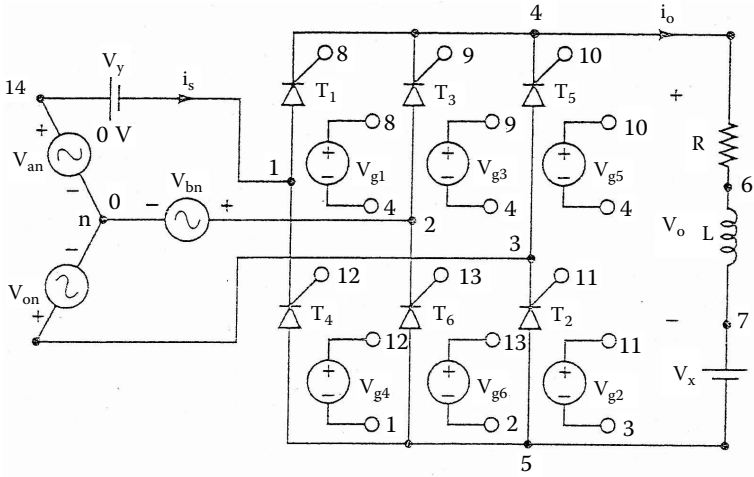
For  $\alpha = 90^\circ$ ,

$$\text{time delay } t_1 = \frac{90}{360} \times \frac{1000}{60 \text{ Hz}} \times 1000 = 4166.7 \text{ } \mu\text{sec}$$

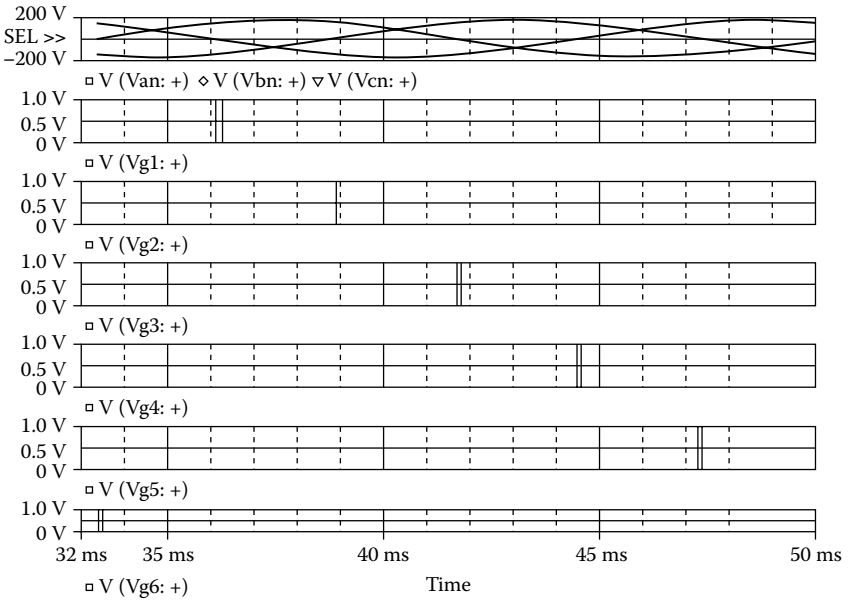
$$\text{time delay } t_3 = \frac{210}{360} \times \frac{1000}{60 \text{ Hz}} \times 1000 = 9722.2 \text{ } \mu\text{sec}$$

$$\text{time delay } t_5 = \frac{330}{360} \times \frac{1000}{60 \text{ Hz}} \times 1000 = 15,277.8 \text{ } \mu\text{sec}$$

$$\text{time delay } t_2 = \frac{150}{360} \times \frac{1000}{60 \text{ Hz}} \times 1000 = 6944.4 \text{ } \mu\text{sec}$$



(a)



(b)

**FIGURE 11.19** Three-phase full-bridge converter for PSpice simulation. (a) Circuit, (b) gate voltages. For  $\alpha = 90^\circ$ .

$$\text{time delay } t_4 = \frac{270}{360} \times \frac{1000}{60 \text{ Hz}} \times 1000 = 12,500.0 \text{ } \mu\text{sec}$$

$$\text{time delay } t_6 = \frac{30}{360} \times \frac{1000}{60 \text{ Hz}} \times 1000 = 1388.9 \text{ } \mu\text{sec}$$

The PSpice schematic with SCRs is shown in [Figure 11.20](#). The model name of the SCR 2N1595 is changed to SCRMOD, whose subcircuit definition is listed in Section 11.2. Varying the delay cycle can vary the output voltage. The supply frequency {FREQ} and the duty cycle {DELAY\_ANGLE} are defined as variables. The model parameters for the freewheeling diode are as follows:

.MODEL DMD D(IS=2.22E-15 BV=1200V CJO=0PF TT=0US)) for Diodes

The listing of the circuit file is as follows:

### Example 11.6 Three-phase full-bridge converter

```

SOURCE   ■ Van 14 0 SIN(0 169.7V 60HZ)
            Vbn  2 0 SIN(0 169.7C 60HZ00-120DEG)
            Vcn  3 0 SIN(0 169.7C 60HZ00-240DEG)
            .PARAM DELAY_ANGLE=60  FREQ=60Hz
            Vg1  8 4 PULSE (0 1 {{Delay_Angle}}/{360*{FREQ}}) 1ns 1ns
                100us {1/{FREQ}})
            Vg3  9 4 PULSE (0 1 {{Delay_Angle}}+120)/{360*{FREQ}}
                1ns 1ns 100us {1/{FREQ}})
            Vg5 10 4 PULSE (0 1 {{Delay_Angle}}+240)/{360*{FREQ}}
                1ns 1ns 100us {1/{FREQ}})
            Vg2 11 3 PULSE (0 1 {{Delay_Angle}}+60)/{360*{FREQ}}
                1ns 1ns 100us {1/{FREQ}})
            Vg4 12 1 PULSE (0 1 {{Delay_Angle}}+180)/{360*{FREQ}}
                1ns 1ns 100us {1/{FREQ}})
            Vg6 13 2 PULSE (0 1 {{Delay_Angle}}+300)/{360*{FREQ}}
                1ns 1ns 100us {1/{FREQ}})

CIRCUIT  ■■ R   4  6 0.5
                L   6  7 6.5MH
                VX  7  5 DC 10V    ; Load battery voltage
                VY 14  1 DC 0V     ; Voltage source to measure supply
                current
                *Subcircuit calls for thyristor model:
                XT1 1  8 4 SCRMOD   ; Thyristor T1
                XT3 2  9 4 SCRMOD   ; Thyristor T3
                XT5 3 10 4 SCRMOD  ; Thyristor T5
                XT2 5 11 3 SCRMOD  ; Thyristor T2
                XT4 5 12 1 SCRMOD  ; Thyristor T4
                XT6 5 13 2 SCRMOD  ; Thyristor T6
                *Subcircuit SCR, which is missing, must be inserted.

ANALYSIS ■■■ .TRAN 1US 50MS 33.33MS      ; Transient analysis
                .PROBE                      ; Graphics post-processor
                .FOUR 60HZ I(VY)
                .OPTIONS ABSTOL = 1.00N RELTOL = 0.01 VNTOL = 0.01
                ITL5 = 20000
                ;

                Convergence

                .END

```

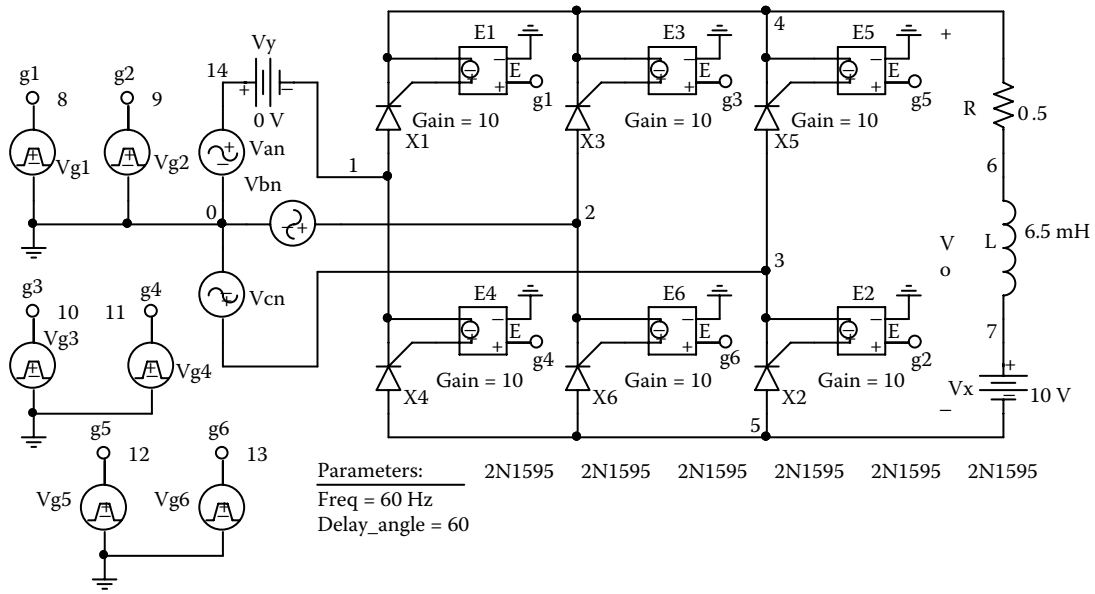


FIGURE 11.20 PSpice schematic for Example 11.6.

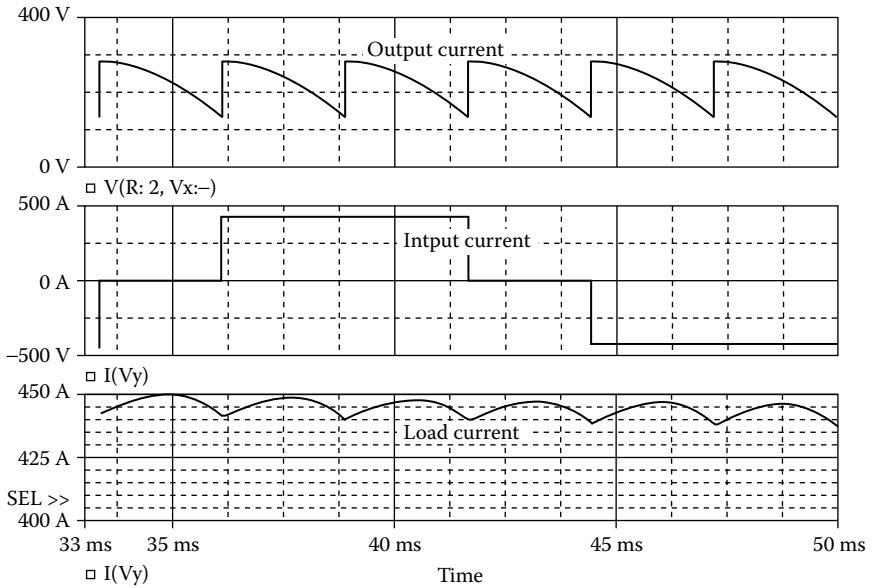


FIGURE 11.21 Plots for Example 11.6 for delay angle  $\alpha = 90^\circ$ .

Note the following:

- (a) The PSpice plots of the instantaneous output voltage  $V(4, 5)$  the load current  $I(VX)$ , and the input current  $I(VY)$  are shown in Figure 11.21. The load current has not reached the steady-state condition.
- (b) The Fourier series of the input current is as follows:

**FOURIER COMPONENTS OF TRANSIENT RESPONSE I(VY)**

DC COMPONENT = 7.862956E-01

Harmonic No	Frequency (Hz)	Fourier Component	Normalized Component	Phase (Deg)	Normalized Phase (Deg)
1	6.000E+01	2.823E+02	1.000E+00	-6.021E+01	0.000E+00
2	1.200E+02	2.387E+00	8.453E-03	-1.651E+02	-1.048E+02
3	1.800E+02	1.885E+00	6.676E-03	-1.540E+02	-9.383E+01
4	2.400E+02	1.952E+00	6.915E-03	-1.020E+02	-4.179E+01
5	3.000E+02	6.049E+01	2.143E-01	-1.211E+02	-6.088E+01
6	3.600E+02	1.836E+00	6.503E-03	-1.761E+02	-1.159E+02
7	4.200E+02	3.774E+01	1.337E-01	1.216E+02	1.818E+02
8	4.800E+02	1.473E+00	5.216E-03	-1.451E+02	-8.488E+01
9	5.400E+02	6.411E-01	2.271E-03	1.662E+02	2.264E+02

TOTAL HARMONIC DISTORTION = 2.530035E+01 PERCENT

Total harmonic distortion of input current  $\text{THD} = 25.3\% = 0.253$

Displacement angle  $\phi_1 = -60.21^\circ$

Displacement factor  $DF = \cos \phi_1 = \cos(-60.21) = 0.497$  (lagging)

The input power factor is

$$\text{PF} = \frac{1}{(1 + \text{THD}^2)^{1/2}} \cos \phi_1 = \frac{1}{(1 + 0.253^2)^{1/2}} \times 0.497 = 0.482 \quad (\text{lagging})$$

*Note:* For an inductive load, the output voltage can be either positive or negative. The input power factor is, however, lower than that of the semiconverter at the same delay angle  $\alpha = 90^\circ$ .

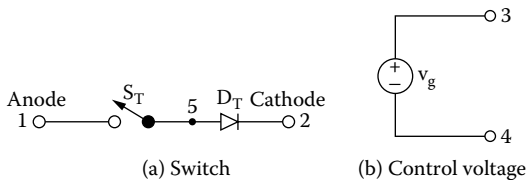
## 11.5 SWITCHED THYRISTOR DC MODEL

Forced-commutated converters are being used increasingly to improve the input power factor. These converters operate power devices as switches. The switches are turned on or off at a specified time. We do not need latching characteristics. Rather, we need to operate them as on and off switches, similar to gate turn-off (GTO) thyristors. We shall model a power device as the voltage-controlled switch shown in Figure 11.22. This model, called a *switched thyristor DC model*, is also used in Chapter 10. The subcircuit definition SSCR can be described as follows:

---

```
* Subcircuit for switched thyristor model:
.SUBCKT SSCR      1      2      3      4
*      model anode cathode +control -control
*      name          voltage  voltage
DT      5      2      DMOD          ; Switch diode
ST      1      5      3      4 SMOD          ; Switch
.MODEL DMOD D (IS = 2.2E - 15 BV = 1200V TT = 0 CJO = 0) ; Diode
model parameters
.MODEL SMOD VSWITCH (RON = 0.01 ROFF = 10E + 6 VON = 10V VOFF = 5V)
.ENDS SSCR ; Ends subcircuit definition
```

---



**FIGURE 11.22** Switched DC thyristor model.

## 11.6 GTO THYRISTOR MODEL

There are dedicated PSpice GTO models [1, 7–9]. The AC thyristor model of Figure 11.1(b) can, however, be used as a GTO. The turn-on is similar to a normal SCR. However, the turn-off gate voltage must be negative with appropriate magnitude and be capable of turning off at the maximum possible current. Therefore, the turn-off gate voltage  $v_{gn}$  must satisfy the condition

$$P_1 I_g + P_2 I_{a(\max)} \leq 0 \quad \text{or} \quad P_1 \frac{v_{gn}}{R_G} + P_2 I_{a(\max)} \leq 0$$

which gives the magnitude of  $v_{gn}$  as

$$|v_{gn}| \geq \frac{P_2 I_{a(\max)}}{P_1} R_G \quad (11.6)$$

For  $I_{T(\text{RMS})} = 110$  A,  $I_{a(\max)} = \sqrt{2} I_{T(\text{RMS})} = \sqrt{2} \times 110 = 156$  V. Using  $P_1 = 50$ ,  $P_2 = 11$ , and  $R_G = 50 \Omega$ , we get  $|v_{gn}| \geq (11 \times 156 \times 50 / 50) = 1716$  V. Thus, subcircuit model SCR must be gated with a positive pulse voltage  $v_g$  to turn on, and a negative pulse voltage  $v_{gn}$  to turn off.

## 11.7 EXAMPLE OF FORCED-COMMUTATED RECTIFIERS

The conduction angles of one or more switches can be generated by using a comparator with a reference signal  $v_r$  and a carrier signal  $v_c$  as shown in Figure 11.23(a). The pulse width  $\delta$  can be varied by varying the carrier voltage  $v_c$ . This technique, known as PWM, can be implemented in PSpice schematics as shown in Figure 11.23(b).  $V_{cr}$  is the carrier signal, either DC or a rectifier sinusoidal signal at the output or supply frequency.  $V_{ref}$  is a triangular signal at the switching frequency, and  $V_p$  is the pulse at the output or supply frequency with 50% duty cycle. The inputs to the amplifier are  $v_r$  and  $v_c$ . Its output is the conduction angle  $\delta$  during which a switch remains on.

The modulation index  $M$  is defined by

$$M = \frac{A_c}{A_r} \quad (11.7)$$

where  $A_r$  is the peak value of a reference signal  $v_r$ , and  $A_c$  is the peak value of a carrier signal  $v_c$ .

The PWM modulator can be used as a subcircuit to generate control signals for a triangular reference voltage of one or more pulses per half cycle and a DC (or sinusoidal) carrier signal. The subcircuit definition for the modulator model PWM can be described as follows:

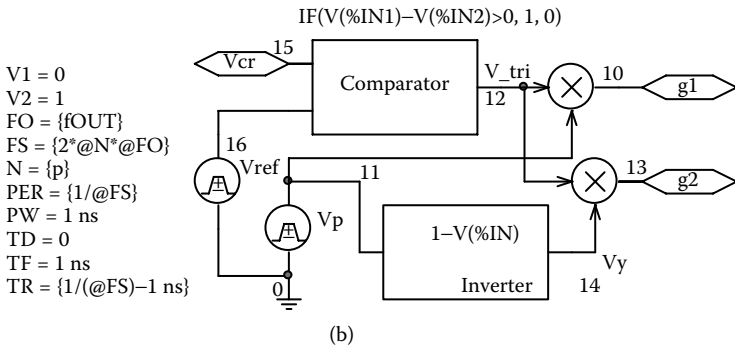
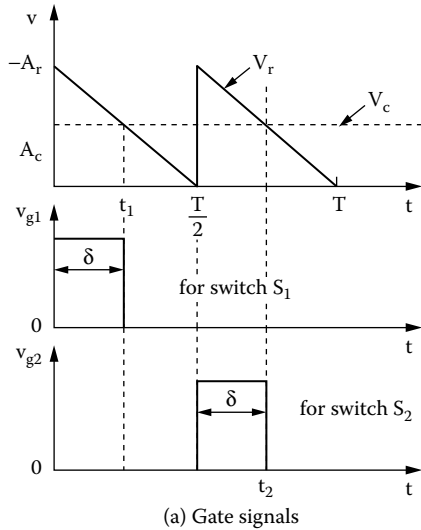
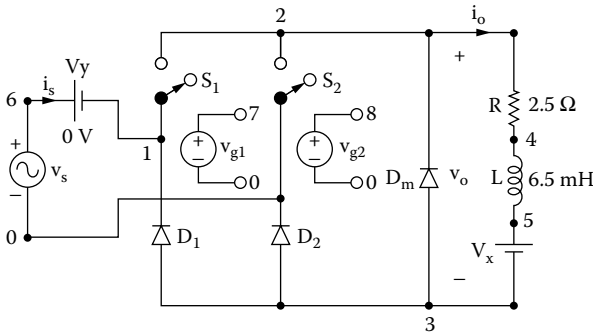


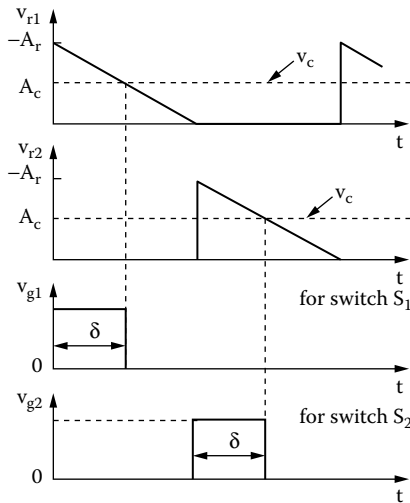
FIGURE 11.23 PWM control. (a) Gate signals, (b) PSpice comparator.

```

* Subcircuit for generating PWM control signals
.SUBCKT PWM 1 2 3 4
* model ref. carrier +g1 +g2
* name input input voltage voltage
E_ABM1 6 0 VALUE {IF(V(2)-V(1)>0, 1, 0)} ; Comparator
Vp 5 0 PULSE (0 1 0 1ns 1ns {1/(2*fout)}-2ns {1/fout}); Pulse
E_ABM2 7 0 VALUE {1-V(5)} ; Inverter
E_MULT1 3 0 VALUE {V(5)*V(6)} ; Multiplier 1
E_MULT2 4 0 VALUE {V(7)*V(6)} ; Multiplier 2
.ENDS PWM ; Ends subcircuit definition
    
```



(a) Circuit



(b) Gate voltages

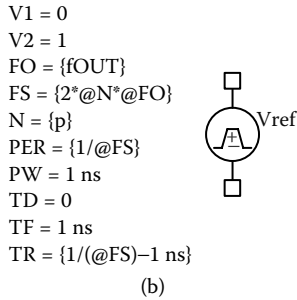
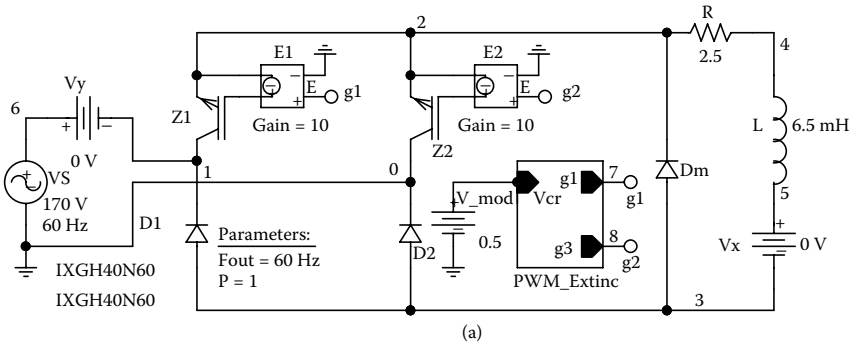
**FIGURE 11.24** Single-phase converter with extinction angle control. (a) Circuit, (b) gate voltages.

**EXAMPLE 11.7 FINDING THE PERFORMANCE OF A SINGLE-PHASE CONVERTER WITH AN EXTINCTION ANGLE CONTROL**

A single-phase converter with an extinction angle control is shown in Figure 11.24(a). The input voltage has a peak of 169.7 V, 60 Hz. The load inductance  $L$  is 6.5 mH, and the load resistance  $R$  is 0.5  $\Omega$ . The load battery voltage is  $V_x = 10$  V. The extinction angle is  $\beta = 60^\circ$ . Use PSpice to (a) plot the instantaneous output  $v_o$ , the load current  $i_o$ , and the input current  $i_s$  and (b) calculate the Fourier coefficients of the input current  $i_s$  and the input power factor PF.

**SOLUTION**

The conduction angles are generated with two carrier voltages as shown in Figure 11.24(b). Let us assume that  $A_r = 10$  V. For  $\beta = 60^\circ$ ,  $A_c = 10 \times 60/360 = 3.33$  V,



**FIGURE 11.25** PSpice schematic for Example 11.7. (a) Schematic, (b) schematic parameters.

and  $M = 3.33/10 = 0.333$ .  $v_c$  is generated by a PWL waveform, and  $v_r$  by a PULSE waveform.

The PSpice schematic with IGBTs is shown in Figure 11.25(a). Varying the modulation voltage  $V_{mod}$  can vary the output voltage. The output frequency {FOUT} of the modulating signal and the number of pulses P are defined as variables. The model parameters for the IGBTs and the freewheeling diode are as follows:

```

.MODEL IXGH40N60 NIGBT (TAU=287.56ns KP=50.034
AREA=37.5um AGD=18.75um
+ VT=4.1822 KF=.36047 CGS=31.942nf COXD=53.188nf
VTD=2.6570) for IGBTs

.MODEL DMD D(IS=2.22E-15 BV=1200V CJO=0PF TT=0US) for
Diodes
    
```

The parameters of the reference pulse signal can be adjusted to produce the triangular wave as shown in Figure 11.24(b). These parameters, as shown in Figure

11.25(b), are related to the supply frequency  $f$  and the number of pulse per half cycle  $p$  ( $p = 1$  for an extinction angle control) as follows: delay time  $t_d = 0$ , switching frequency  $f_s = 2pf$ , switching period  $T_s = 1/f_s$ , pulse width  $t_w = 1$  nsec, rise time  $t_r = (1/f_s) - 1$  nsec, and fall time  $t_f = 1$  nsec.

The listing of the circuit file for the converter is as follows:

---

### Example 11.7 Single-phase semiconverter with extinction angle control

```

VS 6 0 AC 0 SIN (0 170V 60Hz 0 0 0)
.PARAM FOUT=60Hz P=1 M=0.6
* Parameters: fout = output frequency and p = # of pulses per half
cycle
Vref 10 0 PULSE (0 1 0 {1/({2*{p}*{fout}})-1ns} 1ns
+ 1ns {1/({2*{p}*{fout}})}); Reference Signal
V_mod 11 0 DC {M}; Modulation signal
E_ABS 12 0 VALUE {ABS(V(11))}; Carrier signal
R 2 4 2.5 ; Load Resistance
L 4 5 6.5mH ; Load Inductance
Vx 5 3 0V ; Measues the load current
Vy 6 1 0V ; Measues the input current
D1 3 1 DMD ; Diodes with model DMD
D2 3 0 DMD
Dm 3 2 DMD
.MODEL DMD D(IS=1E-25 BV=1000V); Diode model parameters
Z1 1 7 2 IXGH40N60 ; IGBTs with a model IXGH40N60
Z2 0 8 2 IXGH40N60
.MODEL IXGH40N60 NIGBT (TAU=287.56ns KP=50.034 AREA=37.5um
AGD=18.75um
+ VT=4.1822 KF=.36047 CGS=31.942nf COXD=53.188nf VTD=2.6570)
E1 7 2 g1 0 10 ; Voltage-controlled voltage source
E2 8 2 g2 0 10 ; Voltage-controlled voltage source
XPWM 10 12 g1 g2 PWM ; Control voltages g1 and g3
* Subcircuit PWM, which is missing, must be inserted
.TRAN 1US 50MS 33.33MS 0.1E-6 ; Transient analysis
.FOUR 60 10 I(Vy) ; Fourier analysis
.OPTIONS ABSTOL= 10u CHGTOL= 0.01nC RELTOL= 0.1 TNOM= 1m VNTOL= 0.1
.PROBE ; Graphics post-processor
.END

```

---

Note the following:

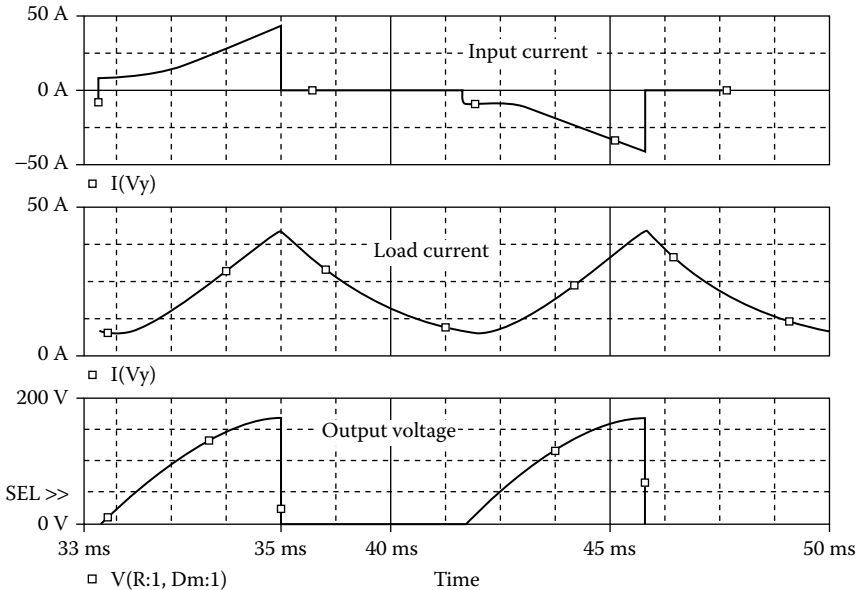
- (a) The PSpice plots of the instantaneous output voltage  $V(2, 3)$ , the load current  $I(VX)$ , and the input current  $I(VY)$  are shown in Figure 11.26. The input current is not symmetrical about the 0-axis, and its shape depends on the load current.
- (b) The Fourier series of the input current is as follows:

**FOURIER COMPONENTS OF TRANSIENT RESPONSE I(VY)**

DC COMPONENT =  $-8.990786E-02$

Harmonic No	Frequency (Hz)	Fourier Component	Normalized Component	Phase (Deg)	Normalized Phase (Deg)
1	6.000E+01	3.078E+01	1.000E+00	1.338E+01	0.000E+00
2	1.200E+02	1.281E-01	4.163E-03	1.912E+01	5.742E+00
3	1.800E+02	1.057E+01	3.434E-01	1.779E+02	1.645E+02
4	2.400E+02	1.335E-01	4.338E-03	1.697E+02	1.564E+02
5	3.000E+02	6.870E+00	2.232E-01	-4.495E+01	-5.833E+01
6	3.600E+02	1.798E-01	5.841E-03	-8.377E+01	-9.714E+01
7	4.200E+02	5.066E+00	1.646E-01	5.811E+01	4.473E+01
8	4.800E+02	1.225E-01	3.980E-03	2.827E+01	1.490E+01
9	5.400E+02	2.582E+00	8.390E-02	-1.671E+02	-1.805E+02

TOTAL HARMONIC DISTORTION = 4.493854E+01 PERCENT



**FIGURE 11.26** Plots for Example 11.7 for delay angle  $\beta = 60^\circ$ .

Total harmonic distortion of input current  $THD = 44.93\% = 0.4493$

Displacement angle  $\phi_1 = 13.38$

Displacement factor  $DF = \cos \phi_1 = \cos(13.38) = 0.9728(\text{leading})$

The input power factor is

$$PF = \frac{1}{(1 + THD^2)^{1/2}} \cos \phi_1 = \frac{1}{(1 + 0.4493^2)^{1/2}} \times 0.9728 = 0.8873 \text{ (leading)}$$

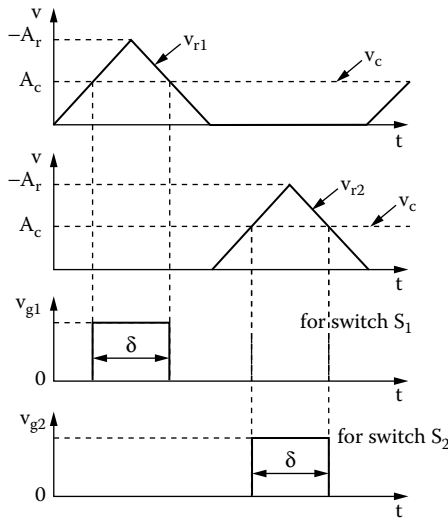
**EXAMPLE 11.8 FINDING THE PERFORMANCE OF A SINGLE-PHASE CONVERTER WITH A SYMMETRICAL ANGLE CONTROL**

A symmetrical angle control is applied to the converter of Figure 11.24(a). The input voltage has a peak of 169.7 V, 60 Hz. The load inductance  $L$  is 6.5 mH, and the load resistance  $R$  is 2.5  $\Omega$ . The load battery voltage is  $V_x = 10$  V. The conduction angle is  $\beta = 60^\circ$ . Use PSpice to (a) plot the instantaneous output voltage  $v_o$ , the load current  $i_o$ , and the input current  $i_s$ , and (b) calculate the Fourier coefficients of the input current  $i_s$  and the input power factor  $PF$ .

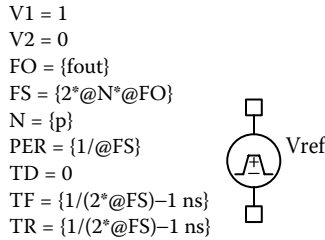
**SOLUTION**

The conduction angles can be generated with two carrier voltages as shown in Figure 11.27. Let us assume that  $A_r = 10$  V. For  $\beta = 60^\circ$ ,  $A_c = 10 \times 60/360 = 3.33$  V, and  $M = 3.33/10 = 0.333$ . The subcircuit PWM is used to generate control signals.  $v_r$  is generated by a PULSE generator with a very small pulse width, say,  $TW = 1NS$ .  $v_c$  is generated by a PWL generator.

The PSpice schematic is the same as that in Figure 11.25(a). The parameters of the reference pulse signal can be adjusted to give the triangular wave as shown in Figure



**FIGURE 11.27** Gate voltages with symmetrical angle control.



**FIGURE 11.28** Model parameters of the reference pulse signal for symmetrical angle control.

11.27. These parameters, as shown in Figure 11.28, are related to the supply frequency  $f$  and the number of pulse per half cycle  $p$  ( $p = 1$  for a symmetrical angle control) as follows: delay time  $t_d = 0$ , switching frequency  $f_s = 2pf$ , switching period  $T_s = 1/f_s$ , pulse width  $t_w = 1$  nsec, rise time  $t_r = (1/2f_s) - 1$  nsec, and fall time  $t_f = (1/2f_s) - 1$  nsec.

The listing of the circuit file is the same as that for Example 11.7, except that the statement for the reference signal is changed as follows:

```

Vref 10 0 PULSE ( 1 0 1ns {1/{2*{2*{p}*{fout}}}}
{1/{2*2*{p}*{fout}}} 1ns {1/{2*
+ {p}*{fout}}}) ; Reference SignalExample 11.8 Single-
phase semiconverter with symmetrical angle control
    
```

Note the following:

- (a) The PSpice plots of the instantaneous output voltage  $V(2, 3)$ , the load current  $I(VX)$ , and the input current  $I(VY)$  are shown in Figure 11.29. The output voltage is symmetrical, as expected.
- (b) The Fourier series of the input current is as follows:

---

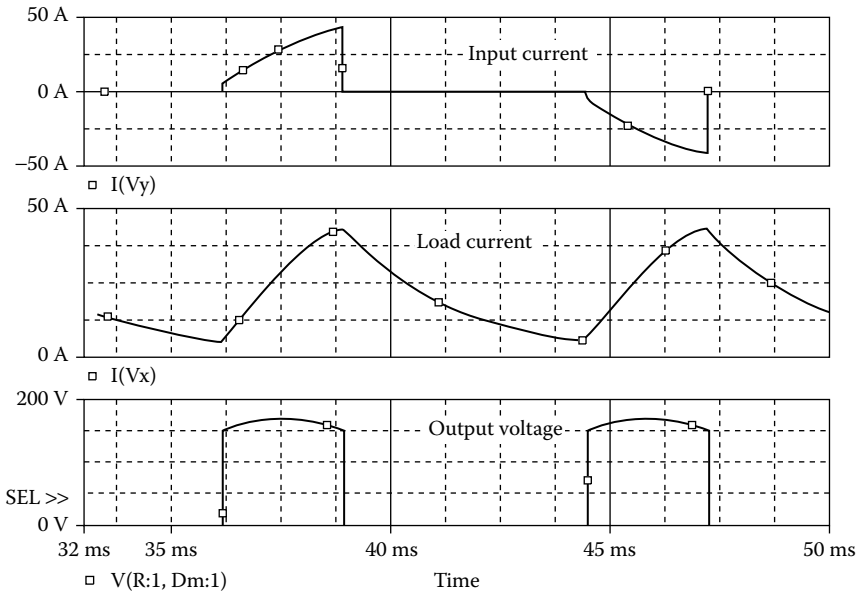
### FOURIER COMPONENTS OF TRANSIENT RESPONSE I(VY)

DC COMPONENT = 1.888986E-02

Harmonic No	Frequency (Hz)	Fourier Component	Normalized Component	Phase (Deg)	Normalized Phase (Deg)
1	6.000E+01	4.063E+01	1.000E+00	-1.143E+01	0.000E+00
2	1.200E+02	4.407E-02	1.085E-03	1.524E+02	1.639E+02
3	1.800E+02	9.826E+00	2.419E-01	1.115E+02	1.230E+02
4	2.400E+02	4.161E-02	1.024E-03	-1.490E+02	-1.376E+02
5	3.000E+02	7.352E+00	1.810E-01	1.630E+02	1.744E+02
6	3.600E+02	4.074E-02	1.003E-03	-8.388E+01	-7.245E+01
7	4.200E+02	4.407E+00	1.085E-01	-1.558E+02	-1.444E+02
8	4.800E+02	4.312E-02	1.061E-03	-2.285E+01	-1.142E+01
9	5.400E+02	2.517E+00	6.195E-02	-7.257E+01	-6.113E+01

TOTAL HARMONIC DISTORTION = 3.269051E+01 PERCENT

---



**FIGURE 11.29** Plots for Example 11.8 for delay angle  $\beta = 60^\circ$ .

Total harmonic distortion of input current  $\text{THD} = 32.69\% = 0.3269$   
 Displacement angle  $\phi_1 = -11.43^\circ$   
 Displacement factor  $\text{DF} = \cos \phi_1 = \cos(-11.434) = 0.98$  (lagging)

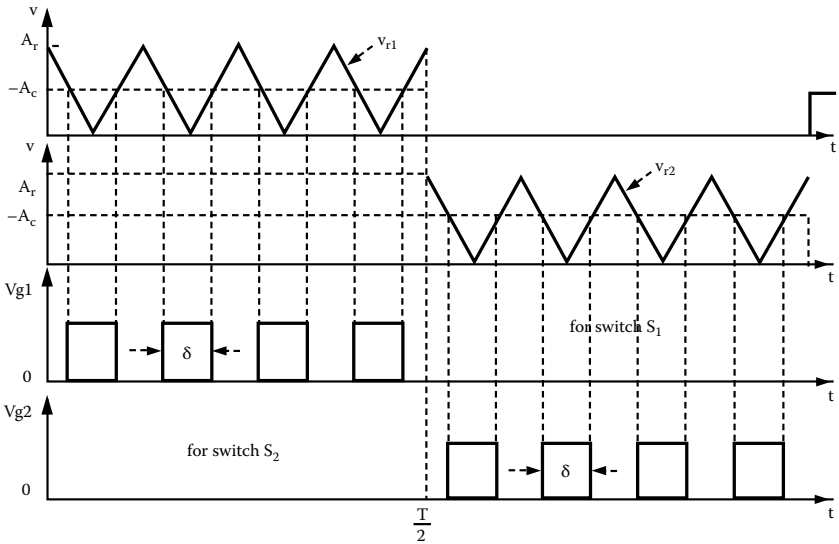
From Equation 7.3, the input power factor

$$\text{PF} = \frac{1}{(1 + \text{THD}^2)^{1/2}} \cos \phi_1 = \frac{1}{(1 + 0.3269^2)^{1/2}} \times 0.98 = 0.9315 \text{ (lagging)}$$

*Note:* The power factor of a converter with symmetrical angle control is better than that with extinction angle control for the same amount of pulse width or modulation index.

**EXAMPLE 11.9 FINDING THE PERFORMANCE OF A SINGLE-PHASE CONVERTER WITH A UNIFORM PWM CONTROL**

PWM control with four pulses per half cycle is applied to the converter of [Figure 11.24\(a\)](#). The input voltage has a peak of 169.7 V, 60 Hz. The load inductance  $L$  is 6.5 mH, and the load resistance  $R$  is 0.5  $\Omega$ . The load battery voltage is  $V_x = 10$  V. Use PSpice to (a) plot the instantaneous output voltage  $v_o$ , the load current  $i_o$ , and the input current  $i_s$  and (b) calculate the Fourier coefficients of the input current  $i_s$  and the input power factor PF. Assume a modulation index of 0.4.



**FIGURE 11.30** Gate voltages with PWM control.

### SOLUTION

The conduction angles are generated with two carrier voltages as shown in Figure 11.30. Assume that reference voltage  $V_r = 10$  V. For  $M = 0.4$ , the carrier voltage  $V_c = MV_r = 4$  V. We can use the same subcircuit PWM for generation of control signals. Note that the carrier voltages are generated with a PWL generator. Instead, we could use a PULSE generator with a very small pulse width, say,  $TW = 1$  nsec.

The PSpice schematic is the same as that in Figure 11.25(a). The parameters of the reference pulse signal can be adjusted to give the triangular wave as shown in Figure 11.30. These parameters, as shown in Figure 11.28, are related to the supply frequency  $f$  and the number of pulse per half cycle  $p$  as follows: delay time  $t_d = 0$ , switching frequency  $f_s = 2pf$ ; switching period  $T_s = 1/f_s$ , pulse width  $t_w = 1$  nsec, rise time  $t_r = 1/2f_s$ , and fall time  $t_f = (1/2f_s) - 1$  nsec.

The listing of the circuit file is the same as that for Example 11.8, except that the parameter  $p$  is changed to 4.

Note the following:

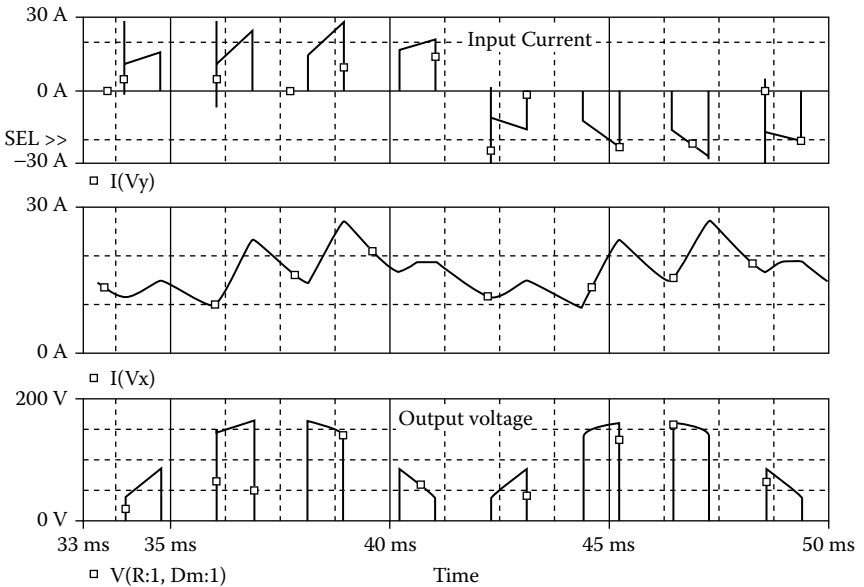
- The PSpice plots of the instantaneous output voltage  $V(2, 3)$ , the load current  $I(VX)$ , and the input current  $I(VY)$  are shown in Figure 11.31. The input current consists of four pulses per half cycle.
- The Fourier series of the input current is as follows:

**FOURIER COMPONENTS OF TRANSIENT RESPONSE I(VY)**

DC COMPONENT = 5.261076E-02

Harmonic No	Frequency (Hz)	Fourier Component	Normalized Component	Phase (Deg)	Normalized Phase (Deg)
1	6.000E+01	1.768E+01	1.000E+00	-1.163E+01	0.000E+00
2	1.200E+02	1.070E-01	6.051E-03	1.324E+02	1.441E+02
3	1.800E+02	4.811E+00	2.721E-01	1.433E+01	2.596E+01
4	2.400E+02	2.142E-01	1.212E-02	1.416E+00	1.305E+01
5	3.000E+02	4.184E+00	2.367E-01	-4.615E+00	7.015E+00
6	3.600E+02	2.012E-01	1.138E-02	1.386E+02	1.502E+02
7	4.200E+02	1.039E+01	5.876E-01	1.230E+00	1.286E+01
8	4.800E+02	1.529E-01	8.651E-03	1.689E+02	1.805E+02
9	5.400E+02	8.397E+00	4.750E-01	1.564E+02	1.681E+02

TOTAL HARMONIC DISTORTION = 8.374184E+01 PERCENT



**FIGURE 11.31** Plots for Example 11.9 for modulation index  $M = 0.4$ .

Total harmonic distortion of input current THD = 83.7% = 0.837

Displacement angle  $\phi_1 = -11.63^\circ$

Displacement factor DF =  $\cos \phi_1 = \cos(-11.63^\circ) = 0.979$  (lagging)

From Equation 7.3, the input power factor

$$PF = \frac{1}{(1 + THD^2)^{1/2}} \cos \phi_1 = \frac{1}{(1 + 0.837^2)^{1/2}} \times 0.979 = 0.75 \text{ (lagging)}$$

**EXAMPLE 11.10 FINDING THE PERFORMANCE OF A SINGLE-PHASE CONVERTER WITH A SINUSOIDAL PWM CONTROL**

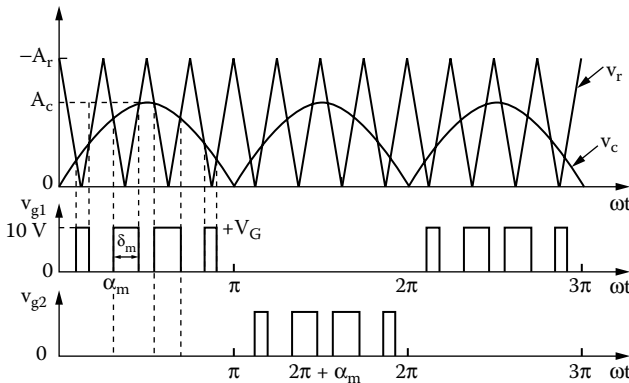
A sinusoidal pulse-width modulation (SPWM) control with four pulses per half cycle is applied to the converter of Figure 11.24(a). The input voltage has a peak of 169.7 V, 60 Hz. The load inductance  $L$  is 6.5 mH, and the load resistance  $R$  is 2.5  $\Omega$ . The load battery voltage is  $V_x = 10$  V. Use PSpice to (a) plot the instantaneous output voltage  $v_o$ , the load current  $i_o$ , and the input current  $i_s$  and (b) to calculate the Fourier coefficients of the input current  $i_s$  and the input power factor  $PF$ . Assume a modulation index of 0.4.

**SOLUTION**

The conduction angles are generated with two carrier voltages as shown in Figure 11.32. In this type of control, the carrier signal must be a rectified sine wave. PSpice generates only a sine wave. Thus, we can use a precision rectifier to convert a sine wave input signal to two sine wave pulses, and use a comparator to generate a PWM waveform.

The PSpice schematic is the same as that in Figure 11.25(a). The carrier signal must be a rectifier sinusoidal signal  $v_{cr} = |M \sin(2\pi ft)|$ , where  $f$  is the supply frequency and  $M$  the modulation index. The parameters of the reference pulse signal can be adjusted to give the triangular wave as shown in Figure 11.32. These parameters, as shown in Figure 11.33, are related to the supply frequency  $f$  and the number of pulse per half cycle  $p$  as follows: delay time  $t_d = 0$ , switching frequency  $f_s = 2pf$ , switching period  $T_s = 1/f_s$ , pulse width  $t_w = 1$  nsec, rise time  $t_r = 1/2f_s$ , and fall time  $t_f = (1/2f_s) - 1$  nsec.

We can use the subcircuit SPWM for generation of the control signals. The subcircuit definition for the sinusoidal modulation model SPWM is the same as that for PWM, except that the carrier signal must be a rectified sinusoidal signal of magnitude  $M$  at the supply frequency  $f$ .



**FIGURE 11.32** Gate voltages with SPWM control.

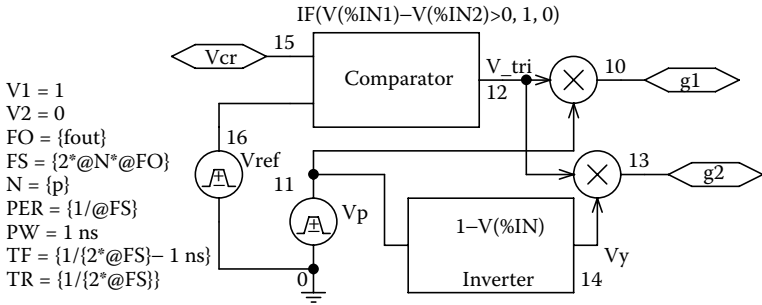


FIGURE 11.33 PSpice schematic SPWM signals.

Let us assume a reference voltage  $V_r = 10\text{ V}$ . For  $M = 0.4$ , the carrier voltage  $V_c = MV_r = 4\text{ V}$ . The listing of the circuit file is the same as that for Example 11.9, except that the statements for the carrier signal will be changed as follows:

```
V_mod 11 0 AC 0 SIN (0 {M} {fout} 0 0 0); Modulation signal
```

```
E_ABS 12 0 VALUE {ABS(V(11))} ; Absolute value of the carrier signal:
```

Note the following:

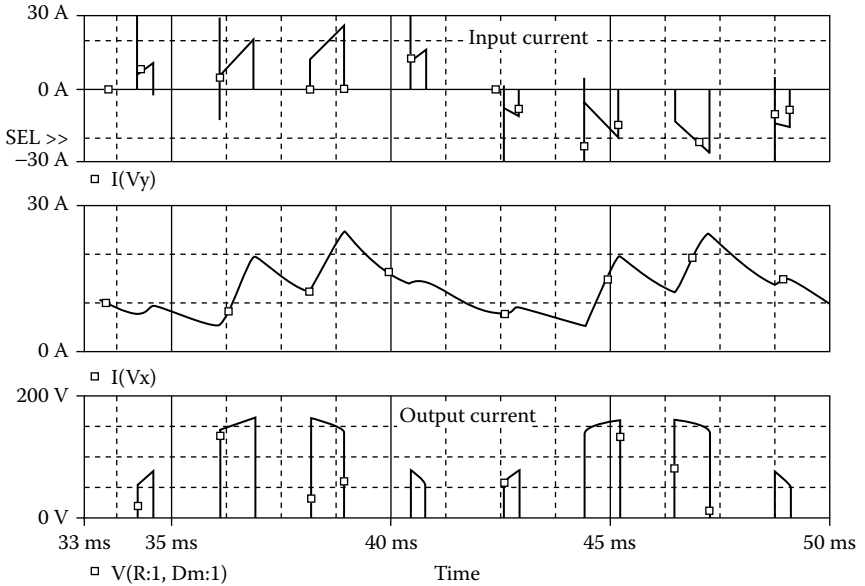
- (a) The PSpice plots of the instantaneous output voltage  $V(2, 3)$ , the load current  $I(VX)$ , and the input current  $I(VY)$  are shown in Figure 11.34. The input current pulses follow a sinusoidal pattern.
- (b) The Fourier series of the input current is as follows:

**FOURIER COMPONENTS OF TRANSIENT RESPONSE I(VY)**

DC COMPONENT =  $-3.111144\text{E}-02$

Harmonic No	Frequency (Hz)	Fourier Component	Normalized Component	Phase (Deg)	Normalized Phase (Deg)
1	6.000E+01	2.255E+01	1.000E+00	-1.127E+01	0.000E+00
2	1.200E+02	2.386E-01	1.058E-02	9.025E+00	2.029E+01
3	1.800E+02	8.748E+00	3.880E-01	6.041E+00	1.731E+01
4	2.400E+02	2.635E-01	1.169E-02	-1.781E+02	-1.668E+02
5	3.000E+02	4.986E+00	2.211E-01	1.760E+01	2.887E+01
6	3.600E+02	9.425E-02	4.180E-03	3.283E+01	4.410E+01
7	4.200E+02	5.257E+00	2.332E-01	1.662E+02	1.775E+02
8	4.800E+02	1.603E-01	7.111E-03	1.688E+02	1.801E+02
9	5.400E+02	1.184E+01	5.252E-01	-1.120E+01	7.249E-02

TOTAL HARMONIC DISTORTION =  $7.279670\text{E}+01$  PERCENT



**FIGURE 11.34** Plots for Example 11.10 for modulation index  $M = 0.4$ .

Total harmonic distortion of input current  $\text{THD} = 72.8\% = 0.728$

Displacement angle  $\phi_1 = -11.27^\circ$

Displacement factor  $\text{DF} = \cos \phi_1 = \cos(-11.27) = 0.9807$  (lagging)

From Equation 7.3, the input power factor

$$\text{PF} = \frac{1}{(1 + \text{THD}^2)^{1/2}} \cos \phi_1 = \frac{1}{(1 + 0.728^2)^{1/2}} \times 0.9807 = 0.7928 \text{ (lagging)}$$

*Note:* The power factor of a converter with sinusoidal PWM control is better than that with PWM control for the same amount of pulse width or modulation index.

## 11.8 LABORATORY EXPERIMENTS

It is possible to develop many experiments for demonstrating the operation and characteristics of thyristor-controlled rectifiers. The following experiments are suggested:

- Single-phase half-wave controlled rectifier
- Single-phase full-wave controlled rectifier
- Three-phase full-wave controlled rectifier

## 11.8.1 EXPERIMENT TC.1

### Single-Phase Half-Wave Controlled Rectifier

- Objective** To study the operation and characteristics of a single-phase half-wave (thyristor) controlled rectifier under various load conditions.
- Textbook** See [Reference 1](#), Section 10.2.
- Apparatus**
1. One phase-controlled thyristor with ratings of at least 50 A and 400 V, mounted on a heat sink
  2. One diode with ratings of at least 50 A and 400 V, mounted on a heat sink
  3. A firing pulse generator with isolating signals for gating thyristors
  4. An  $RL$  load
  5. One dual-beam oscilloscope with floating or isolating probes
  6. AC and DC voltmeters and ammeters and one noninductive shunt
  7. One isolation transformer
- Warning** Before making any circuit connection, switch off the AC power. Do not switch on the power unless the circuit is checked and approved by your laboratory instructor. Do not touch the thyristor heat sinks, which are connected to live terminals.

#### Part 1: Without Freewheeling Diode

- Experimental procedure**
1. Set up the circuit as shown in [Figure 11.35](#). Use the load resistance  $R$  only.
  2. Connect the measuring instruments as required.
  3. Connected the firing pulses to the appropriate thyristors.
  4. Set the delay angle to  $\alpha = \pi/3$ .
  5. Observe and record waveforms of the load voltage  $v_o$  and the load current  $i_o$ .
  6. Measure the average load voltage  $V_{o(\text{DC})}$ , the rms load voltage  $V_{o(\text{rms})}$ , the average load current  $I_{o(\text{DC})}$ , the rms load current  $I_{o(\text{rms})}$ , the rms input current  $I_{s(\text{rms})}$ , the rms input voltage  $V_{s(\text{rms})}$ , and the load power  $P_L$ .
  7. Measure the conduction angle of the thyristor  $T_1$ .
  8. Repeat steps 2 to 7 with the load inductance  $L$  only.
  9. Repeat steps 2 to 7 with both load resistance  $R$  and load inductance  $L$ .

#### Part 2: With Freewheeling Diode

- Experimental procedure**
1. Set up the circuit as shown in [Figure 11.35](#) with a freewheeling diode across the load as shown by the dashed lines.
  2. Repeat the steps in Part 1.
- Report**
1. Present all recorded waveform and discuss all significant points.
  2. Compare the waveforms generated by SPICE with the experimental results, and comment.
  3. Compare the experimental results with the predicted results.
  4. Calculate and plot the average output voltage  $V_{o(\text{DC})}$  and the input power factor PF against the delay angle  $\alpha$ .
  5. Discuss the advantages and disadvantages of this type of rectifier.
  6. Discuss the effects of the freewheeling diode on the performance of the rectifier.

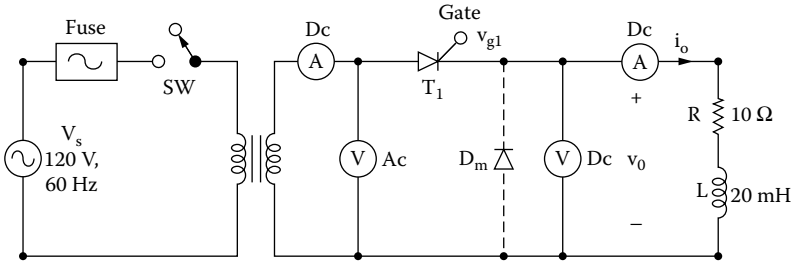


FIGURE 11.35 Single-phase half-wave controlled rectifier.

### 11.8.2 EXPERIMENT TC.2

#### Single-Phase Full-Wave Controlled Rectifier

**Objective** To study the operation and characteristics of a single-phase full-wave (thyristor) controlled rectifier under various load conditions.

**Applications** The single-phase full-wave controlled rectifier is used to control power flow power supplies, variable-speed DC motor drives, input stages of other converters, etc.

**Textbook** See Reference 1, Section 10.3 and Section 10.4.

- Apparatus**
1. Four phase-controlled thyristors with ratings of at least 50 A and 400 V, mounted on heat sinks
  2. One diode with ratings of at least 50 A and 400 V, mounted on a heat sink
  3. A firing pulse generator with isolating signals for gating thyristors
  4. An *RL* load
  5. One dual-beam oscilloscope with floating or isolating probes
  6. AC and DC voltmeters and ammeters and one noninductive shunt

**Warning** See Experiment TC.1.

**Experimental procedure** Set up the circuit as shown in Figure 11.36. Repeat the steps in Parts 1 and 2 of

Experiment TC.1 on the single-phase half-wave controlled rectifier.

**Report** Repeat the steps in Experiment TC.1 for the single-phase half-wave controlled rectifier.

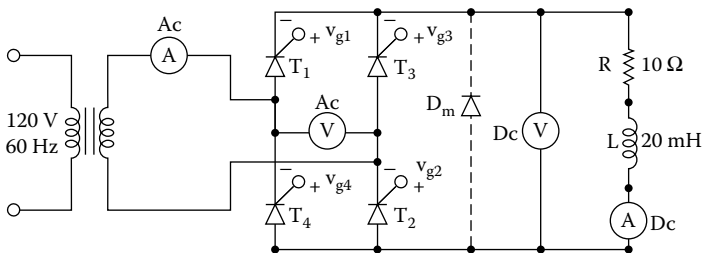


FIGURE 11.36 Single-phase full-wave controlled rectifier.

### 11.8.3 EXPERIMENT TC.3

#### Three-Phase Full-Wave Controlled Rectifier

**Objective** To study the operation and characteristics of a three-phase full-wave (thyristor) controlled rectifier under various load conditions.

**Applications** The three-phase full-wave controlled rectifier is used to control power flow power supplies, variable-speed DC motor drives, input stages of other converters, etc.

**Textbook** See Reference 1, Section 10.6 and Section 10.7.

- Apparatus**
1. Six phase-controlled thyristors with ratings of at least 50 A and 400 V, mounted on heat sinks
  2. One diode with ratings of at least 50 A and 400 V, mounted on a heat sink
  3. A firing pulse generator with isolating signals for gating thyristors
  4. An *RL* load
  5. One dual-beam oscilloscope with floating or isolating probes
  6. AC and DC voltmeters and ammeters and one noninductive shunt

**Warning** See Experiment TC.1.

**Experimental procedure** Set up the circuit as shown in Figure 11.37. Repeat the steps in Parts 1 and 2 for

- Report**
1. Present all recorded waveform and discuss all significant points.
  2. Compare the waveforms generated by SPICE with the experimental results, and comment.
  3. Compare the experimental results with the predicted results.
  4. Discuss the advantages and disadvantages of this type of rectifier.
  5. Discuss the effects of the freewheeling diode on the performance of the rectifier.

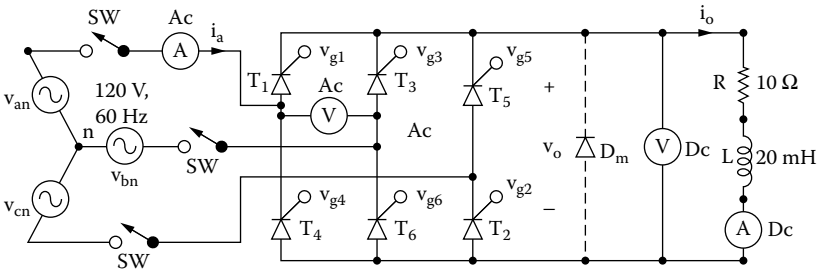


FIGURE 11.37 Three-phase full-wave controlled rectifier.

#### SUMMARY

The statements for an AC thyristor are as follows:

```
* Subcircuit call for switched thyristor model:
XT1    NA    NK    +NG    -NG    SCR
      anode cathode +control -control model
*
      voltage voltage name
```

```

* Subcircuit call for PWM control:
XPW  VR      VC      +NG      -NG      PWM
*   ref.    carrier +control -control model
*   input   input  voltage  voltage  name
* Subcircuit calls for sinusoidal PWM control:
XSPW  VR      VS      +NG      -NG      VC      SPWM
*   ref.  sine-wave +control -control  rectified  model
*   input input   voltage  voltage  carrier sine wave  name

```

## Suggested Reading

1. M.H. Rashid, *Power Electronics - Circuits, Devices and Applications*, 3rd ed., Englewood Cliffs, NJ: Prentice-Hall, 2003, Sec. 7.11 and chap. 10.
2. M. H. Rashid, *Introduction to PSpice Using OrCAD for Circuits and Electronics*, (3rd ed) Englewood Cliffs, NJ: Prentice-Hall, 2003, chap. 6.
3. L.J. Giacoletto, Simple SCR and TRIAC PSPICE computer models, *IEEE Transactions on Industrial Electronics*, Vol. 36, No. 3, August 1989, pp. 451–455.
4. Goce L. Arsov, Comments on A nonideal macromodel of thyristor for transient analysis in power electronics, *IEEE Transactions on Industrial Electronics*, Vol. 39, No. 2, April 1992, pp. 175–176.
5. F.J. Garcia, F. Arizti, and F.J. Aranceta, A nonideal macromodel of thyristor for transient analysis in power electronics, *IEEE Transactions on Industrial Electronics*, Vol. 37, No. 6, December 1990, pp. 514–520.
6. R.L. Avant and F.C.Y. Lee, The J3 SCR model applied to resonant converter simulation, *IEEE Transactions on Industrial Electronics*, Vol. 32, No. 1, February 1985, pp. 1–12.
7. E.Y. Ho and P.C. Sen, Effect of gate drive on GTO thyristor characteristics, *IEEE Transactions on Industrial Electronics*, Vol. IE33, No. 3, 1986, pp. 325–331.
8. M.A.I. El-Amin, GTO PSPICE Model and its applications, *The Fourth Saudi Engineering Conference*, November 1995, Vol. III, pp. 271–277.
9. G. Busatto, F. Iannuzzo, and L. Fratelli, PSPICE model for GTOs, *Proceedings of Symposium on Power Electronics Electrical Drives, Advanced Machine Power Quality*. SPEEDAM Conference, June 3–5, 1998, Sorrento, Italy, Col. 1, pp. P2/5–10.

## DESIGN PROBLEMS

### 11.1

Design the single-phase semiconverter of [Figure 11.7\(a\)](#) with the following specifications:

AC supply voltage  $V_s = 120 \text{ V (rms)}$ , 60 Hz

Load resistance  $R = 5 \Omega$

Load inductance  $L = 15 \text{ mH}$

DC output voltage  $V_{o(\text{DC})} = 80\%$  of the maximum value

- (a) Determine the ratings of all components and devices under worst-case conditions.
- (b) Use SPICE to verify your design.
- (c) Provide a cost estimate of the circuit.

## 11.2

- (a) Design an output  $C$  filter for the single-phase semiconverter of Problem 11.1. The harmonic content of the load current should be less than 5% of the value without the filter.
- (b) Use SPICE to verify your design in part (a).

## 11.3

Design the single-phase full converter of [Figure 11.10\(a\)](#) with the following specifications:

AC supply voltage  $V_s = 120$  V (rms), 60 Hz

Load resistance  $R = 5 \Omega$

Load inductance  $L = 15$  mH

DC output voltage  $V_{o(\text{DC})} = 80\%$  of the maximum value

- (a) Determine the ratings of all components and devices under worst-case conditions.
- (b) Use SPICE to verify your design.
- (c) Provide a cost estimate of the circuit.

## 11.4

- (a) Design an output  $C$  filter for the single-phase semiconverter of Problem 11.3. The harmonic content of the load current should be less than 5% of the value without the filter.
- (b) Use SPICE to verify your design in part (a).

## 11.5

Design the three-phase semiconverter of [Figure 11.16\(a\)](#) with the following specifications:

AC supply voltage per phase,  $V_s = 120$  V (rms), 60 Hz

Load resistance  $R = 5 \Omega$

Load inductance  $L = 15$  mH

DC output voltage  $V_{o(\text{DC})} = 80\%$  of the maximum value

- (a) Determine the ratings of all components and devices under worst-case conditions.
- (b) Use SPICE to verify your design.
- (c) Provide a cost estimate of the circuit.

## 11.6

- (a) Design an output  $C$  filter for the three-phase semiconverter of Problem 11.5. The harmonic content of the load current should be less than 5% of the value without the filter.
- (b) Use SPICE to verify your design in part (a).

## 11.7

Design the three-phase full-bridge converter of [Figure 11.19\(a\)](#) with the following specifications:

AC supply voltage per phase,  $V_s = 120$  V (rms), 60 Hz

Load resistance  $R = 5 \Omega$

Load inductance  $L = 15$  mH

DC output voltage  $V_{o(\text{DC})} = 80\%$  of the maximum value

- (a) Determine the ratings of all components and devices under worst-case conditions.
- (b) Use SPICE to verify your design.
- (c) Provide a cost estimate of the circuit.

## 11.8

- (a) Design an output  $C$  filter for the converter of Problem 11.7. The harmonic content of the load current should be less than 5% of the value without the filter.
- (b) Use SPICE to verify your design in part (a).

## 11.9

Use PSpice to find the worst-case minimum and maximum output voltages  $V_{o(\text{max})}$  and  $V_{o(\text{min})}$  for Problem 11.1. Assume uniform tolerances of  $\pm 15\%$  for all passive elements and an operating temperature of  $25^\circ\text{C}$ .

## 11.10

Use PSpice to find the worst-case minimum and maximum output voltages  $V_{o(\text{max})}$  and  $V_{o(\text{min})}$  for Problem 11.2. Assume uniform tolerances of  $\pm 15\%$  for all passive elements and an operating temperature of  $25^\circ\text{C}$ .

## 11.11

Use PSpice to find the worst-case minimum and maximum output voltages  $V_{o(\text{max})}$  and  $V_{o(\text{min})}$  for Problem 11.3. Assume uniform tolerances of  $\pm 15\%$  for all passive elements and an operating temperature of  $25^\circ\text{C}$ .

**11.12**

Use PSpice to find the worst-case minimum and maximum output voltages  $V_{o(\max)}$  and  $V_{o(\min)}$  for Problem 11.4. Assume uniform tolerances of  $\pm 15\%$  for all passive elements and an operating temperature of  $25^\circ\text{C}$ .

**11.13**

Use PSpice to find the worst-case minimum and maximum output voltages  $V_{o(\max)}$  and  $V_{o(\min)}$  for Problem 11.5. Assume uniform tolerances of  $\pm 15\%$  for all passive elements and an operating temperature of  $25^\circ\text{C}$ .

**11.14**

Use PSpice to find the worst-case minimum and maximum output voltages  $V_{o(\max)}$  and  $V_{o(\min)}$  for Problem 11.6. Assume uniform tolerances of  $\pm 15\%$  for all passive elements and an operating temperature of  $25^\circ\text{C}$ .

**11.15**

Use PSpice to find the worst-case minimum and maximum output voltages  $V_{o(\max)}$  and  $V_{o(\min)}$  for Problem 11.7. Assume uniform tolerances of  $\pm 15\%$  for all passive elements and an operating temperature of  $25^\circ\text{C}$ .

**11.16**

Use PSpice to find the worst-case minimum and maximum output voltages  $V_{o(\max)}$  and  $V_{o(\min)}$  for Problem 11.8. Assume uniform tolerances of  $\pm 15\%$  for all passive elements and an operating temperature of  $25^\circ\text{C}$ .

# 12 AC Voltage Controllers

The learning objectives of this chapter are:

- Modeling SCRs for AC applications and specifying their mode parameters
- Modeling voltage-controlled switches
- Performing transient analysis of AC voltage controllers
- Evaluating the performance of AC voltage controllers
- Performing worst-case analysis of AC voltage controllers for parametric variations of model parameters and tolerances

## 12.1 INTRODUCTION

The input voltage and output current of AC voltage controllers pass through the value zero in every cycle. This simplifies the modeling of a thyristor. A thyristor can be turned on by applying a pulse of short duration, and it is turned off by natural commutation due to the characteristics of the input voltage and the current. Pulse-width modulation (PWM) techniques can be applied to AC voltage controllers with bidirectional switches in order to improve the input power factor of the converters.

## 12.2 AC THYRISTOR MODEL

The load current of AC voltage controllers is AC, and the current of a thyristor always passes through zero. There being no need for the diode  $D_T$  of Figure 11.1(b), the thyristor model can be simplified to Figure 12.1. This model can be used as a subcircuit. Switch  $S_1$  is controlled by the controlling voltage  $V_R$  connected between nodes 6 and 2. The switch parameters can be adjusted to yield the desired on-state voltage drop across the thyristor. In the following examples, we will use the switch parameters  $RON = 0.01$ ,  $ROFF = 10E+5$ ,  $VON = 0.1V$ , and  $VOFF = 0V$ . The other parameters are discussed in Section 11.2.

The subcircuit definition for the thyristor model ASCR can be described as follows:

---

```
* Subcircuit for AC thyristor model
.SUBCKT ASCR 1 2 3 2
*      model anode cathode +control -control
*      name          voltage  voltage
S1 1 5 6 2 SMOD ; Switch
```

```

RG      3      4      50
VX      4      2      DC    0V
VY      5      2      DC    0V
RT      2      6      1
CT      6      2      10UF
F1      2      6      POLY(2)  VX  VY  0  50  11
.MODEL  SMOD  VSWITCH  (RON=0.01  ROFF=10E+5  VON=0.1V  VOFF=0V)
.ENDS  ASCR ; Ends subcircuit definition
    
```

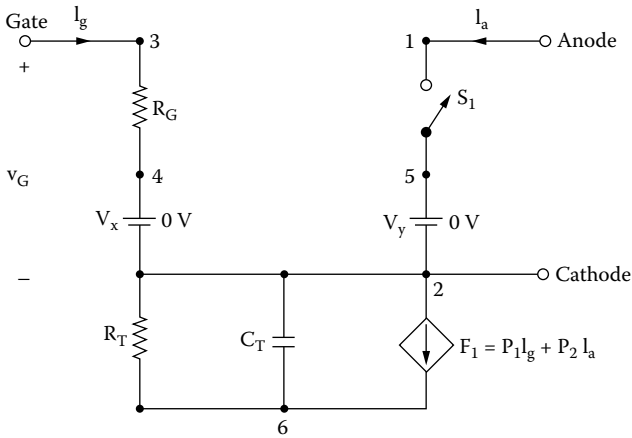


FIGURE 12.1 AC thyristor model.

### 12.3 AC VOLTAGE CONTROLLERS

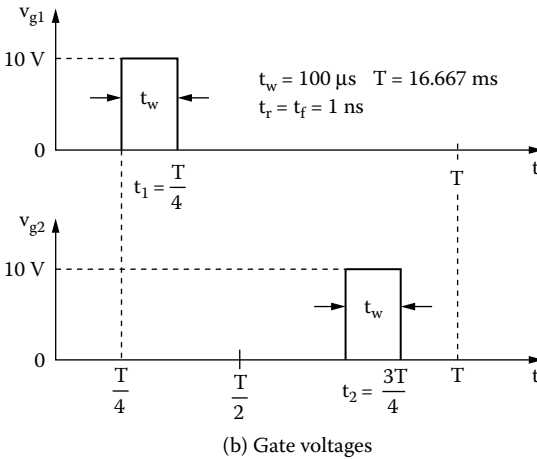
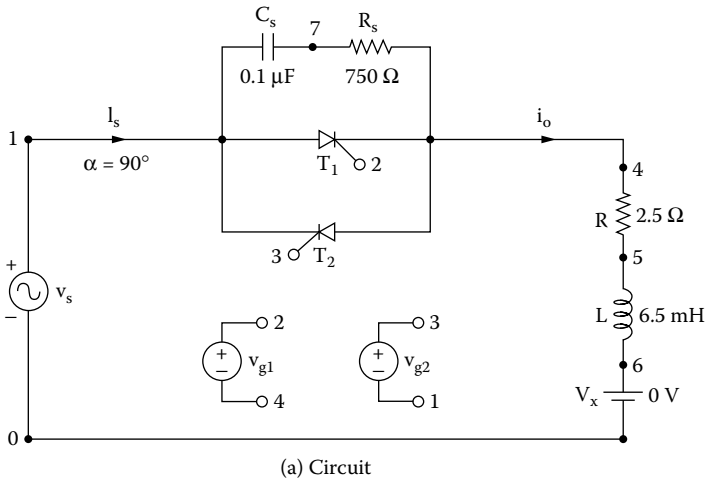
The input to an AC voltage controller is a fixed AC voltage, and its output is a variable AC voltage. When the converter switches are turned on, the input voltage is connected to the load. The output voltage, which is varied by changing the conduction time of the switches, is discontinuous. The input power factor is low.

### 12.4 EXAMPLES OF AC VOLTAGE CONTROLLERS

The applications of the AC thyristor model are illustrated by the following examples.

#### EXAMPLE 12.1 FINDING THE PERFORMANCE OF A SINGLE-PHASE FULL-WAVE AC VOLTAGE CONTROLLER

A single-phase full-wave AC voltage controller is shown in Figure 12.2(a). The input voltage has a peak of 169.7 V, 60 Hz. The load inductance  $L$  is 6.5 mH, and



**FIGURE 12.2** Single-phase full-wave AC voltage-controller for PSpice simulation. (a) Circuit, (b) gate voltages.

the load resistance  $R$  is  $2.5 \Omega$ . The delay angles are equal:  $\alpha_1 = \alpha_2 = 90^\circ$ . The gate voltages are shown in Figure 12.2(b). Use PSpice to (a) plot the instantaneous output voltage  $v_o$  and the load current  $i_o$  and (b) calculate the Fourier coefficients of the input current  $i_s$  and the input power factor  $PF$ .

**SOLUTION**

The peak supply voltage,  $V_m = 169.7 \text{ V}$ . For  $\alpha_1 = \alpha_2 = 90^\circ$ , time delay  $t_1 = (90/360) \times (1000/60 \text{ Hz}) \times 1000 = 4166.7 \text{ } \mu\text{s}$ . A series snubber with  $C_s = 0.1 \text{ } \mu\text{F}$  and  $R_s = 750 \text{ } \Omega$  is connected across the thyristor to cope with the transient voltage due to the inductive load.

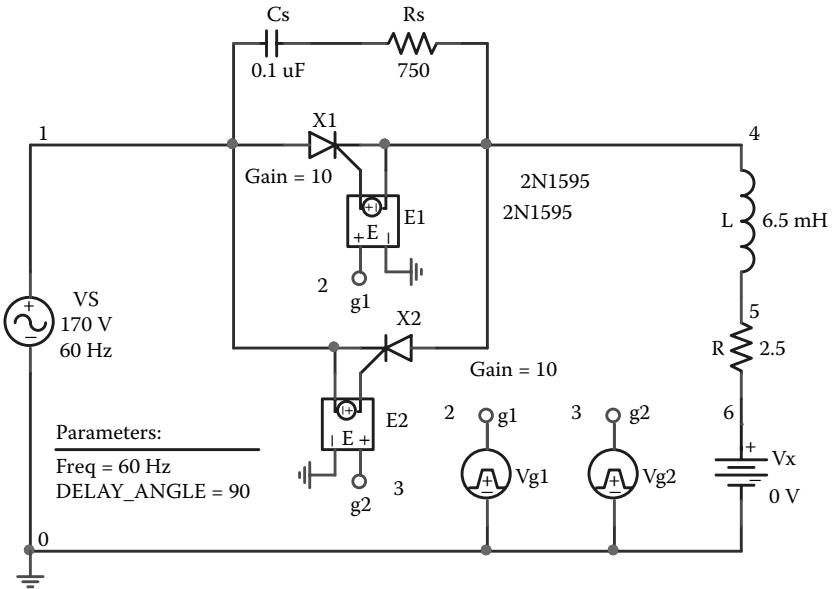


FIGURE 12.3 PSpice schematic for Example 12.1.

The PSpice schematic with an SCR is shown in Figure 12.3. The model name of the SCR, 2N1595, is changed to ASCR, whose subcircuit definition is listed in Section 12.2. By varying the delay cycle, the output voltage can be changed. The supply frequency {FREQ} and the duty cycle {DELAY\_ANGLE} are defined as variables.

The listing of the circuit file is as follows:

### Example 12.1 Single-phase AC voltage controller

```

SOURCE  ■ VS 1 0 SIN (0 169.7V 60HZ)
        .PARAM DELAY_ANGLE=90 FREQ=60Hz
        Vg1 2 4 PULSE ( 0 10 {{Delay_Angle}}/{360*{FREQ}}) 1ns 1ns
        100us {1/{FREQ}} )
        Vg2 3 1 PULSE ( 0 10 {{(Delay_Angle)+180}}/{360*{FREQ}})
        1ns 1ns 100us {1/{FREQ}})
CIRCUIT  ■ R 4 5 2.5
        L 5 6 6.5MH
        VX 6 0 DC 0V ; Voltage source to measure the load current
        CS 1 7 0.1UF
        RS 7 4 750
        * Subcircuit call for thyristor model:
  
```

```
XT1 1 4 2 4 ASCR ; Thyristor T1
```

```
XT2 4 1 3 1 ASCR ; Thyristor T2
```

```
* Subcircuit ASCR, which is missing, must be inserted.
```

```
ANALYSIS ■■■ .TRAN 1US 33.33MS ; Transient analysis
```

```
.PROBE ; Graphics post-processor
```

```
.OPTIONS ABSTOL = 1.00N RELTOL = 1.0M VNTOL = 1.0M
```

```
ITL5 = 10000 ;
```

```
*
```

```
Convergence
```

```
.FOUR 60HZ I(VX) ; Fourier analysis
```

```
.END
```

Note the following:

- The PSpice plots of instantaneous output voltage V(4) and load current I(VX) are shown in [Figure 12.4](#). The output voltage and current are discontinuous.
- The Fourier series of the input current, which is the same as the current through source VX, is as follows:

### FOURIER COMPONENTS OF TRANSIENT RESPONSE I(VX)

DC COMPONENT =  $-1.312521\text{E}-04$

Harmonic No	Frequency (Hz)	Fourier Component	Normalized Component	Phase (Deg)	Normalized Phase (Deg)
1	6.000E+01	2.883E+01	1.000E+00	-6.244E+01	0.000E+00
2	1.200E+02	1.068E-04	3.704E-06	1.714E+01	7.958E+01
3	1.800E+02	7.966E+00	2.763E-01	-2.494E+00	5.995E+01
4	2.400E+02	9.049E-05	3.139E-06	-1.676E+02	-1.052E+02
5	3.000E+02	2.671E+00	9.265E-02	-1.472E+02	-8.473E+01
6	3.600E+02	3.556E-05	1.233E-06	3.215E+01	9.459E+01
7	4.200E+02	4.161E-01	1.443E-02	3.990E+01	1.023E+02
8	4.800E+02	3.673E-05	1.274E-06	1.672E+02	2.296E+02
9	5.400E+02	5.995E-01	2.079E-02	1.496E+02	2.120E+02

TOTAL HARMONIC DISTORTION =  $2.925271\text{E}+01$  PERCENT

Total harmonic distortion of input current THD =  $29.25\% = 0.2925$

Displacement angle  $\phi_1 = -62.44^\circ$

Displacement factor DF =  $\cos \phi_1 = \cos(-62.44) = 0.4627$  (lagging)

From Equation 7.3, the input power factor is

$$\text{PF} = \frac{1}{(1 + \text{THD}^2)^{1/2}} \cos \phi_1 = \frac{1}{(1 + 0.2925^2)^{1/2}} \times 0.4627 = 0.444 \text{ (lagging)}$$

*Note:* The input power will decrease with the delay angle of the converter.

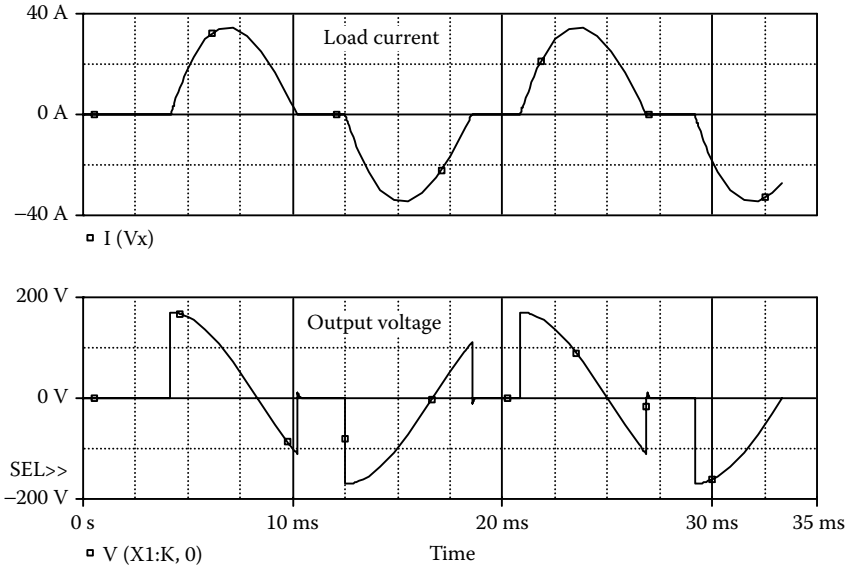


FIGURE 12.4 Plots for Example 12.1 for delay angle  $\alpha = 90^\circ$ .

**EXAMPLE 12.2 FINDING THE PERFORMANCE OF A THREE-PHASE HALF-WAVE AC VOLTAGE CONTROLLER**

A single-phase half-wave AC voltage controller is supplied from a three-phase wye-connected supply as shown in Figure 12.5(a). The input phase voltage has a peak of 169.7 V, 60 Hz. The load resistance per phase is  $R = 2.5 \Omega$ . The delay angle is  $\alpha = 60^\circ$ . The gate voltages are shown in Figure 12.5(b). Use PSpice to (a) plot the instantaneous output phase voltage  $v_o$  and (b) calculate the Fourier coefficients of the input phase current  $i_s$  and the input power factor  $PF$ .

**SOLUTION**

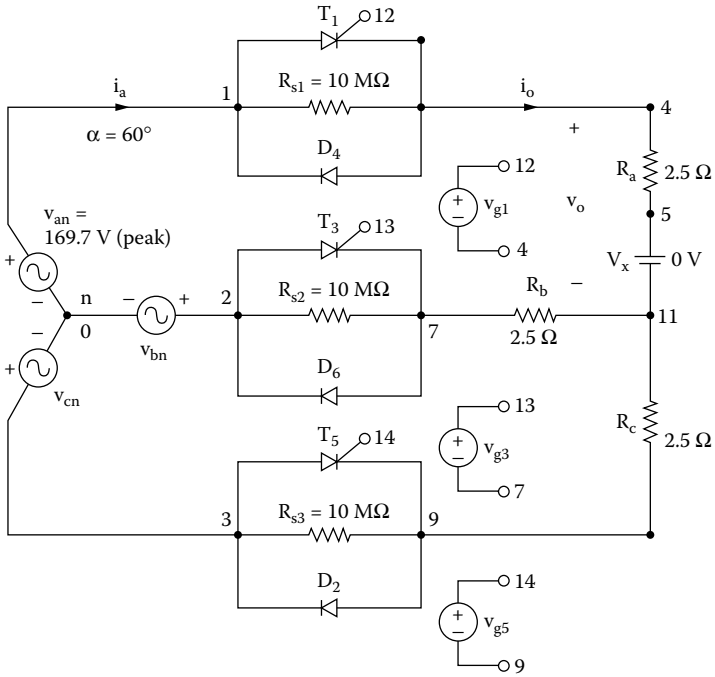
The peak supply voltage per phase  $V_m = 169.7$  V. For  $\alpha = 60^\circ$ ,

$$\text{time delay } t_1 = \frac{60}{360} \times \frac{1000}{60 \text{ Hz}} \times 1000 = 2777.78 \mu\text{sec}$$

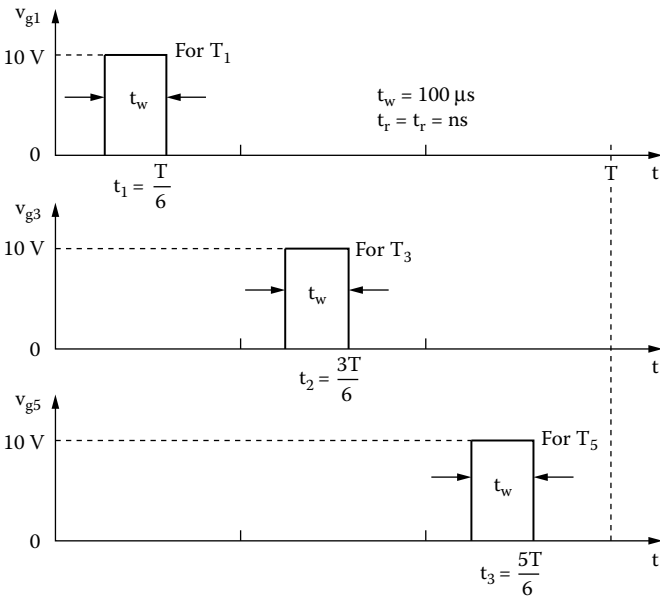
$$\text{time delay } t_2 = \frac{180}{360} \times \frac{1000}{60 \text{ Hz}} \times 1000 = 8333.3 \mu\text{sec}$$

$$\text{time delay } t_3 = \frac{300}{360} \times \frac{1000}{60 \text{ Hz}} \times 1000 = 13,888.9 \mu\text{sec}$$

The PSpice schematic with SCRs is shown in Figure 12.6. The model name of the SCR, 2N1595, is changed to ASCR, whose subcircuit definition is listed in Section



(a) Circuit



(b) Gate voltages

**FIGURE 12.5** Three-phase half-wave AC controller for PSpice simulation. (a) Circuit, (b) gate voltages.

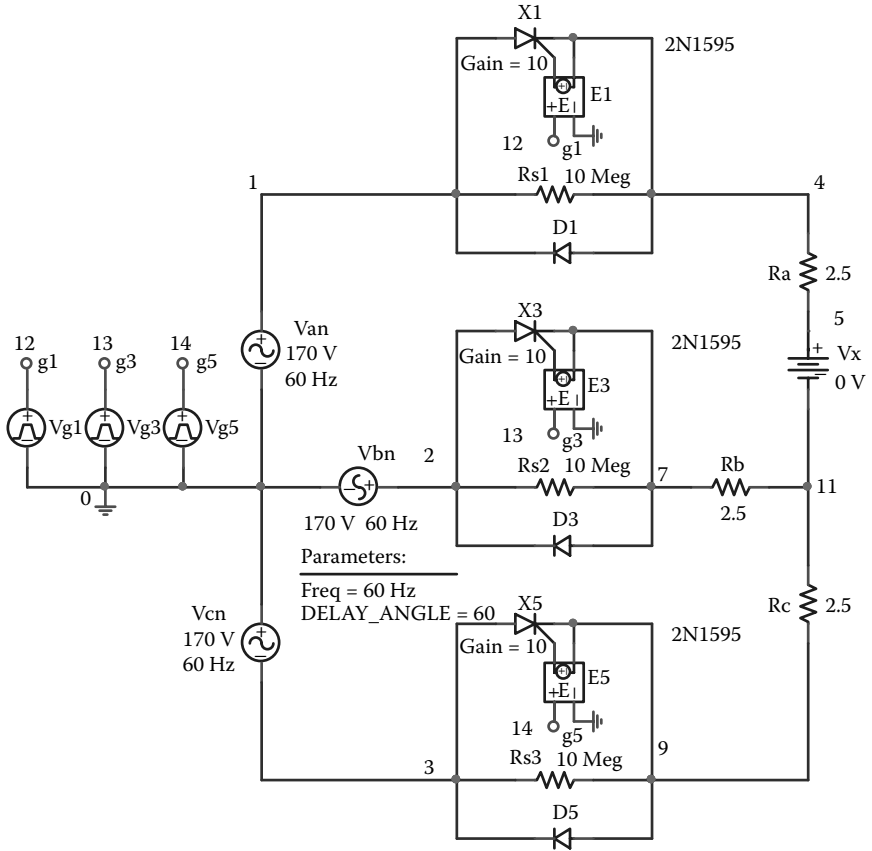


FIGURE 12.6 PSpice schematic for Example 12.2.

12.2. By varying the delay cycle, the output voltage can be changed. The supply frequency {FREQ} and the duty cycle {DELAY\_ANGLE} are defined as variables. The model parameters for the diodes are as follows:

```
.MODEL DMD D(IS=2.22E-15 BV=1200V CJO=0PF TT=0US) for diodes
```

The listing of the circuit file is as follows:

**Example 12.2 Three-phase half-wave AC voltage controller**

```
SOURCE ■ Van 1 0 SIN (0 169.7V 60HZ)
        Vbn 2 0 SIN (0 169.7V 60HZ 0 0 -120DEG)
        Vcn 3 0 SIN (0 169.7V 60HZ 0 0 -240DEG)
```

```

.PARAM DELAY_ANGLE=60 FREQ=60Hz
Vg1 12 4 PULSE ( 0 10 {{Delay_Angle}}/{360*{FREQ}}) 1ns
1ns 100us{1/{FREQ}} )
Vg3 13 7 PULSE (0 10 {{{Delay_Angle}+120}}/{360*{FREQ}})
1ns 1ns 100us {1/{FREQ}})
Vg5 14 9 PULSE (0 10 {{{Delay_Angle}+240}}/{360*{FREQ}})
1ns 1ns 100us {1/{FREQ}})
CIRCUIT ■■ Rs1 1 4 10MEG
Rs2 2 7 10MEG
Rs3 3 9 10MEG
Ra 4 5 2.5
VX 5 11 DC 0V ; To measure load current
Rb 7 11 2.5
Rc 9 11 2.5
* Subcircuit calls for thyristor model:
XT1 1 4 12 4 ASCR ; Thyristor T1
XT3 2 7 13 7 ASCR ; Thyristor T3
XT5 3 9 14 9 ASCR ; Thyristor T5
D2 9 3 DMOD ; Diode
D4 4 1 DMOD ; Diode
D6 7 2 DMOD ; Diode
.MODEL DMOD D (IS=2.22E-15 BV=1200V IBV=13E-3 CJ0=2PF
TT=1US)
* Subcircuit ASCR, which is missing, must be inserted.
ANALYSIS ■■■ .TRAN 10US 33.33MS 0 0.1MS ; Transient analysis
.PROBE ; Graphics post-processor
.OPTIONS ABSTOL = 1.00N RELTOL = 0.01 VNTOL = 0.01
ITL5 = 10000 ;
* Convergence
.FOUR 60HZ I(VX)
.END

```

---

Note the following:

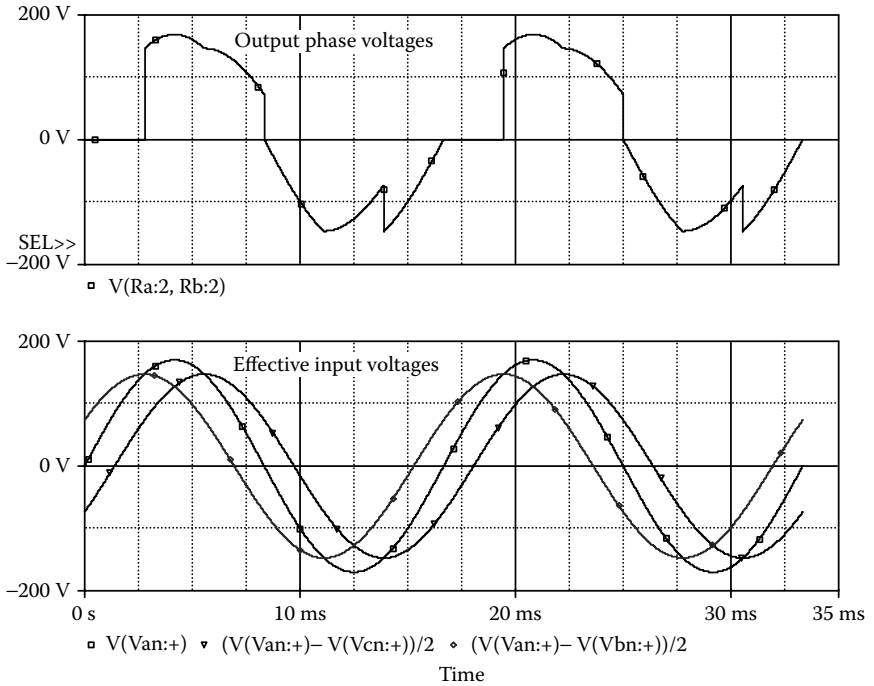
- (a) The PSpice plots of the instantaneous output voltage  $V(4,11)$  are shown in [Figure 12.7](#).
- (b) The Fourier series of the input current is as follows:

**FOURIER COMPONENTS OF TRANSIENT RESPONSE I(VX)**

DC COMPONENT = -1.573343E-02

Harmonic No	Frequency (Hz)	Fourier Component	Normalized Component	Phase (Deg)	Normalized Phase (Deg)
1	6.000E+01	5.881E+01	1.000E+00	-1.195E+01	0.000E+00
2	1.200E+02	1.423E+01	2.419E-01	-1.695E+02	-1.576E+02
3	1.800E+02	3.855E-02	6.555E-04	8.972E+01	1.017E+02
4	2.400E+02	9.580E+00	1.629E-01	1.064E+02	1.184E+02
5	3.000E+02	6.952E+00	1.182E-01	5.972E+01	7.167E+01
6	3.600E+02	3.150E-02	5.356E-04	-9.084E+01	-7.889E+01
7	4.200E+02	3.487E+00	5.930E-02	-6.156E+01	-4.961E+01
8	4.800E+02	3.140E+00	5.339E-02	-1.305E+02	-1.185E+02
9	5.400E+02	3.854E-02	6.554E-04	8.912E+01	1.011E+02

TOTAL HARMONIC DISTORTION = 3.246548E+01 PERCENT



**FIGURE 12.7** Plots for Example 12.2 for a delay angle of  $\alpha = 60^\circ$ .

Total harmonic distortion of input current THD = 32.47% = 0.3247  
 Displacement angle  $\phi_1 = -11.95^\circ$   
 Displacement factor DF =  $\cos \phi_1 = \cos(-11.95) = 9.783$  (lagging)

From Equation 7.3, the input power factor is

$$PF = \frac{1}{(1 + THD^2)^{1/2}} \cos \phi_1 = \frac{1}{(1 + 0.3247^2)^{1/2}} \times 0.9783 = 0.93 \text{ (lagging)}$$

*Note:* The instantaneous output voltage depends on the instantaneous effective input voltages as shown in Figure 12.7.

### EXAMPLE 12.3 FINDING THE PERFORMANCE OF A THREE-PHASE FULL-WAVE AC VOLTAGE CONTROLLER

A three-phase full-wave AC voltage controller is supplied from a wye-connected supply as shown in Figure 12.8(a). The input phase voltage has a peak of 169.7 V, 60 Hz. The load resistance per phase is  $R = 2.5 \Omega$ . The delay angle is  $\alpha = 60^\circ$ . The gate voltages are shown in Figure 12.8(b). Use PSpice to (a) plot the instantaneous output phase voltage  $v_o$  and (b) calculate the Fourier coefficients of the input current  $i_a$  and the input power factor  $PF$ .

#### SOLUTION

The peak supply voltage per phase  $V_m = 169.7$  V. For  $\alpha_1 = 60^\circ$ ,

$$\text{time delay } t_1 = \frac{60}{360} \times \frac{1000}{60 \text{ Hz}} \times 1000 = 2777.78 \mu\text{sec}$$

$$\text{time delay } t_3 = \frac{180}{360} \times \frac{1000}{60 \text{ Hz}} \times 1000 = 8333.3 \mu\text{sec}$$

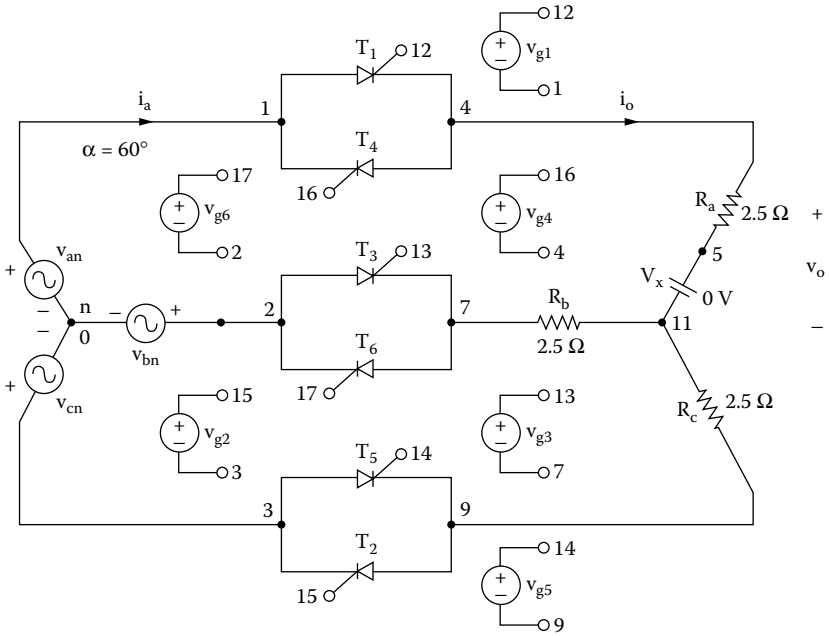
$$\text{time delay } t_5 = \frac{300}{360} \times \frac{1000}{60 \text{ Hz}} \times 1000 = 13,888.9 \mu\text{sec}$$

$$\text{time delay } t_2 = \frac{120}{360} \times \frac{1000}{60 \text{ Hz}} \times 1000 = 5555.78 \mu\text{sec}$$

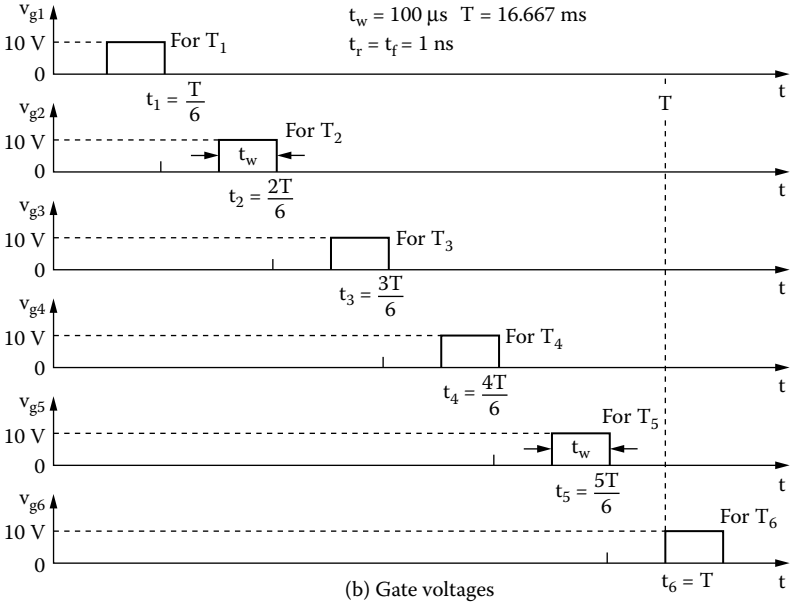
$$\text{time delay } t_4 = \frac{240}{360} \times \frac{1000}{60 \text{ Hz}} \times 1000 = 11,111.1 \mu\text{sec}$$

$$\text{time delay } t_6 = \frac{360}{360} \times \frac{1000}{60 \text{ Hz}} \times 1000 = 16,666.7 \mu\text{sec}$$

The PSpice schematic with SCRs is shown in Figure 12.9. The model name of the SCR, 2N1595, is changed to ASCR, whose subcircuit definition is listed in Section 12.2. By varying the delay cycle  $\alpha$ , the output voltage can be changed. The supply frequency {FREQ} and the duty cycle {DELAY\_ANGLE} are defined as variables.



(a) Circuit



(b) Gate voltages

**FIGURE 12.8** Three-phase full-wave AC controller for PSpice simulation. (a) Circuit, (b) gate voltages.

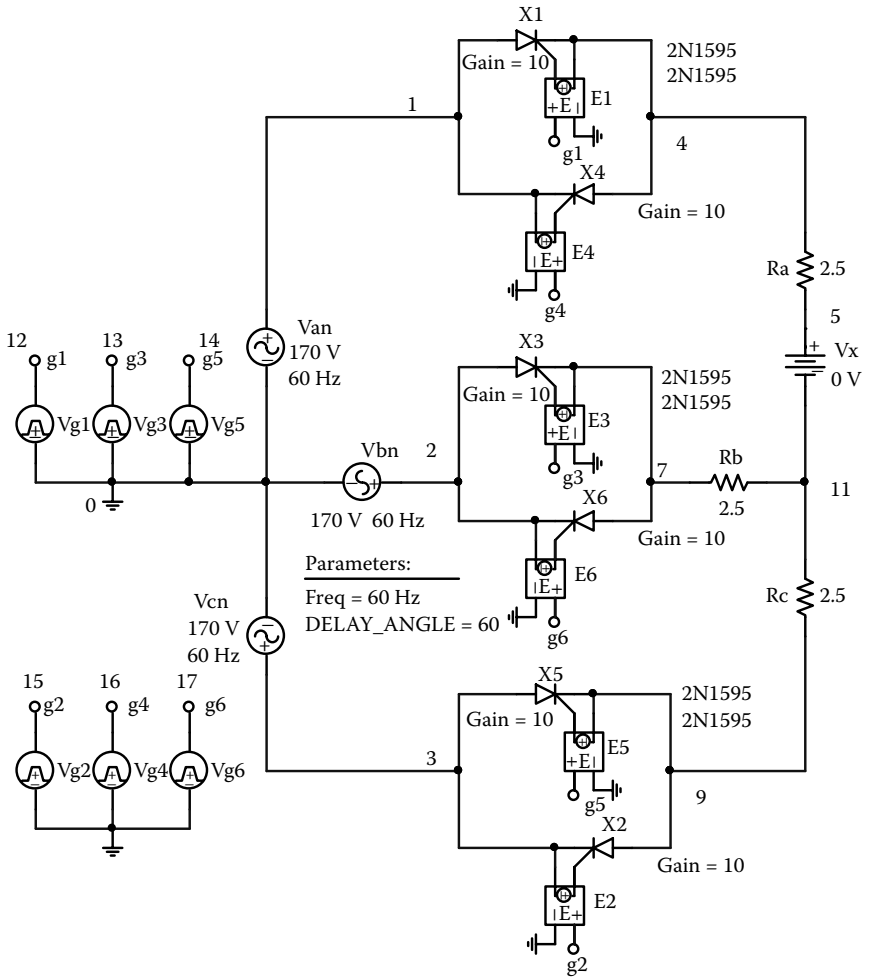


FIGURE 12.9 PSpice schematic for Example 12.3.

The listing of the circuit file is as follows:

### Example 12.3 Three-phase full-wave AC voltage controller

```

SOURCE ■ Van 1 0 SIN (0 169.7V 60HZ)
        Vbn 2 0 SIN (0 169.7V 60HZ 0 0 -120DEG)
        Vcn 3 0 SIN (0 169.7V 60HZ 0 0 -240DEG)
        .PARAM DELAY_ANGLE=60 FREQ=60HZ
        Vg1 12 4 PULSE (0 10 {{Delay_Angle}}/{360*{FREQ}}) 1ns 1ns
        100us {1/{FREQ}})
    
```

```

Vg2 13 7 PULSE (0 10 {{{Delay_Angle}+60}/{360*{Freq}}})
1ns 1ns 100us {1/{Freq}})
Vg3 14 9 PULSE (0 10 {{{Delay_Angle}+120}/{360*{Freq}}})
1ns 1ns 100us {1/{Freq}})
Vg4 15 3 PULSE (0 10 {{{Delay_Angle}+180}/{360*{Freq}}})
1ns 1ns 100us {1/{Freq}})
Vg5 16 1 PULSE (0 10 {{{Delay_Angle}+240}/{360*{Freq}}})
1ns 1ns 100us {1/{Freq}})
Vg6 17 2 PULSE (0 10 {{{Delay_Angle}+300}/{360*{Freq}}})
1ns 1ns 100us {1/{Freq}})

```

```

CIRCUIT ■■ Ra 4 5 2.5
VX 5 11 DC 0V ; To measure load current
Rb 7 11 2.5
Rc 9 11 2.5
* Subcircuit calls for thyristor model:
XT1 1 4 12 4 ASCR ; Thyristor T1
XT3 2 7 13 7 ASCR ; Thyristor T3
XT5 3 9 14 9 ASCR ; Thyristor T5
XT2 9 3 15 3 ASCR ; Thyristor T2
XT4 4 1 16 1 ASCR ; Thyristor T4
XT6 7 2 17 2 ASCR ; Thyristor T6
* Subcircuit ASCR, which is missing, must be inserted.
ANALYSIS ■■■ .TRAN 0.1MS 33.33MS ; Transient analysis
.PROBE ; Graphics post-processor
.OPTIONS ABSTOL = 1.00N RELTOL = 0.01 VNTOL = 0.01 ITL5
= 10000 ;
* Convergence
.FOUR 60HZ I(VX)
.END

```

Note the following:

- The PSpice plots of instantaneous output phase voltage V(4,11) and input voltages are shown in [Figure 12.10](#).
- The Fourier series of the input phase current is as follows:

---

### FOURIER COMPONENTS OF TRANSIENT RESPONSE I(VX)

DC COMPONENT = 3.465652E-05

Harmonic No	Frequency (Hz)	Fourier Component	Normalized Component	Phase (Deg)	Normalized Phase (Deg)
1	6.000E+01	5.354E+01	1.000E+00	-2.701E+01	0.000E+00
2	1.200E+02	6.775E-05	1.266E-06	9.195E+01	1.190E+02
3	1.800E+02	6.944E-02	1.297E-03	8.967E+01	1.167E+02

4	2.400E+02	6.785E-05	1.267E-06	8.835E+01	1.154E+02
5	3.000E+02	1.396E+01	2.608E-01	5.936E+01	8.637E+01
6	3.600E+02	6.873E-05	1.284E-06	8.983E+01	1.168E+02
7	4.200E+02	7.005E+00	1.308E-01	-6.106E+01	-3.404E+01
8	4.800E+02	6.862E-05	1.282E-06	9.200E+01	1.190E+02
9	5.400E+02	6.945E-02	1.297E-03	8.901E+01	1.160E+02

TOTAL HARMONIC DISTORTION = 2.917517E+01 PERCENT

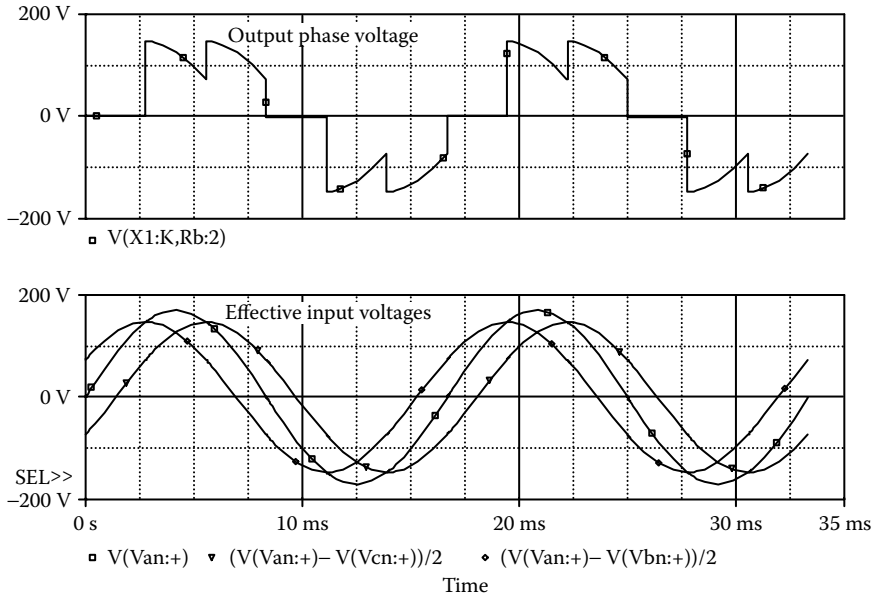


FIGURE 12.10 Plots for Example 12.3 for a delay angle of  $\alpha = 60^\circ$ .

Total harmonic distortion of input current THD = 29.18% = 0.2918

Displacement angle  $\phi_1 = -27.01^\circ$

Displacement factor DF =  $\cos \phi_1 = \cos(-27.01) = 0.891$  (lagging)

From Equation 7.3, the input power factor is

$$PF = \frac{1}{(1 + THD^2)^{1/2}} \cos \phi_1 = \frac{1}{(1 + 0.2918^2)^{1/2}} \times 0.891 = 0.855 \text{ (lagging)}$$

Note: However, the input power factor of the full-wave controller is lower than that of the half-wave controller for the same delay angle  $\alpha = 60^\circ$ .

### EXAMPLE 12.4 FINDING THE PERFORMANCE OF A THREE-PHASE FULL-WAVE DELTA-CONNECTED CONTROLLER

A three-phase full-wave delta-connected controller is supplied from a wye-connected three-phase supply as shown in Figure 12.11(a). The input phase voltage has a peak of 169.7 V, 60 Hz. The load resistance per phase is  $R = 2.5 \Omega$ . The delay angle is  $\alpha = 60^\circ$ . The gate voltages are shown in Figure 12.11(b). Use PSpice to (a) plot the instantaneous output phase voltage  $v_o$  and the input line current  $i_a$  and (b) calculate the Fourier coefficients of the output phase current  $i_o$ .

#### SOLUTION

The PSpice schematic with SCRs is shown in Figure 12.12. The model name of the SCR, 2N1595, is changed to ASCR, whose subcircuit definition is listed in Section 12.2. By varying the delay cycle  $\alpha$ , the output voltage can be changed. The supply frequency {FREQ} and the duty cycle {DELAY\_ANGLE} are defined as variables.

The delay angles are the same as Example 12.3. The listing of the circuit file is as follows:

---

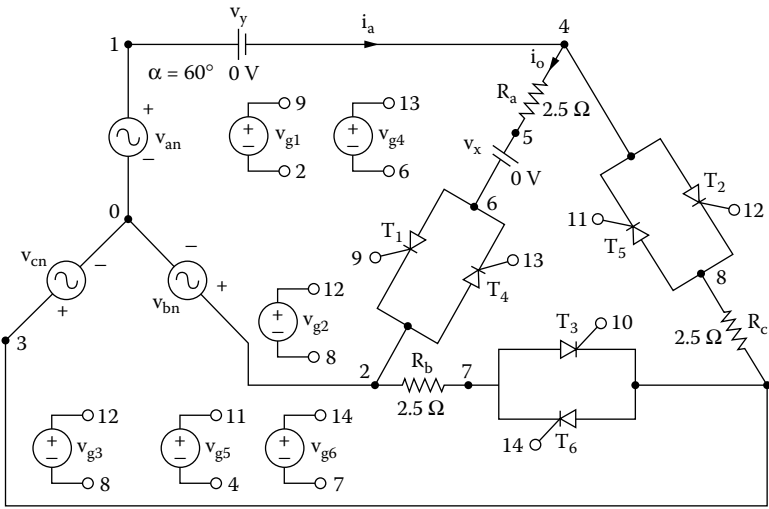
### Example 12.4 Three-phase full-wave delta-connected AC controller

```

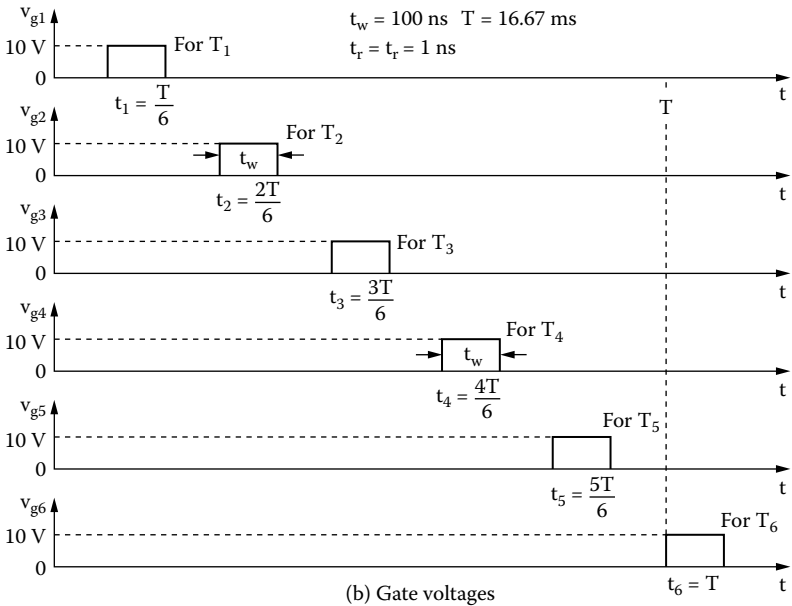
SOURCE  ■ Van  1 0 SIN (0 169.7V 60HZ)
        Vbn  2 0 SIN (0 169.7V 60HZ 0 0 -120DEG)
        Vcn  3 0 SIN (0 169.7V 60HZ 0 0 -240DEG)
        .PARAM Freq=60Hz Delay_Angle=90
        Vg1  9 2 PULSE (0 10 {{Delay_Angle}}/{360*{Freq}}) 1ns 1ns
            100us {1/{Freq}})
        Vg2  12 8 PULSE (0 10 {{{Delay_Angle}+60}}/{360*{Freq}})
            1ns 1ns 100us {1/{Freq}})
        Vg3  10 3 PULSE (0 10 {{{Delay_Angle}+120}}/{360*{Freq}})
            1ns 1ns 100us {1/{Freq}})
        Vg4  13 6 PULSE (0 10 {{{Delay_Angle}+180}}/{360*{Freq}})
            1ns 1ns 100us {1/{Freq}})
        Vg5  11 4 PULSE (0 10 {{{Delay_Angle}+240}}/{360*{Freq}})
            1ns 1ns 100us {1/{Freq}})
        Vg6  14 7 PULSE (0 10 {{{Delay_Angle}+300}}/{360*{Freq}})
            1ns 1ns 100us {1/{Freq}})
        Ra  4 5 2.5
        VX  5 6 DC 0V ; Load current ammeter
        Rb  2 7 2.5
        Rc  3 8 2.5
        VY  1 4 DC 0V ; Line current ammeter

```





(a) Circuit



(b) Gate voltages

**FIGURE 12.11** Three-phase full-wave delta-connected controller for PSpice simulation. (a) Circuit, (b) gate voltages.

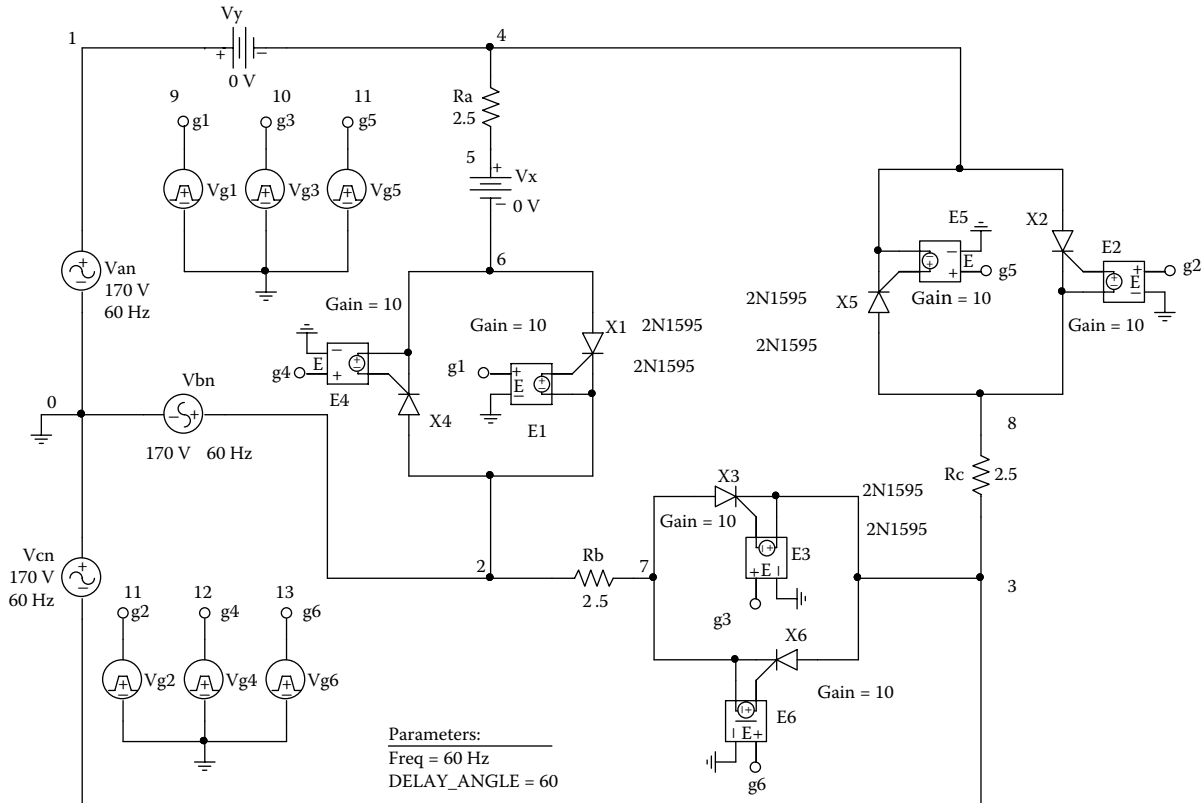


FIGURE 12.12 PSpice schematic for Example 12.4.

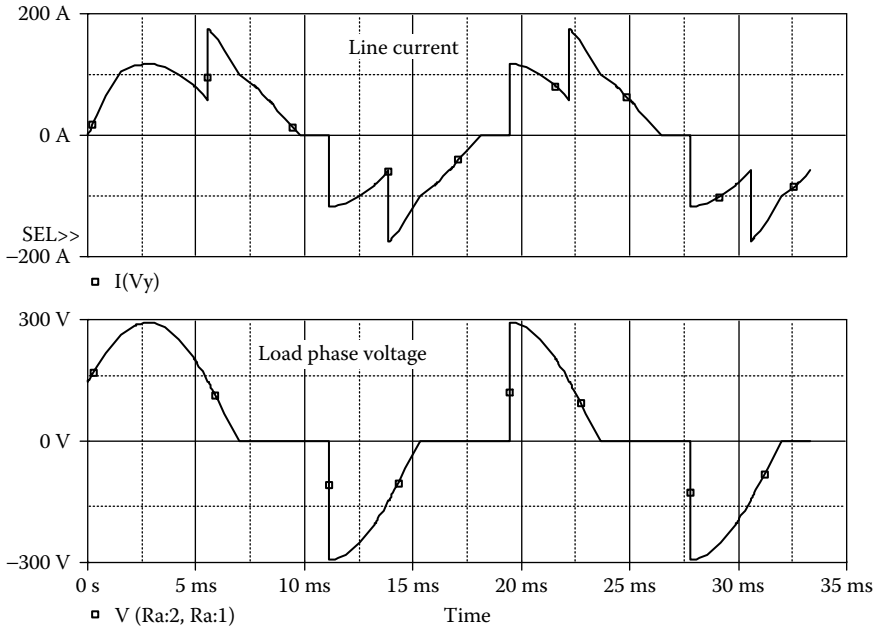


FIGURE 12.13 Plots for Example 12.4 for a delay angle of  $\alpha = 60^\circ$ .

**EXAMPLE 12.5 FINDING THE PERFORMANCE OF A THREE-PHASE THREE-THYRISTOR DELTA-CONNECTED CONTROLLER**

A three-phase three-thyristor controller is supplied from a three-phase wye-connected supply as shown in Figure 12.14(a). The input phase voltage has a peak of 169.7 V, 60 Hz. The load resistance per phase is  $R = 2.5 \Omega$ . The delay angle is  $\alpha = 30^\circ$ . The gate voltages are shown in Figure 12.14(b). Use PSpice to (a) plot the instantaneous line current  $i_a$  and thyristor  $T_1$  current  $i_{T1}$  and (b) calculate the Fourier coefficients of the line current  $i_a$ .

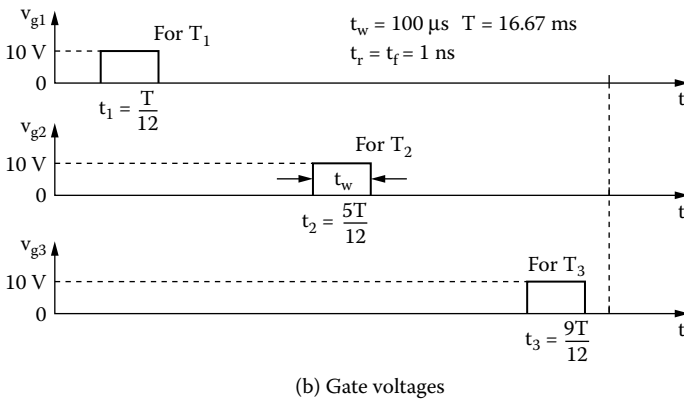
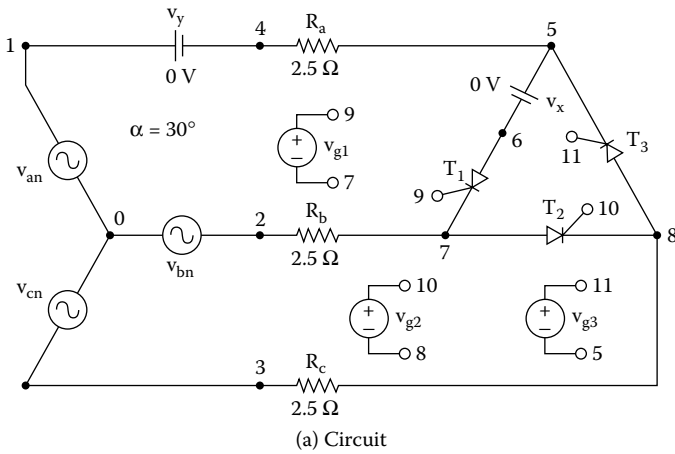
**SOLUTION**

The peak supply voltage per phase  $V_m = 169.7$  V. For  $\alpha = 90^\circ$ ,

$$\text{time delay } t_1 = \frac{30}{360} \times \frac{1000}{60 \text{ Hz}} \times 1000 = 1388.9 \mu\text{sec}$$

$$\text{time delay } t_2 = \frac{150}{360} \times \frac{1000}{60 \text{ Hz}} \times 1000 = 6944.5 \mu\text{sec}$$

$$\text{time delay } t_3 = \frac{270}{360} \times \frac{1000}{60 \text{ Hz}} \times 1000 = 12,500 \mu\text{sec}$$



**FIGURE 12.14** Three-phase three-thyristor controller for PSpice simulation. (a) Circuit, (b) gate voltages.

The PSpice schematic with SCRs is shown in [Figure 12.15](#). The model name of the SCR, 2N1595, is changed to ASCR, whose subcircuit definition is listed in Section 12.2. By varying the delay cycle  $\alpha$ , the output voltage can be changed. The supply frequency {FREQ} and the duty cycle {DELAY\_ANGLE} are defined as variables.

The listing of the circuit file is as follows:

**Example 12.5 Three-phase three-thyristor AC controller**

```

SOURCE ■ Van 1 0 SIN (0 169.7V 60HZ)
        Vbn 2 0 SIN (0 169.7V 60HZ 0 0 -120DEG)
        Vcn 3 0 SIN (0 169.7V 60HZ 0 0 -240DEG)
        .PARAM DELAY_ANGLE=30 FREQ=60HZ
    
```

```
Vg1 9 7 PULSE (0 10 {{Delay_Angle}}/{360*{Freq}}) 1ns 1ns
100us {1/{Freq}})
Vg2 10 8 PULSE (0 10 {{Delay_Angle}+120}}/{360*{Freq}})
1ns1ns 100us {1/{Freq}})
Vg3 11 5 PULSE (0 10 {{Delay_Angle}+240}}/{360*{Freq}})
1ns 1ns 100us {1/{Freq}})
```

```
CIRCUIT ■■ Ra 4 5 2.5
VX 5 6 DC 0V ; Load current ammeter
Rb 2 7 2.5
Rc 3 8 2.5
VY 1 4 DC 0V ; Line current ammeter
* Subcircuit calls for thyristor model:
XT1 6 7 9 7 ASCR ; Thyristor T1
XT2 7 8 10 8 ASCR ; Thyristor T3
XT3 8 5 11 5 ASCR ; Thyristor T5
* Subcircuit ASCR, which is missing, must be inserted.

ANALYSIS ■■■ .TRAN 1US 33.33MS 00.1MS ; Transient analysis
.PROBE ; Graphics post-processor
.OPTIONS ABSTOL = 1.00N RELTOL = 0.01 VNTOL = 0.01
ITL5 = 10000
.FOUR 60HZ I(VX)
.END
```

Note the following:

- (a) The PSpice plots of the instantaneous line current  $I(VY)$  and phase voltage  $V(6, 7)$  are shown in [Figure 12.16](#).
- (b) The Fourier coefficients of the thyristor  $T_1$  current are:

---

## FOURIER COMPONENTS OF TRANSIENT RESPONSE I(VX)

DC COMPONENT = 1.614633E+01

Harmonic No	Frequency (Hz)	Fourier Component	Normalized Component	Phase (Deg)	Normalized Phase (Deg)
1	6.000E+01	2.614E+01	1.000E+00	8.992E+00	0.000E+00
2	1.200E+02	1.393E+01	5.328E-01	5.685E+01	-6.584E+01
3	1.800E+02	8.074E+00	3.089E-01	-9.054E+01	-9.953E+01
4	2.400E+02	5.129E+00	1.962E-01	-1.365E+02	-1.455E+02
5	3.000E+02	3.097E+00	1.185E-01	-1.210E+02	-1.300E+02
6	3.600E+02	5.598E+00	2.142E-01	-1.713E+02	-1.803E+02
7	4.200E+02	3.119E+00	1.193E-01	1.192E+02	1.102E+02
8	4.800E+02	2.366E+00	9.053E-02	1.559E+02	1.469E+02
9	5.400E+02	4.030E+00	1.542E-01	8.903E+01	8.004E+01

TOTAL HARMONIC DISTORTION = 7.237835E+01 PERCENT

---

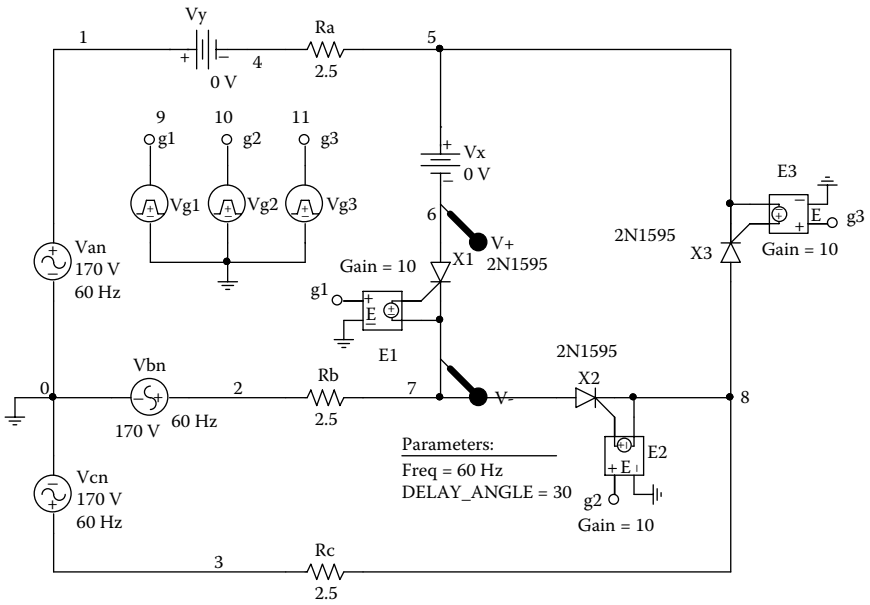


FIGURE 12.15 PSpice schematic for Example 12.5.

**EXAMPLE 12.6 FINDING THE PERFORMANCE OF A SINGLE-PHASE AC VOLTAGE CONTROLLER WITH AN OUTPUT FILTER**

A capacitor of 780  $\mu\text{F}$  is connected across the output of the single-phase full-wave controller of Figure 12.2(a). This is shown in Figure 12.17(a). The input voltage has a peak of 169.7 V, 60 Hz. The load inductance  $L$  is 6.5 mH, and the load resistance is  $R = 2.5 \Omega$ . The delay angles are equal:  $\alpha_1 = \alpha_2 = 60^\circ$ . The gate voltages are shown in Figure 12.17(b). Use PSpice to (a) plot the instantaneous output voltage  $v_o$  and the load current  $i_o$  and (b) calculate the Fourier coefficients of the input current  $i_a$  and the input power factor  $PF$ .

**SOLUTION**

The peak supply voltage  $V_m = 169.7 \text{ V}$ . For  $\alpha_1 = \alpha_2 = 60^\circ$ , the time delay  $t_1 = (60/360) \times 1000/60 \text{ Hz} \times 1000 = 2,777.7 \mu\text{sec}$ . A series snubber with  $C_s = 0.1 \mu\text{F}$  and  $R_s = 750 \Omega$  is connected across the thyristor to cope with the transient voltage due to the inductive load. The PSpice schematic with SCRs is shown in Figure 12.18. The model name of the SCR, 2N1595, is changed to ASCR, whose subcircuit definition is listed in Section 12.2. By varying the delay cycle  $\alpha$ , the output voltage can be varied. The supply frequency {FREQ} and the duty cycle {DELAY\_ANGLE} are defined as variables.

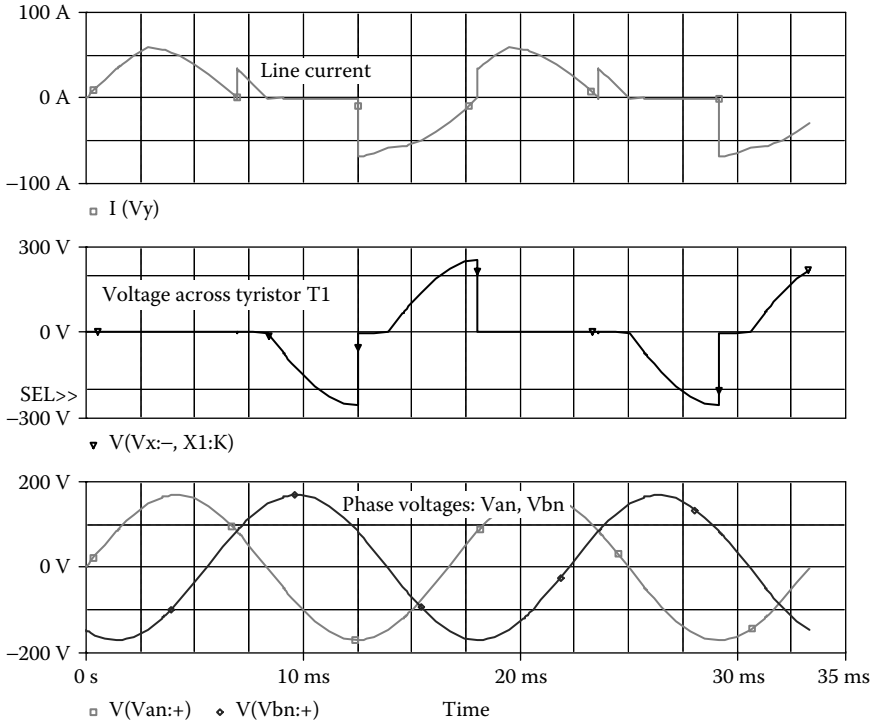


FIGURE 12.16 Plots for Example 12.5 for a delay angle of  $\alpha = 30^\circ$ .

The listing of the circuit file is as follows:

### Example 12.6 Single-phase AC voltage controller with output filter

```

SOURCE ■ VS 1 0 SIN (0 169.7V 60HZ)
        .PARAM DELAY_ANGLE=60 FREQ=60Hz
Vg1 2 4 PULSE (0 10 {{Delay_Angle}}/{360*{FREQ}} 1ns 1ns
100us {1/{FREQ}})
Vg2 3 1 PULSE (0 10 {{(Delay_Angle)+180}}/{360*{FREQ}})
1ns 1ns 100us {1/{FREQ}})
CIRCUIT ■ R 4 5 2.5
L 5 6 6.5MH
VX 6 0 DC 0V ; Voltage source to measure the load current
C 4 0 780UF ; Output filter capacitance
CS 1 7 0.1UF
RS 7 4 750

```

\* Subcircuit calls for thyristor model:

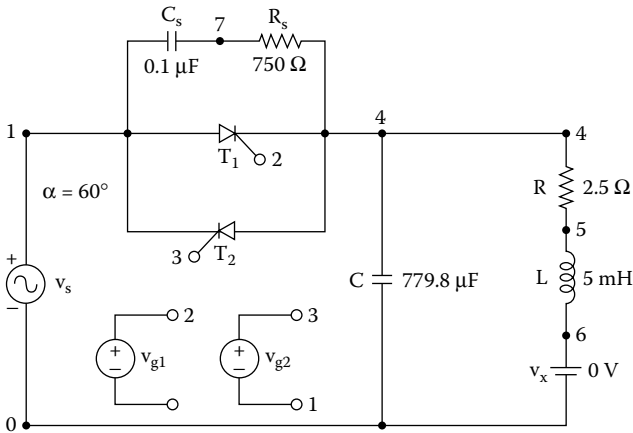
XT1 1 4 2 4 ASCR ; Thyristor T1

XT2 4 1 3 1 ASCR ; Thyristor T2

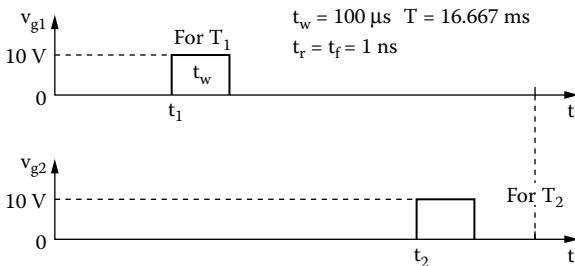
\* Subcircuit ASCR, which is missing, must be inserted.

```

ANALYSIS ■■■ .TRAN 1US 33.33MS ; Transient analysis
                .PROBE ;Graphics post-processor
                .OPTIONS ABSTOL = 1.00N RELTOL = 1.0M VNTOL = 1.0M
                ITL5 = 10000
                .FOUR 60HZ I(VX) ;Fourier analysis
                .END
    
```



(a) Circuit



(b) Gate voltages

**FIGURE 12.17** Single-phase full-wave AC controller for PSpice simulation. (a) Circuit, (b) gate voltages.

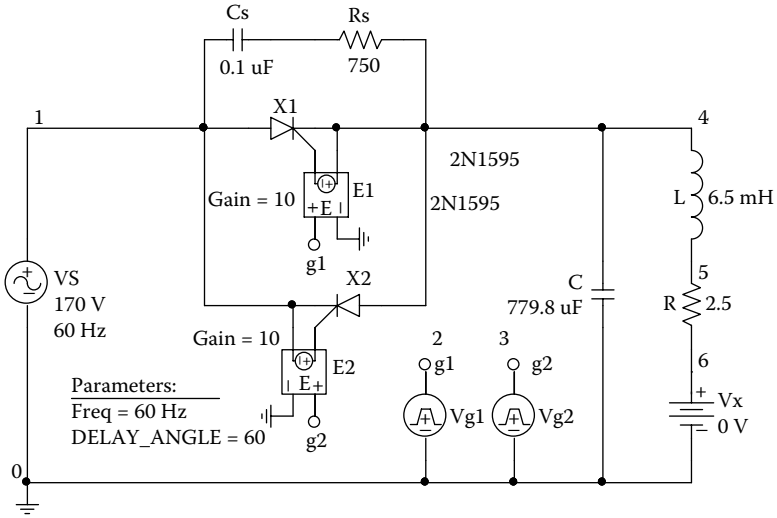


FIGURE 12.18 PSpice schematic for Example 12.6.

Note the following:

- (a) The PSpice plots of instantaneous output voltage  $V(4)$  and load current  $I(VX)$  are shown in Figure 12.19.
- (b) The Fourier series of the input current is as follows:

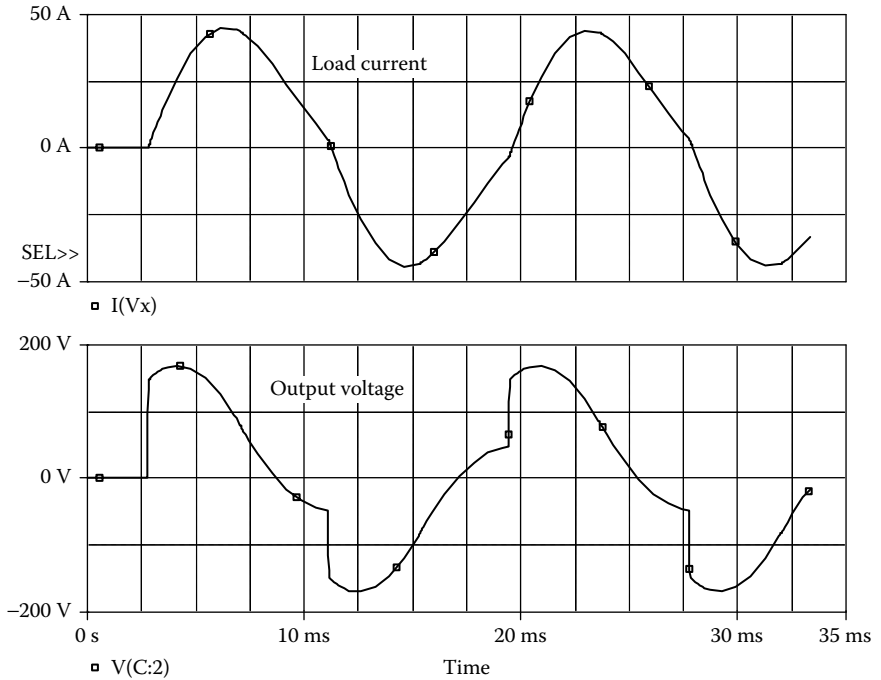
**FOURIER COMPONENTS OF TRANSIENT RESPONSE  $I(VX)$**

DC COMPONENT =  $-1.681664E-02$

Harmonic No	Frequency (Hz)	Fourier Component	Normalized Component	Phase (Deg)	Normalized Phase (Deg)
1	6.000E+01	3.314E+01	1.000E+00	-6.980E+01	0.000E+00
2	1.200E+02	1.606E-02	4.845E-04	1.053E+02	1.751E+02
3	1.800E+02	4.381E+00	1.322E-01	1.816E+01	8.795E+01
4	2.400E+02	4.887E-03	1.475E-04	4.289E+01	1.127E+02
5	3.000E+02	1.404E+00	4.238E-02	-1.722E+02	-1.024E+02
6	3.600E+02	2.921E-03	8.815E-05	4.669E+01	1.165E+02
7	4.200E+02	7.014E-01	2.116E-02	5.241E+00	7.504E+01
8	4.800E+02	1.879E-03	5.670E-05	2.298E+01	9.278E+01
9	5.400E+02	4.193E-01	1.265E-02	-1.764E+02	-1.066E+02

TOTAL HARMONIC DISTORTION = 1.410080E+01 PERCENT

Total harmonic distortion of input current  $THD = 14.1\% = 0.141$   
 Displacement angle  $\phi_1 = -69.88^\circ$   
 Displacement factor  $DF = \cos \phi_1 = \cos(-69.88) = 0.344$  (lagging)



**FIGURE 12.19** Plots for Example 12.6 for delay angle  $\alpha = 60^\circ$ .

From Equation 7.3, the input power factor is

$$PF = \frac{1}{(1 + THD^2)^{1/2}} \cos \phi_1 = \frac{1}{(1 + 0.141^2)^{1/2}} \times 0.344 = 0.341 \text{ (lagging)}$$

## 12.5 LABORATORY EXPERIMENTS

The following two experiments are suggested to demonstrate the operation and characteristics of thyristor AC controllers:

- Single-phase AC voltage controller
- Three-phase AC voltage controller

### 12.5.1 EXPERIMENT AC.1

#### Single-Phase AC Voltage Controller

- Objective** To study the operation and characteristics of a single-phase AC voltage controller under various load conditions.
- Applications** The single-phase AC voltage controller is used to control power flow in industrial and induction heating, pumps and fans, light dimmers, food blenders, etc.

**Textbook**

See [Reference 2](#), Section 11.4 and Section 11.5.

**Apparatus**

1. Two phase-controlled thyristors with ratings of at least 50 A and 400 V, mounted on heat sinks
2. A firing pulse generator with isolating signals for gating thyristors
3. An  $RL$  load
4. One dual-beam oscilloscope with floating or isolating probes
5. AC voltmeters and ammeters and one noninductive shunt

**Warning**

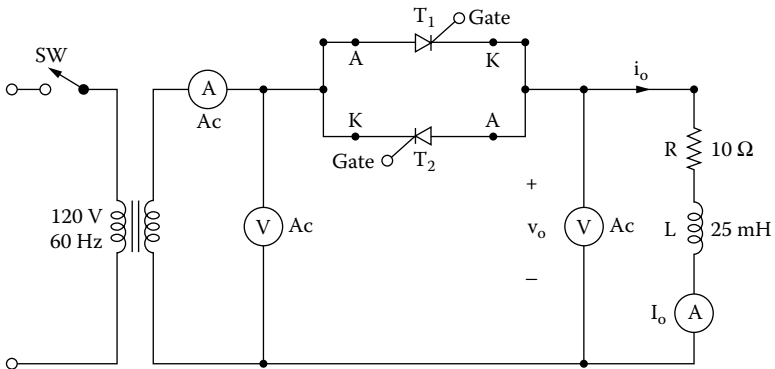
Before making any circuit connection, switch off the AC power. Do not switch on the power unless the circuit is checked and approved by your laboratory instructor. Do not touch the thyristor heat sinks, which are connected to live terminals.

**Experimental procedure**

1. Set up the circuit as shown in Figure 12.20. Use a load resistance  $R$  only.
2. Connect the measuring instruments as required.
3. Set the delay angle to  $\alpha = \pi/3$ .
4. Connect the firing pulses to appropriate thyristors.
5. Observe and record the waveforms of the load voltage  $v_o$  and the load current  $i_o$ .
6. Measure the rms load voltage  $V_{o(rms)}$ , the rms load current  $I_{o(rms)}$ , the average thyristor current  $I_{T(rms)}$ , the rms input voltage  $V_{s(rms)}$ , and the load power  $P_L$ .
7. Measure the conduction angle of thyristor  $T_1$ .
8. Repeat steps 2 to 7 with a load inductance  $L$  only.
9. Repeat steps 2 to 7 with both load resistance  $R$  and load inductance  $L$ .

**Report**

1. Present all recorded waveforms and discuss all significant points.
2. Compare the waveforms generated by SPICE with the experimental results, and comment.
3. Compare the experimental results with the predicted results.
4. Calculate and plot the rms output voltage  $V_o$  against the delay angle  $\alpha$ .
5. Discuss the advantages and disadvantages of this type of controller.



**FIGURE 12.20** Single-phase AC voltage controller.

## 12.5.2 EXPERIMENT AC.2

### Three-Phase AC Voltage Controller

**Objective** To study the operation and characteristics of a three-phase AC voltage controller under various load conditions.

**Applications** The three-phase controller is used to control power flow in industrial and induction heating, lighting, speed control of induction motor-driven pumps and fans, etc.

**Textbook** See Reference 2, Section 11.6.

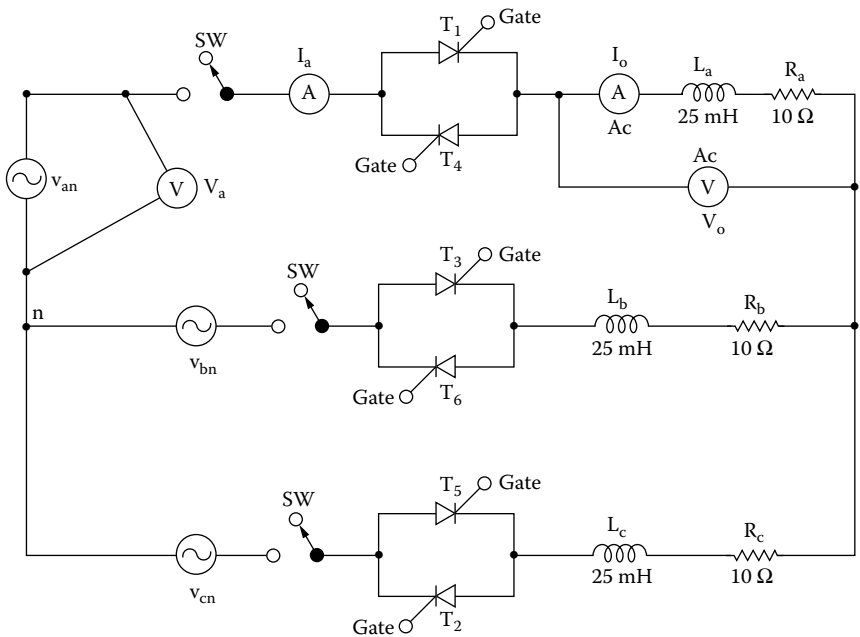
**Apparatus**

1. Six phase-controlled thyristors with ratings of at least 50 A and 400 V, mounted on heat sinks
2. A firing pulse generator with isolating signals for gating thyristors
3.  $RL$  loads
4. One dual-beam oscilloscope with floating or isolating probes
5. AC voltmeters and ammeters and one noninductive shunt

**Warning** See Experiment AC.1.

**Experimental procedure** Repeat the steps of Experiment AC.1 for the circuit of Figure 12.21.

**Report** See Experiment AC.1.



**FIGURE 12.21** Three-phase AC voltage controller.

## 12.6 SUMMARY

The statements for an AC thyristor are:

\* Subcircuit call for switched AC thyristor model:

XT1	NA	NC	+NC	-NC	ASCR
	anode	cathode	+control	-control	model
*			voltage	voltage	name

## SUGGESTED READING

1. L.J. Giacoletto, Simple SCR and TRAIC PSPICE computer models, *IEEE Transactions on Industrial Electronics*, Vol. 36, No. 3, August 1989, pp. 451–455.
2. M.H. Rashid, *Power Electronics: Circuits, Devices, and Applications*, 2nd ed., Englewood Cliffs, NJ: Prentice Hall, 1993, chap. 6.

## DESIGN PROBLEMS

### 12.1

It is required to design the single-phase AC voltage controller of [Figure 12.20](#) with the following specifications:

AC supply voltage  $V_s = 120$  V (rms), 60 Hz

Load resistance  $R = 5 \Omega$

Load inductance  $L = 15$  mH

Rms output voltage  $V_{o(\text{rms})} = 75\%$  of the maximum value

- (a) Determine the ratings of all devices under worst-case conditions.
- (b) Use SPICE to verify your design.
- (c) Provide a cost estimate of the circuit.

### 12.2

- (a) Design an output  $C$  filter for the single-phase full-wave AC voltage controller of Problem 12.1. The harmonic content of the load current should be less than 10% of the value without the filter.
- (b) Use SPICE to verify your design in part (a).

### 12.3

It is required to design the three-phase AC voltage controller of [Figure 12.21](#) with the following specifications:

AC supply voltage per phase  $V_s = 120$  V (rms), 60 Hz

Load resistance per phase,  $R = 5 \Omega$

Load inductance per phase,  $L = 15$  mH

Rms output voltage  $V_{o(\text{rms})} = 75\%$  of the maximum value

- Determine the ratings of all devices under worst-case conditions.
- Use SPICE to verify your design.
- Provide a cost estimate of the circuit.

## 12.4

- Design an output  $C$  filter for the three-phase AC voltage controller of Problem 12.3. The harmonic content of the load current should be less than 10% of the value without the filter.
- Use SPICE to verify your design in part (a).

## 12.5

Use PSpice to find the worst-case minimum and maximum output voltages  $V_{o(\text{max})}$  and  $V_{o(\text{min})}$  for Problem 12.1. Assume uniform tolerances of  $\pm 15\%$  for all passive elements and an operating temperature of  $25^\circ\text{C}$ .

## 12.6

Use PSpice to find the worst-case minimum and maximum output voltages  $V_{o(\text{max})}$  and  $V_{o(\text{min})}$  for Problem 12.2. Assume uniform tolerances of  $\pm 15\%$  for all passive elements and an operating temperature of  $25^\circ\text{C}$ .

## 12.7

Use PSpice to find the worst-case minimum and maximum output voltages  $V_{o(\text{max})}$  and  $V_{o(\text{min})}$  for Problem 12.3. Assume uniform tolerances of  $\pm 15\%$  for all passive elements and an operating temperature of  $25^\circ\text{C}$ .

## 12.8

Use PSpice to find the worst-case minimum and maximum output voltages  $V_{o(\text{max})}$  and  $V_{o(\text{min})}$  for Problem 12.4. Assume uniform tolerances of  $\pm 15\%$  for all passive elements and an operating temperature of  $25^\circ\text{C}$ .

---

# 13 Control Applications

The learning objectives of this chapter are:

- Modeling operational amplifier (op-amp) circuits for control applications and specifying their mode parameters
- Designing analog behavioral models (ABMs) for signal conditioning applications
- Performing analog simulations and analog behavioral modeling of control systems
- Performing transient analysis of control systems
- Performing worst-case analysis of AC voltage controllers for parametric variations of model parameters and tolerances

## 13.1 INTRODUCTION

In practical applications, power converters are normally operated under closed-loop control, which requires comparing the desired output with the actual output. The control implementation requires summing, differentiating, and integrating signals to obtain the desired control strategy. SPICE can be used in modeling:

- Op-amp circuits
- Control systems
- Signal conditioning

## 13.2 OP-AMP CIRCUITS

An op-amp may be modeled as a linear amplifier to simplify the design and analysis of op-amp circuits. The linear models give reasonable results, especially for determining the approximate design values of op-amp circuits. The simulation of the actual behavior of op-amps is required in many applications to obtain accurate response of electronic circuits. An op-amp can be simulated from the circuit arrangement of the particular type of op-amp. The  $\mu 741$  type of op-amp consists of 24 transistors and is beyond the capability of the student (or demo) version of PSpice. However, a macromodel, which is a simplified version of the op-amp and requires only two transistors, is quite accurate for many applications and can be simulated as a subcircuit or library file. Some op-amp manufacturers supply macromodels of their op-amps [1]. In the absence of a complex op-amp model, the characteristics of op-amp circuits may be represented approximately by one of the following models:

- DC linear models
- AC linear models
- Nonlinear macromodels

### 13.2.1 DC LINEAR MODELS

An op-amp may be modeled as a voltage-controlled voltage source, as shown in Figure 13.1(a). The input resistance is high, typically 2 MΩ, and the output resistance is very low, typically 75 Ω. For an ideal op-amp, the model of Figure 13.1(a) can be reduced to Figure 13.1(b). These models do not take into account the saturation effect and slew rate that exist in practical op-amps. The voltage gain is also assumed to be independent of the frequency, but in practical op-amps the gain falls with the frequency. These simple models are normally suitable for DC or low-frequency applications.

### 13.2.2 AC LINEAR MODELS

The frequency response of an op-amp can be approximated by a single break frequency, as shown in Figure 13.2(a). This characteristic can be modeled by the circuit of Figure 13.2(b), a high-frequency op-amp model. If an op-amp has more than one break frequency, it can be represented by using as many capacitors as there are breaks.  $R_{in}$  is the input resistance, and  $R_o$  the output resistance.

The dependent sources in the op-amp model of Figure 13.2(b) have a common node. Without this, PSpice will give an error message because there is no DC path from the nodes of the dependent current source. The common node could be in either the input stage or output stage. This model does not take into account the saturation effect, and is suitable only if the op-amp operates within the linear region.

The output voltage can be expressed as

$$V_o = A_o V_2 = \frac{A_o V_i}{1 + R_i C_1 s}$$

Substituting  $s = j2\pi f$  yields

$$V_o = \frac{A_o V_i}{1 + j2\pi f R_i C_1} = \frac{A_o V_i}{1 + j(f/f_b)}$$

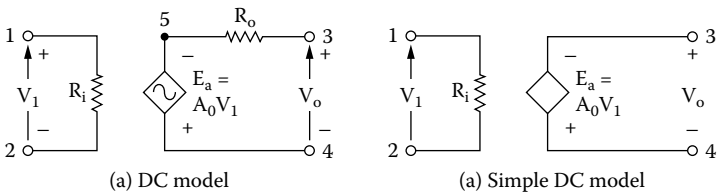
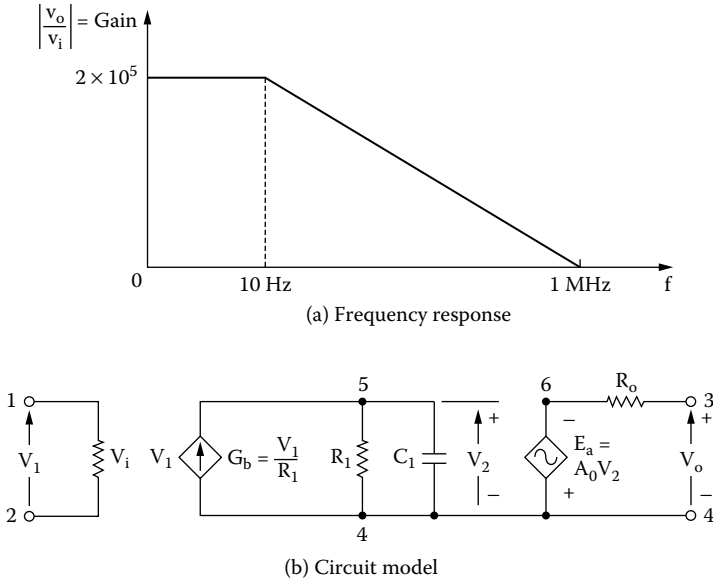


FIGURE 13.1 DC linear op-amp models. (a) DC model, (b) simple DC model.



**FIGURE 13.2** AC linear model with single break frequency. (a) Frequency response, (b) circuit model.

where  $f_b = 1/(2\pi R_1 C_1)$  is called the *break frequency* (in hertz) and  $A_0$  is the *large-signal* (or DC) gain of the op-amp. Thus, the open-loop voltage gain is

$$A(f) = \frac{V_o}{V_i} = -\frac{A_0}{1 + j(f/f_b)}$$

For  $\mu 741$  op-amps,  $f_b = 10$  Hz,  $A_0 = 2 \times 10^5$ ,  $R_1 = 2$  M $\Omega$ , and  $R_0 = 75$   $\Omega$ . Letting  $R_1 = 10$  k $\Omega$ ,  $C_1 = 1/(2\pi \times 10 \times 10 \times 10^3) = 1.15619$   $\mu$ F.

### 13.2.3 NONLINEAR MACROMODELS

The circuit arrangement of the op-amp macromodel is shown in [Figure 13.3](#) [2,3]. The macromodel can be used as a subcircuit with a `.SUBCKT` command. However, if an op-amp is used in various circuits, it is convenient to have the macromodel as a library file (i.e., `EVAL.LIB`), and it is not necessary to type the statements of the macromodel in every circuit in which the macromodel is employed. The library file `EVAL.LIB` that comes with the student version of PSpice has macromodels for op-amps, comparators, diodes, MOSFETs, BJTs, and SCRs. The professional version of PSpice supports library files for many devices. Check the name of the current library file by listing the files of the PSpice programs (by using the DOS command `DIR`).

The macromodel of the  $\mu 741$  op-amp is simulated at room temperature. The library file `EVAL.LIB` contains the op-amp macromodel model as a subcircuit

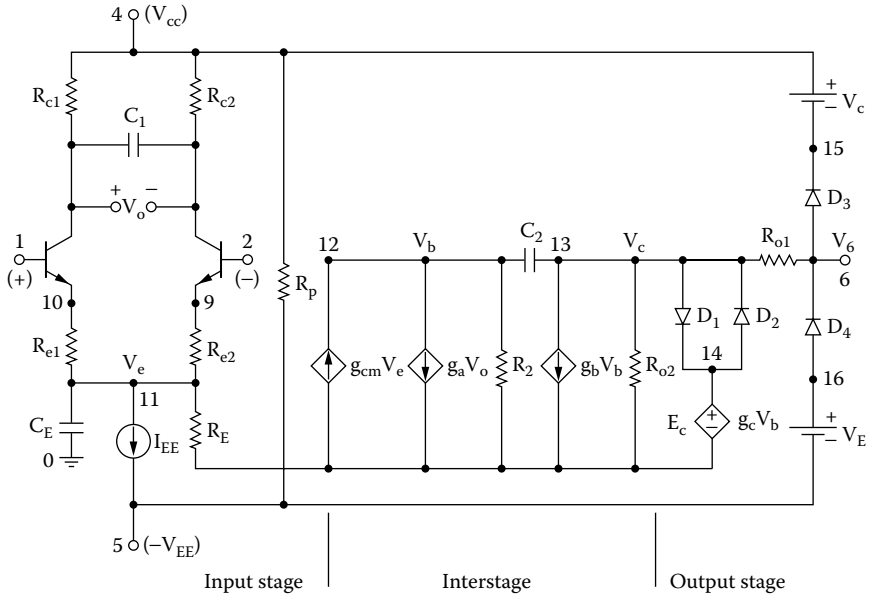


FIGURE 13.3 Circuit diagram of the op-amp macromodel.

definition UA741 with a set of .MODEL statements. This op-amp model contains nominal, not worst-case devices, and does not consider the effects of temperature.

The listing of the subcircuit UA741 in library file EVAL.LIB is as follows:

```

* Subcircuit for μ741 op-amp
* connections:      noninverting input
*                  :      inverting input
*                  :      :
*                  :      :      positive power supply
*                  :      :      :      negative power supply
*                  :      :      :      :      output
*                  :      :      :      :      :
.SUBCKT      UA741      1      2      4      5      6
*                  Vi+      Vi-      Vp+      Vp-      Vout
Q1      7      1      10      UA71QA
Q2      8      2      9      UA741QB
RC1     4      7      5.305165D+03
RC2     4      8      5.305165D+03
C1      7      8      5.459553D-12
RE1     10     11     2.151297D+03
RE2     9      11     2.151297D+03
IEE     11     5      1.666000D-05
CE      11     0      3.000000D-12
RE      11     0      1.200480D+07
    
```

```

GCM      0      12      11      0      5.960753D-09
GA      12      0       8       7      1.884955D-04
R2      12      0       1.000000D+05
C2      12      13      3.000000D-11
GB      13      0      12      0      2.357851D+02
RO2     13      0       4.500000D+01
D1      13      14      UA741DA
D2      14      13      UA741DA
EC      14      0       6       0      1.0
RO1     13      6       3.000000D+01
D3      6       15      UA741DB
VC      4       15      2.803238D+00
D4      16      6       UA741DB
VE      16      5       2.803238D+00
RP      4       5      18.16D+03

```

\* Models for diodes and transistors:

```

.MODEL UA741DA D(IS = 9.762287D-11)
.MODEL UA741DB D(IS = 8.000000D-16)
.MODEL UA741QA NPN (IS = 8.000000D-16 BF = 9.166667D+01)
.MODEL UA741QB NPN (IS = 8.309478D-16 BF = 1.178571D+02)
.ENDS UA741 ;End of subcircuit definition

```

### EXAMPLE 13.1 FINDING THE PERFORMANCE OF AN OP-AMP INVERTING AMPLIFIER

An inverting amplifier is shown in Figure 13.4. Use PSpice to plot the DC transfer characteristic if the input is varied from  $-1$  to  $+1$  V with an  $0.2$ -V increment. (a) Use the op-amp of Figure 13.1(a) as a subcircuit; its parameters are  $A_o = 2 \times 10^5$ ,  $R_i = 2$  M $\Omega$ , and  $R_o = 75$   $\Omega$ . (b) Use the op-amp of Figure 13.2 as a subcircuit; its parameters are  $R_i = 2$  M $\Omega$ ,  $R_o = 75$   $\Omega$ ,  $C_1 = 1.5619$   $\mu$ F, and  $R_1 = 10$  k $\Omega$ . (c) Use the macromodel of Figure 13.3 for the UA741.

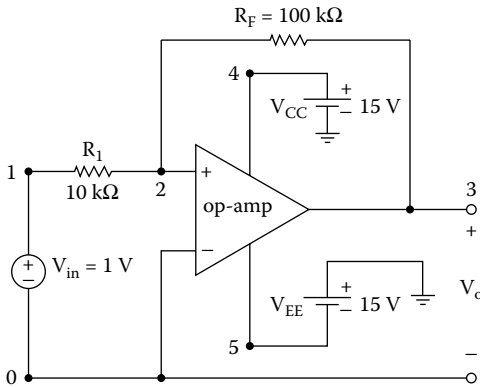


FIGURE 13.4 Inverting amplifier.

**SOLUTION**

The listing of the subcircuit OPAMP-DC for Figure 13.1(a) is as follows:

---

```
* Subcircuit definition for OPAMP-DC:
.SUBCKT  OPAMP-DC      1    2    3    4
*          model name    Vi-  Vi+  Vo+   Vo-
RIN      1    2    2MEG
RO       5    3    75
EA       5    4    2 1 2E+5      ; Voltage-controlled voltage source
* End of subcircuit definition:
.ENDS    OPAMP-DC      ; End of subcircuit definition
```

---

The listing of the subcircuit OPAMP-AC for Figure 13.2 is as follows:

---

```
* Subcircuit definition for OPAMP-AC:
.SUBCKT  OPAMP-AC      1    2    3    4
*          model name    Vi-  Vi+  Vo+   Vo-
RI       1    2    2MEG
GB       4    5    1    2    0.1M  ;Voltage-controlled current source
R1       5    4    10K
C1       5    4    1.5619UF
EA       4    6    5    4    2E + 5 ;Voltage-controlled voltage source
RO       6    3    75
.ENDS    OPAMP-AC      ;End of subcircuit definition
```

---

- (a) The PSpice schematic for a DC op-amp model is shown in Figure 13.5(a), and the DC op-amp model is shown in Figure 13.5(b).

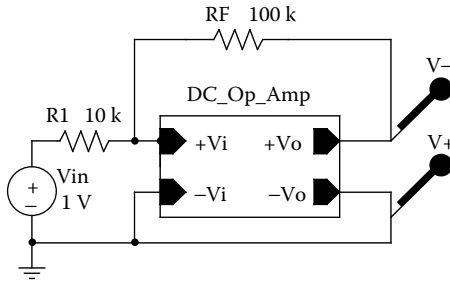
The listing of the circuit file with the DC op-amp model is as follows:

**Example 13.1(a) Inverting amplifier with DC op-amp model**

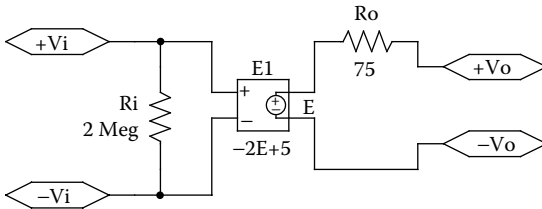

---

```
SOURCE ■ VIN 1 0 DC 1V
CIRCUIT ■■ R1 1 2 10K
           RF 2 3 100K
           * Calling subcircuit OPAMP-DC:
           XA1 2 0 3 0 OPAMP-DC
           * Vi- Vi+ Vo+ Vo- model name
           * Subcircuit definition OPAMP-DC must be inserted.
ANALYSIS ■■■ .DC VIN -1V 1V 0.1V ; DC sweep
              .PROBE ; Graphics post-processor
              .END
```

---



(a)



(b)

**FIGURE 13.5** PSpice schematic for Example 13.1 with a DC op-amp model. (a) Schematic, (b) DC op-amp model.

The plot of the transfer characteristic using the DC op-amp model of Figure 13.1(a) is shown in Figure 13.6. The expected gain is  $R_F/R_1 = 100/10 = 10$ .

(b) The PSpice schematic for an AC op-amp model is shown in Figure 13.7(a), and the AC op-amp model is shown in Figure 13.7(b).

The listing of the circuit file with the AC op-amp model is as follows:

**Example 13.1(b) Inverting amplifier with AC op-amp model**

```

SOURCE   ■ VIN 1 0 DC 1V
CIRCUIT  ■■ R1 1 2 10K
          RF 2 3 100K
          *Calling subcircuit OPAMP-DC:
          XA1 2 0 3 0 OPAMP-DC
          * Vi- Vi+ Vo+ Vo- model name
          * Subcircuit definition OPAMP-DC must be inserted
ANALYSIS ■■■ .DC VIN -1V 1V 0.1V ;DC sweep
              .PROBE ;Graphics post-processor
              .END
    
```

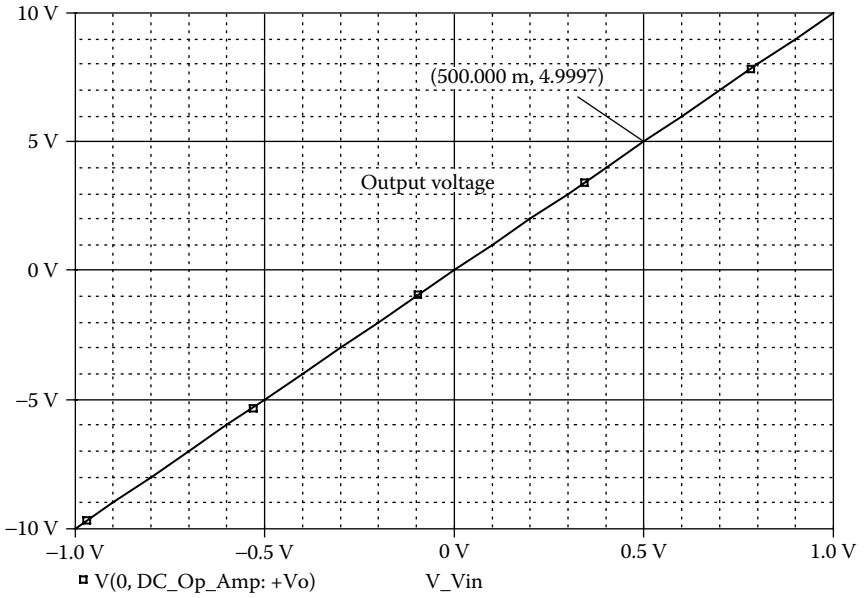


FIGURE 13.6 Plot for Example 13.1 with DC op-amp model.

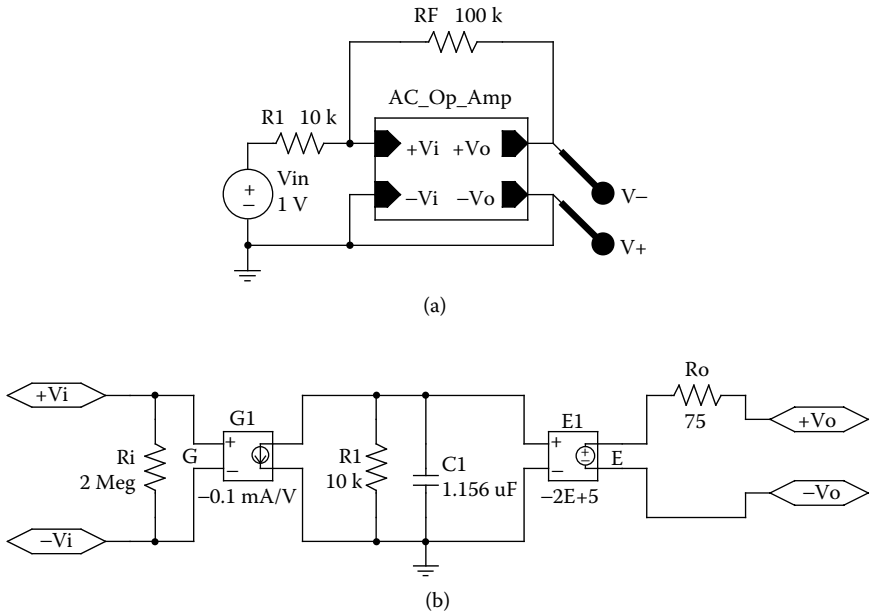
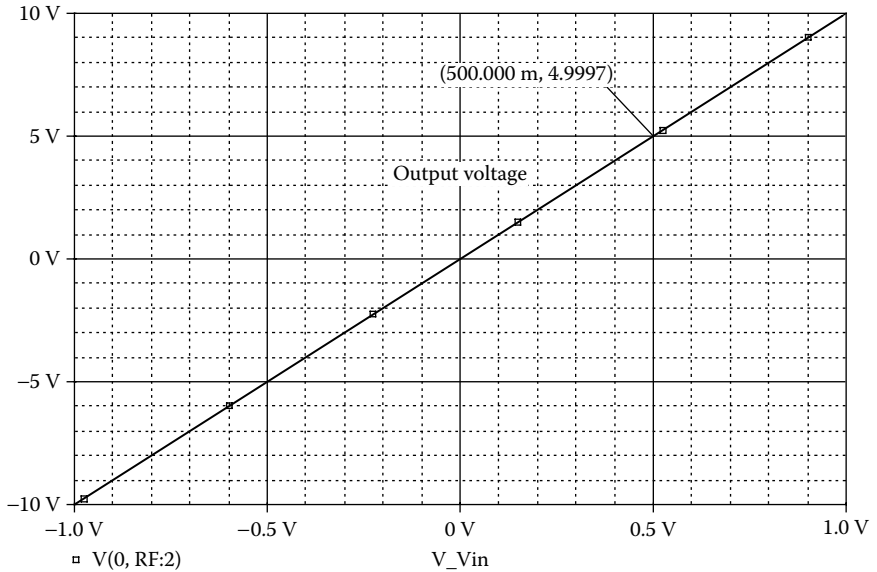


FIGURE 13.7 PSpice schematic for Example 13.1 with an AC op-amp model. (a) Schematic, (b) AC op-amp model.



**FIGURE 13.8** Plot for Example 13.1 with AC op-amp model.

The plot of the transfer characteristic using the AC op-amp model of Figure 13.2 is shown in Figure 13.8. No difference is expected from that obtained with a DC signal. However, the output will be dependent on the frequency of the input signal.

- (c) The PSpice schematic is shown in Figure 13.9 with a built-in op-amp schematic model.

The listing of the circuit file with the UA741 macromodel is as follows:

### Example 13.1(c) Inverting amplifier with mA741 macromodel

```

SOURCE   ■ VIN 1 0 DC 1V
CIRCUIT  ■■ R1  1 2 10K
          RF  2 3 100K
          VCC 4 0 DC 15V
          VEE 0 5 DC 15V
          * Calling subcircuit op-amp UA741:
          XA1 2  0  4  5  3      UA741
          * Vi- Vi+ Vp+ Vp- Vout  model name
          * Subcircuit definition UA741-DC must be inserted.
ANALYSIS ■■■ .DC VIN -1V 1V 0.1V      ; DC sweep
          .PROBE                          ; Graphics post-processor
          .END
  
```

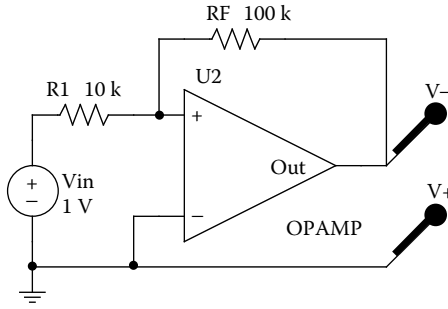


FIGURE 13.9 PSpice schematic for Example 13.1 with a schematic op-amp model.

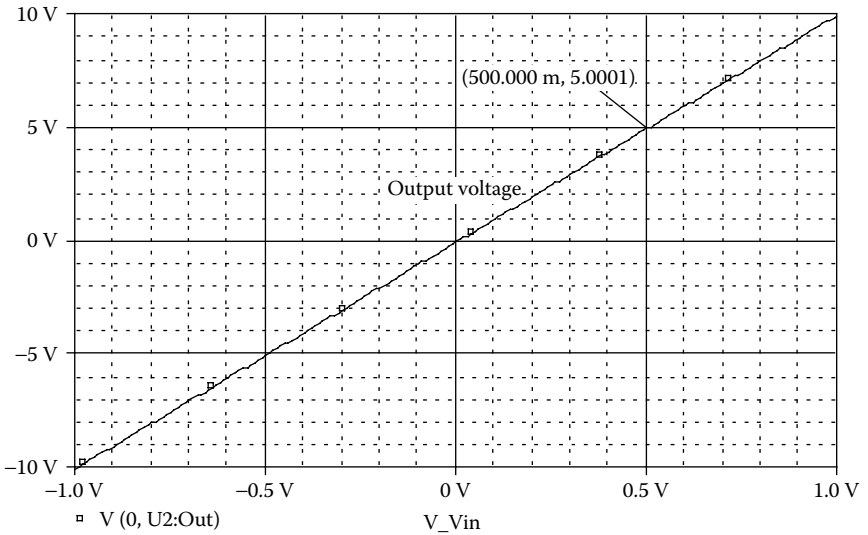


FIGURE 13.10 Plot for Example 13.1 with the UA741 macromodel.

The plot of the transfer characteristic using the UA741 macromodel of Figure 13.3 is shown in Figure 13.10. A macromodel affects the characteristics because it has saturation limits. The voltage gain is 4.98.

**EXAMPLE 13.2 FINDING THE PERFORMANCE OF AN OP-AMP INTEGRATOR**

An op-amp integrator circuit is shown in Figure 13.11(a). The input voltage is shown in Figure 13.11(b). Use PSpice to plot the transient response of the output voltage for a duration of 0 to 4 msec in steps of 50 μsec.

**SOLUTION**

The PSpice schematic shown in Figure 13.12(a) with a schematic op-amp model,  $V_{POS} = 15\text{ V}$  and  $V_{NEG} = -15\text{ V}$ . The ABM is shown in Figure 13.12(b).

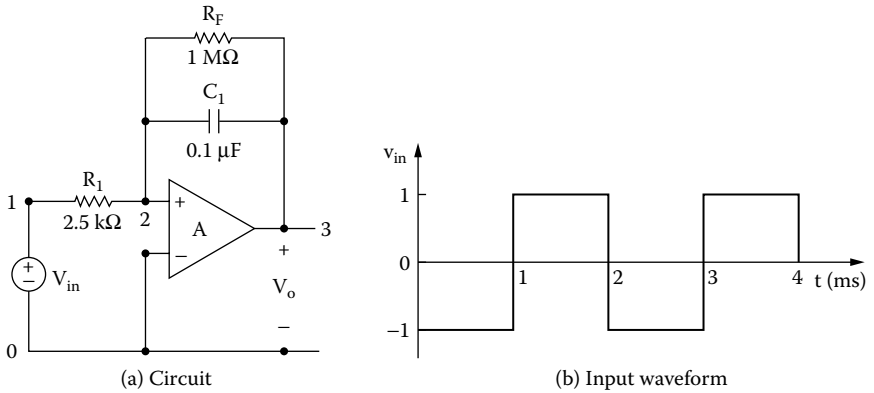


FIGURE 13.11 Integrator circuit. (a) Circuit, (b) input waveform.

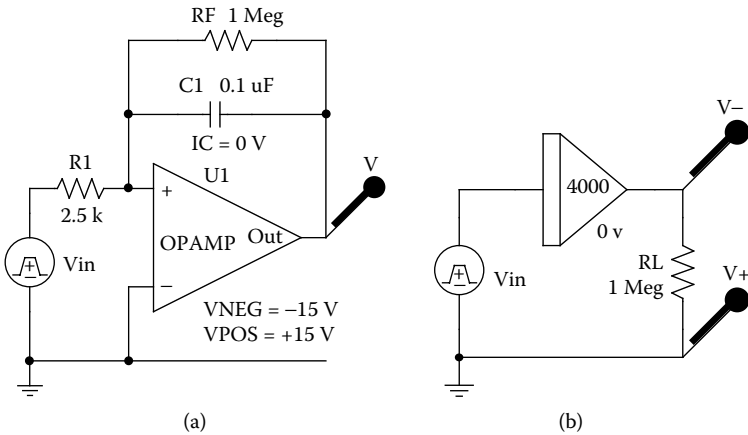


FIGURE 13.12 PSpice schematic for Example 13.2 with a schematic op-amp model. (a) Op-amp integrator, (b) ABM integrator.

The listing of the circuit file with the op-amp DC model is as follows:

**Example 13.2 Integrator circuit with op-amp DC model**

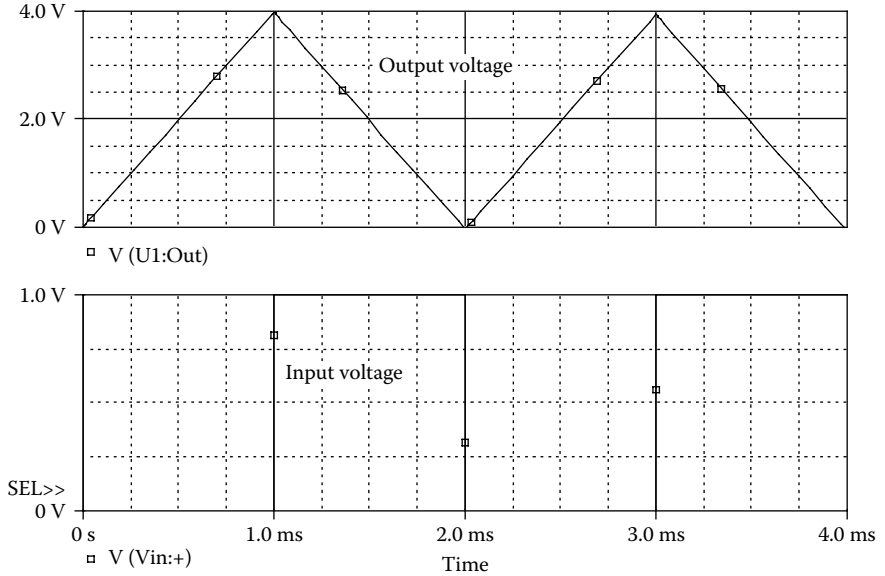
```

SOURCE ■ VIN 1 0 PULSE (-1V 1V 1MS 1NS 1NS 1MS 2MS) ; Pulse
        waveform
CIRCUIT ■■ R1 1 2 2.5K
            RF 2 3 1MEG
            C1 2 3 0.1UF IC = 0V ; Set initial condition
            * Calling subcircuit OPAMP-DC:
            XA1 2 0 3 0 OPAMP-DC
    
```

```

*   Vi- Vi+ Vo+ Vo- model name
*   Subcircuit definition OPAMP-DC must be inserted
ANALYSIS ■■■ .TRAN 10US 4MS UIC ; Use initial condition in transient
analysis
               .PLOT TRAN V(3) V(1)      ; Prints on the output file
               .PROBE                      ; Graphics post-processor
               .END

```



**FIGURE 13.13** Transient response for Example 13.2 with the op-amp DC model.

The plot of the transient response using the op-amp DC model is shown in Figure 13.13. The output voltage is triangular in response to a square-wave input. Equating the areas under two curves, the expected height  $h$  is given by  $0.5 \times 1 \text{ msec}$  or  $h = (1 \text{ V} + 1 \text{ V}) \times 1 \text{ msec}$ , or  $h = 4 \text{ V}$ , which is verified by SPICE simulation.

### EXAMPLE 13.3 FINDING THE PERFORMANCE OF A DIFFERENTIATOR

A practical differentiator circuit is shown in Figure 13.14(a). The input voltage is shown in Figure 13.14(b). Use PSpice to plot the transient response of output voltage for a duration of 0 to 4 msec in steps of 50  $\mu\text{sec}$ .

### SOLUTION

The PSpice schematic is shown in Figure 13.15(a) with a schematic op-amp model,  $V_{\text{POS}} = 15 \text{ V}$  and  $V_{\text{NEG}} = -15 \text{ V}$ . The ABM is shown in Figure 13.15(b).

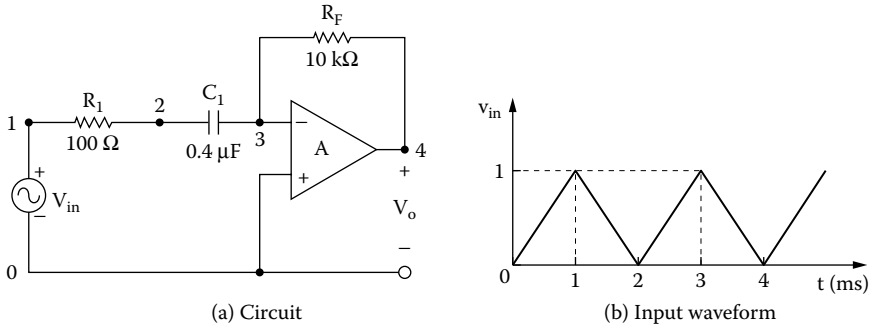


FIGURE 13.14 Differentiator circuit. (a) Circuit, (b) input waveform.

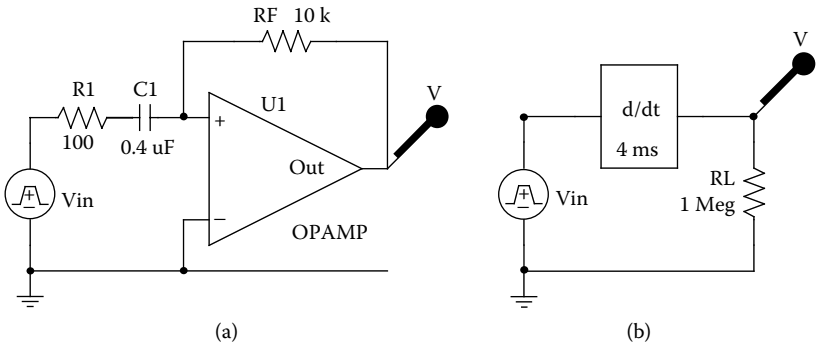


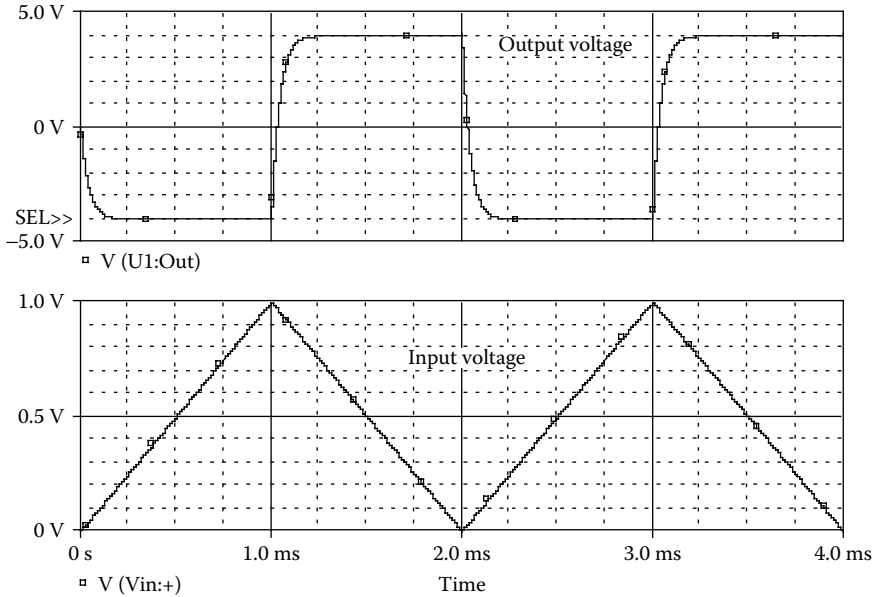
FIGURE 13.15 PSpice schematic for Example 13.3 with a schematic op-amp model. (a) Op-amp differentiator, (b) ABM differentiator.

The listing of the circuit file is as follows:

**Example 13.3 Differentiator circuit**

```

SOURCE ■ VIN 1 0 PULSE (0 1V 0 1MS 1MS 1NS 2MS) ; Pulse waveform
CIRCUIT ■■ R1 1 2 100
           C1 2 3 0.4UF
           RF 3 4 10K
           * Calling subcircuit OPAMP-DC:
           XA1 3 0 4 0 OPAMP-DC
           * Vi- Vi+ Vo+ Vo- model name
           * Subcircuit definition OPAMP-DC must be inserted.
ANALYSIS ■■■ .TRAN 10US 4MS ; Transient analysis
             .PLOT TRAN V(4) V(1) ; Prints on the output file
             .PROBE ; Graphics post-processor
             .END
    
```



**FIGURE 13.16** Transient response for Example 13.3.

The plot of the transient response is shown in Figure 13.16. The output voltage is a square wave in response to a triangular input. The time constant of the circuit limits the sharp rise and fall of the output voltage.

### 13.3 CONTROL SYSTEMS

The simulation of control systems requires integrators, multipliers, summing amplifiers, and function generators. These features can easily be simulated by PSpice. Additional PSpice features, such as Polynomial, Table, Frequency, Laplace, Parameter, Value, and Step, make PSpice a versatile tool to simulate complex control systems.

#### **EXAMPLE 13.4 FINDING THE STEP RESPONSE OF UNITY FEEDBACK CONTROL SYSTEM**

A unity feedback control system is shown in Figure 13.17. The reference input  $v_r$  is a step voltage of 1 V. Use PSpice to plot the transient response of the output voltage  $v_o$  for a duration of 0 to 10 sec in steps of 10 msec. The gain  $K$  is to be varied from 0.5 to 2 with an increment of 0.5. Assume that all initial conditions are zero.

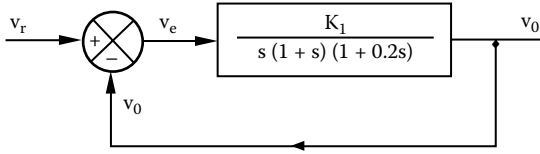


FIGURE 13.17 Unity feedback control system.

### SOLUTION

The relations among  $V_r$ ,  $V_o$ , and  $V_e$ , in Laplace's  $s$  domain, are

$$V_e(s) = V_r(s) - V_o(s)$$

$$\frac{V_o(s)}{V_e(s)} = \frac{K}{s(1+s)(1+0.2s)}$$

which gives

$$[s(1+s)(1+0.2s)]V_o(s) = KV_e(s)$$

$$[s + 1.2s^2 + 0.2s^3]V_o(s) = KV_e(s)$$

which can be written in the time domain as

$$0.2 \frac{d^3 v_o}{dt^3} + 1.2 \frac{d^2 v_o}{dt^2} + \frac{dv_o}{dt} = K v_e = K(v_r - v_o) \quad (13.1)$$

Dividing both sides by 0.2 gives

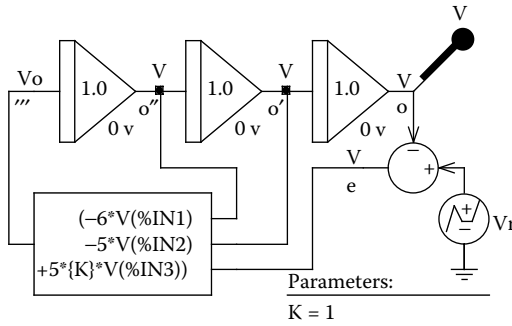
$$\frac{d^3 v_o}{dt^3} + 6 \frac{d^2 v_o}{dt^2} + 5 \frac{dv_o}{dt} = 5K v_e$$

where  $v_e = v_r - v_o$ , or

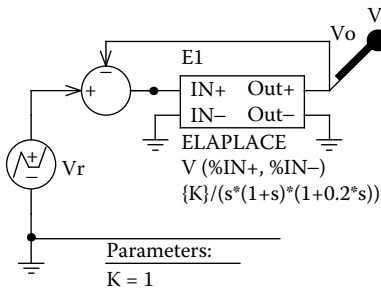
$$\frac{d^3 v_o}{dt^3} = -6 \frac{d^2 v_o}{dt^2} - 5 \frac{dv_o}{dt} + 5K v_e \quad (13.2)$$

which can be denoted by

$$\ddot{v}_o = -6\dot{v}_o - 5v_o + 5K v_e \quad (13.3)$$



(a)



(b)

**FIGURE 13.18** Unity feedback control system for PSpice schematic of Example 13.4. (a) Analog representation, (b) ABM representation.

Integrating the third derivative three times should yield the second derivative of  $v_o$ , the first derivative of  $v_o$ , and the output  $v_o$ . The third derivative on the left-hand side of Equation 13.3 must equal the sum of the terms on the right-hand side. The circuit for PSpice simulation of Equation 13.2 is shown in Figure 13.18.

The gain  $K$  is defined in PSpice as a variable.

The input voltage  $v_{in}$  is obtained from

$$v_{in} = \ddot{v}_o = -6\dot{v}_o - 5v_o + 5Kv_e$$

It should be noted that the output signal of an integrator is inverted. This should be taken into account in summing signals  $v_{in}$  and  $v_e$ .

We can use the ABMs to represent the transfer function and the comparator as shown in Figure 13.18(b).

The listing of the circuit file is as follows:

---

### Example 13.4 Unity feedback control system with a step input

```

SOURCE  ■ Vr 8 0 PWL (0 0V 1NS 1V 10MS 1V) ; Reference voltage
        Rg 8 0 10MEG
CIRCUIT ■■ .PARAM VAL = 10K ; Parameter VAL
          .STEP PARAM VAL 10K 40K 10K ; Step change of parameter VAL
R1  1  2  1K
C1  2  3  0.001 IC = 0V      ; Set initial condition
R2  3  4  1K
C2  4  5  0.001 IC = 0V      ; Set initial condition
R3  5  6  1K
C3  6  7  0.001 IC = 0V      ; Set initial condition
R   9 10 20K
RF 10 11 {VAL}
* Calling subcircuit OPAMP-DC:
XA1 2  0  3  0  OPAMP-DC
XA2 4  0  5  0  OPAMP-DC
XA3 6  0  7  0  OPAMP-DC
XA4 10 0 11  0  OPAMP-DC
E1  9  0  POLY(2)  8  0  7  0  0  1  1
E2  1  0  POLY(3)  3  0  5  0  11  0  0  6.0 -5.0 -5.0
* Subcircuit definition OPAMP-DC must be inserted.
ANALYSIS ■■■ .TRAN 0.01S 10S UIC      ; Use initial condition in
            transient analysis
            .PLOT TRAN V(7)          ; Prints on the output file
            .OPTIONS ABSTOL = 1.00N RELTOL = 0.01 VNTOL = 0.1 ITL5 = 0
            .PROBE                    ; Graphics post-processor
            .END

```

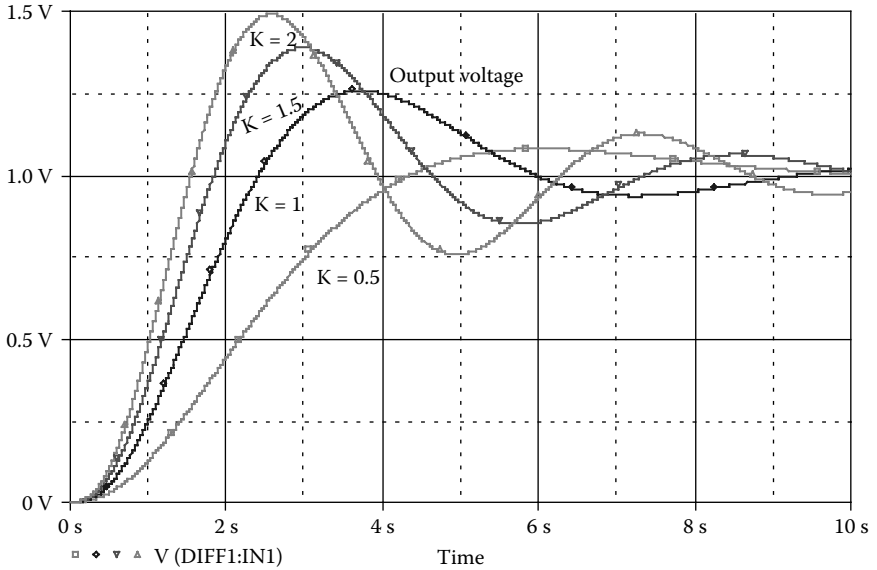
---

The plot of the transient response for the feedback control system is shown in [Figure 13.19](#). A higher value of  $K$  gives more overshoot and the system tends to be unstable. The transient should settle to the input signal level.

### EXAMPLE 13.5 FINDING THE TRANSIENT PLOT OF THE VAN DER POL EQUATION

The well-known Van der Pol equation is represented by

$$\ddot{y} - \mu(1 - y^2)\dot{y} + y = 0$$



**FIGURE 13.19** Transient response for Example 13.4.

Use PSpice to plot the transient response of the output signal for a duration of 0 to 20 sec in steps of 10 msec, and the phase plane ( $dy/dt$  against  $y$ ). Assume a constant  $\mu = 2$  and an initial disturbance of 0.1 unit.

**SOLUTION**

The Van der Pol equation can be written as

$$\frac{d^3y}{dt^2} = \mu(1 - y^2) \frac{dy}{dt} - y \tag{13.4}$$

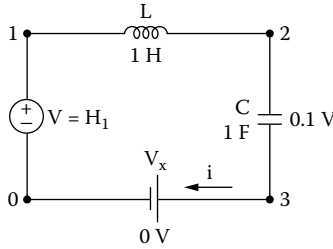
This is identical to that for the LC circuit of Figure 13.20. Let us assume that  $L = 1$  H and  $C = 1$  F. The equation describing the LC circuit of Figure 13.20 is

$$v = L \frac{di}{dt} + \frac{1}{C} \int i dt = \frac{dv}{dt} + \int i dt$$

Differentiating both sides yields

$$\frac{dv}{dt} = \frac{d^2i}{dt^2} + i$$

Solving for  $d^2i/dt^2$ , we get



**FIGURE 13.20** LC circuit for representing the Van der Pol equation.

$$\frac{d^2i}{dt^2} = \frac{dv}{dt} - i \tag{13.5}$$

Equation 13.4 will be identical to Equation 13.5 if the current  $i$  represents  $y$  and  $dv/dt$  equals

$$\frac{dv}{dt} = \mu(1 - y^2) \frac{dy}{dt} = \mu(1 - i^2) \frac{di}{dt} \tag{13.6}$$

which can be integrated to give

$$v = \int \mu(1 - i^2) di = \mu \left( i - \frac{i^3}{3} \right) \tag{13.7}$$

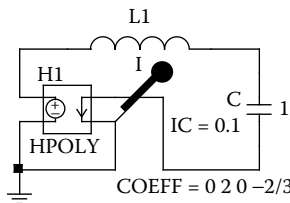
Equation 13.7 is a polynomial of the form

$$v = P_0 + P_1i + P_2i^2 + P_3i^3$$

where  $P_0 = P_2 = 0$ ,  $P_1 = 2$ , and  $P_3 = -\mu/3$ .

The voltage across the inductor  $v_L = di/dt$  represents  $dy/dt$ .

The PSpice schematic is shown in Figure 13.21.



**FIGURE 13.21** PSpice schematic for Example 13.5.

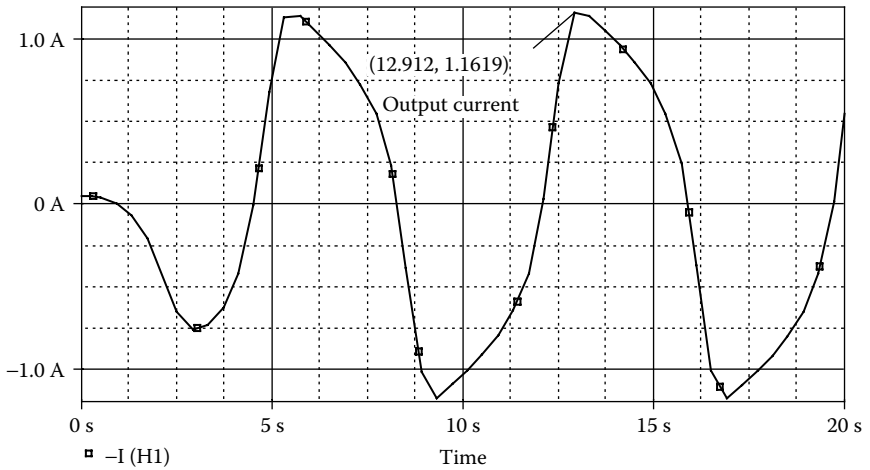


FIGURE 13.22 Transient response of the Van der Pol equation in Example 13.5.

The listing of the circuit file is as follows:

---

### Example 13.5 Van der Pol's equation

```

CIRCUIT ■ H1 1 0 POLY(1) VX 0 2 0 -2/3
           L 1 2 1
           C 2 3 1 IC = 0.1      ; Set initial condition
           VX 3 0 DC 0V          ; Senses the circuit current
ANALYSIS ■ .TRAN 0.01S 20S UIC ; Use initial condition in transient
           analysis
           .PLOT TRAN I(VX) V(1) ; Prints on the output file
           .OPTIONS ABSTOL = 1.00N RELTOL = 0.01 VNTOL = 0.1 ITL5 = 0
           .PROBE                ; Graphics post-processor
           .END

```

---

The plots of the transient response and the phase plane for the Van der Pol equation are shown in Figure 13.22 and Figure 13.23, respectively. The system is unstable and oscillates between limit cycles. A smoother curve can be obtained by reducing the printing time of 0.01 sec.

## 13.4 SIGNAL CONDITIONING

An op-amp can be used for wave shaping to yield a desired control characteristic. The student version of PSpice allows only one op-amp macromodel; it also increases the computation time. Simple  $RC$  circuits can be used to perform the functions of an op-amp, thereby reducing the computation time. We illustrate the applications of  $RC$  circuits in performing the following operations:

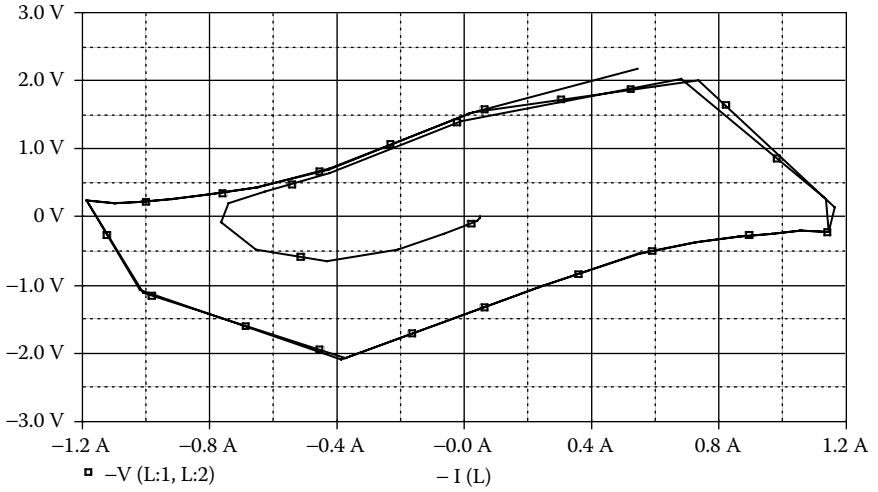


FIGURE 13.23 Phase plane plot of the Van der Pol equation in Example 13.5.

- Integration
- Averaging
- Rms
- Hysteresis

**EXAMPLE 13.6 FINDING THE TRANSIENT RESPONSE OF AN INTEGRATING CIRCUIT**

The input signal  $v_{in} = \sin(120\pi t + 90^\circ)$  is to be integrated and then fed to a load resistance  $R_L = 1 \text{ G}\Omega$ . This is shown in Figure 13.24(a). Use PSpice to plot the

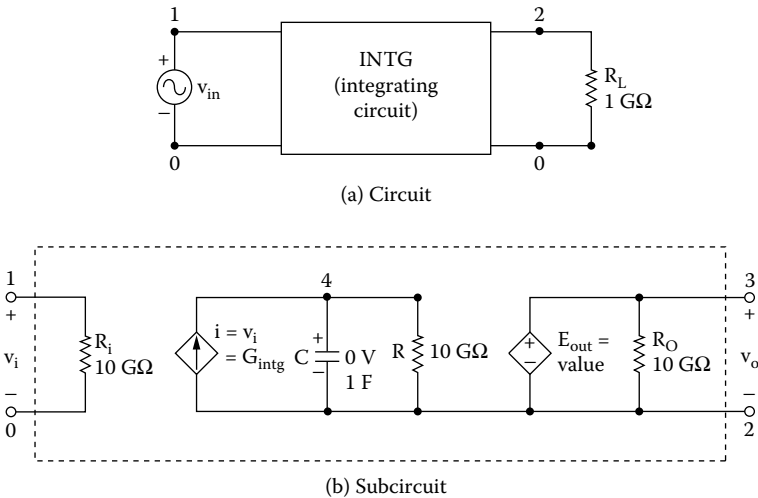


FIGURE 13.24 Integrating circuit. (a) Circuit, (b) subcircuit.

transient response of the input and output voltages for a duration of 0 to 33.33 msec in steps of 10  $\mu$ sec.

### SOLUTION

The integration is accomplished by the  $RC$  circuit of Figure 13.24(b). The input frequency is  $f = 60$  Hz.

The PSpice schematic is shown in Figure 13.25(a) with a capacitor integrator. Figure 13.25(b) shows an implementation with an ABM integrator.

The listing of the circuit file is as follows:

---

### Example 13.6 Integrating circuit

```

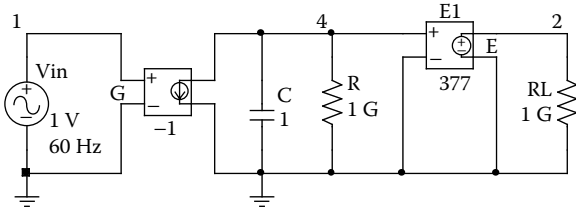
SOURCE ■ VIN 1 0 SIN (0 1V 60HZ 0 0 90DEG)
CIRCUIT ■■ .PARAM FREQ = 60HZ ; Input frequency in hertz
               .PARAM TWO-PI = 6.2832
               RL 2 0 1G
               * Calling subcircuit INTG:
               X1 1 2 0 INTG
               * Vi- Vo+ Vo- model name
               * Subcircuit definition for INTG:
               .SUBCKT INTG 1 3 2 PARAMS: FREQ = 60HZ
               * model name Vi+ Vo+ Vo-
               RI 1 0 10G
               GINTG 2 4 1 0 1
               C 4 2 1 IC=0V
               R 4 2 10G
               EOUT 3 2 VALUE = {V(4, 2) *TWO-PI*FREQ}
               RO 3 2 10G

               .ENDS INTG ; End of subcircuit definition
ANALYSIS ■■■ .TRAN 10US 33.33MS UIC ; Use initial condition in
                transient analysis
                .PLOT TRAN V(2) V(1) ; Prints on the output file
                .OPTIONS ABSTOL = 1.00N RELTOL = 0.01 VNTOL = 0.1
                ITL5 = 0
                .PROBE ; Graphics post-processor
                .END

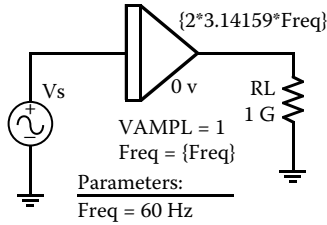
```

---

The plot of the transient response for the input and output voltages are shown in Figure 13.26. The output is a sine wave in response to a cosine signal.

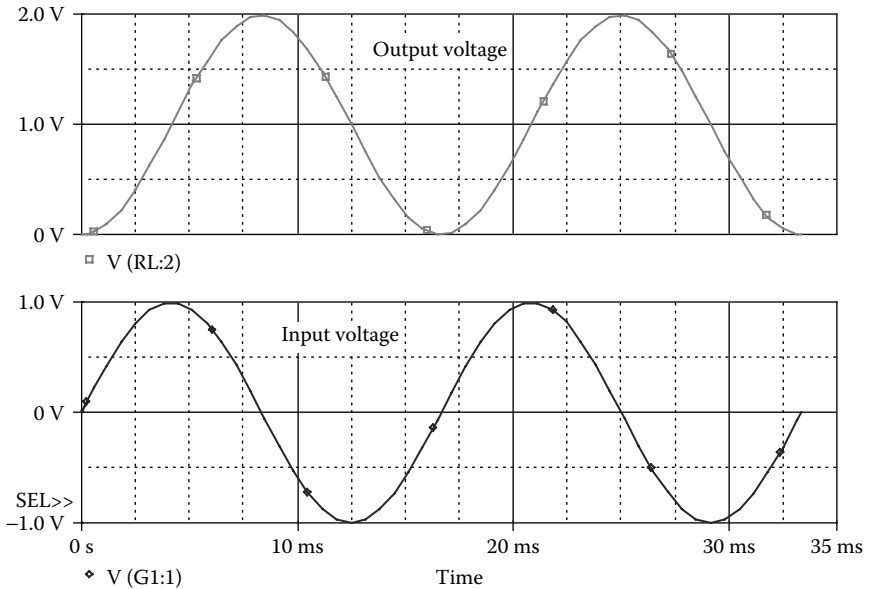


(a)



(b)

**FIGURE 13.25** PSpice schematic for Example 13.6. (a) Capacity integrator, (b) ABM integrator.



**FIGURE 13.26** Transient response of the integrator circuit of Example 13.6.

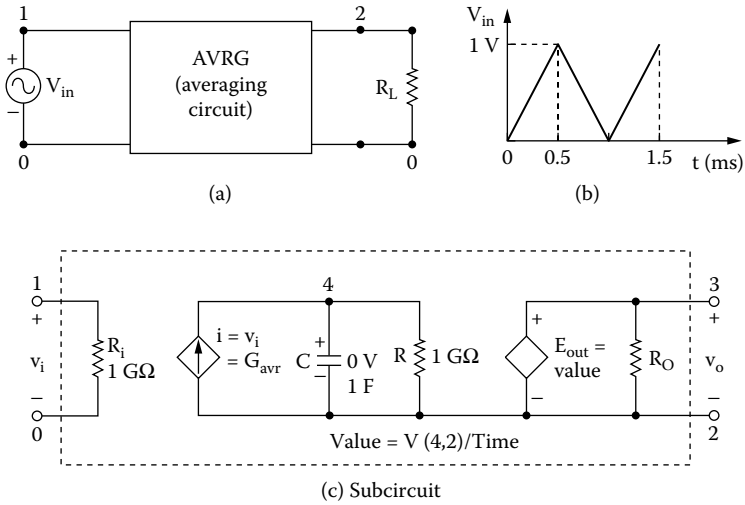


FIGURE 13.27 Averaging circuit. (a) Circuit, (b) input signal, (c) subcircuit.

**EXAMPLE 13.7 FINDING THE TRANSIENT RESPONSE OF AN AVERAGING CIRCUIT**

An input signal is to be averaged and then fed to a load resistance  $R_L = 1 \text{ G}\Omega$ . This is shown in Figure 13.27(a). The input signal is a triangular wave, as shown in Figure 13.27(b). Use PSpice to plot the transient response of input and output voltages for a duration of 0 to 33.33 msec in steps of 10  $\mu\text{sec}$ .

**SOLUTION**

The averaging is accomplished by the RC circuit of Figure 13.27(c). This is similar to Example 13.6, except that the value is divided by time. The input frequency is  $f = 1 \text{ kHz}$ .

The PSpice schematic is shown in Figure 13.28(a) with an averaging circuit. Figure 13.28(b) shows an implementation with an ABM integrator.

The listing of the circuit file is as follows:

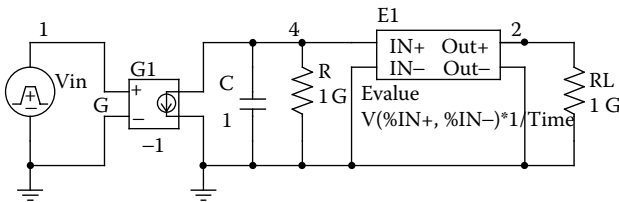
**Example 13.7 Averaging circuit**

```

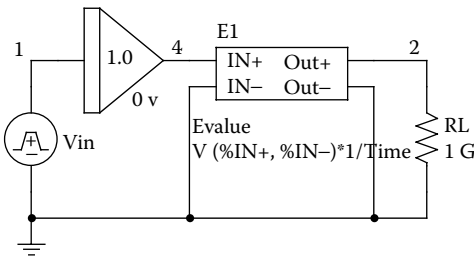
SOURCE  ■ VIN 1 0 PULSE (0 1V 0 0.5MS 0.5MS 1NS 1MS)
CIRCUIT ■■ RL 2 0 1G
          * Calling subcircuit AVR:
          X1 1 2 0 INTG
          * Vi- Vo+ Vo- model name
    
```

```

* Subcircuit definition for AVRГ:
.SUBCKT AVRГ 1 3 2
*      model name Vi+ Vo+ Vo-
RI 1 0 1G
GAVR 2 4 1 0 1
C 4 2 1 IC=0V
R 4 2 1G
EOUT 3 2 VALUE = {V(4,2)/TIME}
RO 3 2 1G
.ENDS AVRГ ; End of subcircuit definition
ANALYSIS ■■■ .TRAN 10US 4MS UIC ; Use initial condition in transient
analysis
.PLOT TRAN V(2) V(1) ; Prints on the output file
.OPTIONS ABSTOL = 1.00N RELTOL = 0.01 VNTOL = 0.1 ITL5 = 0
.PROBE ; Graphics post-processor
.END
    
```



(a)



(b)

**FIGURE 13.28** PSpice schematic for Example 13.7. (a) Averaging circuit, (b) ABM integrator.

The plots of the transient response for the input and output voltages are shown in [Figure 13.29](#). Under steady-state conditions, the average value of a triangular wave remains constant at  $0.5bh/T = 0.5 \times 1 \text{ msec} \times 1 \text{ V}/1 \text{ msec} = 0.5 \text{ V}$ .

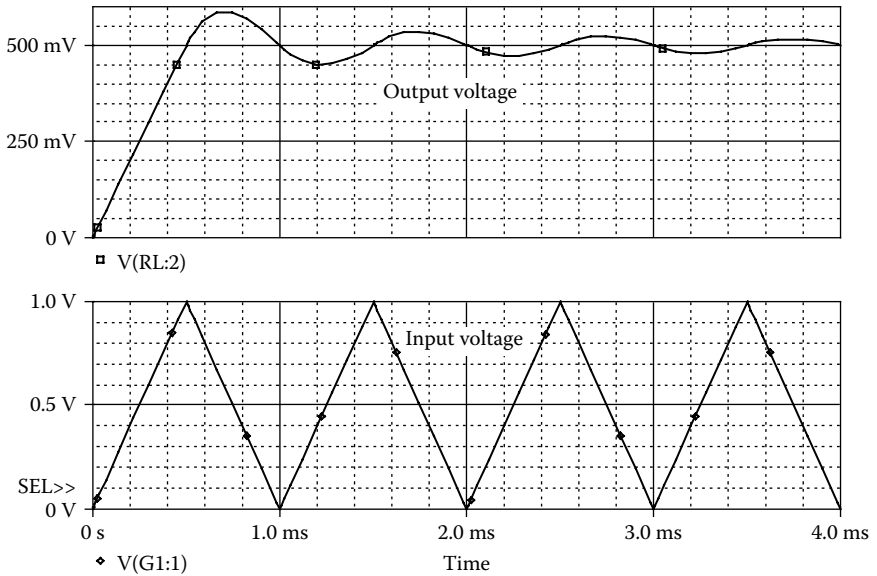


FIGURE 13.29 Transient response for the averaging circuit of Example 13.7.

**EXAMPLE 13.8 FINDING THE TRANSIENT RESPONSE OF AN RMS CIRCUIT**

The rms value of an input signal  $v_{in} = \sin(120\pi t)$  is to be fed to a load resistance  $R_L = 1 \text{ G}\Omega$ . This is shown in Figure 13.30(a). Use PSpice to plot the transient response of the input and output voltages for a duration of 0 to 33.33 msec in steps of 10  $\mu\text{sec}$ .

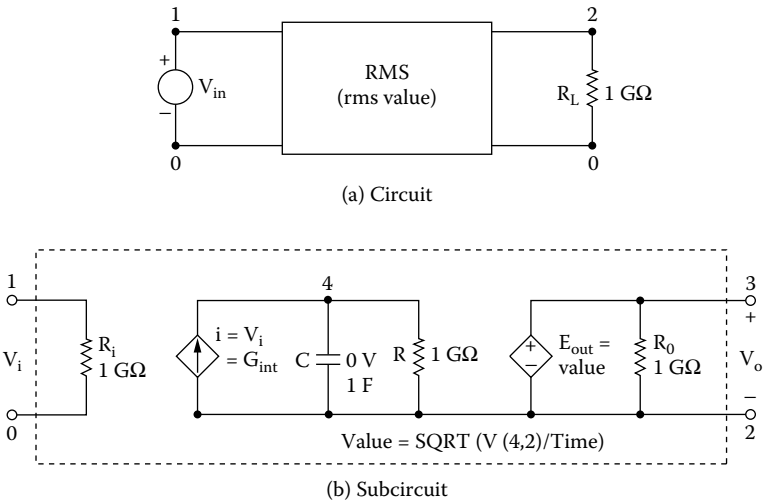


FIGURE 13.30 Rms value circuit. (a) Circuit, (b) subcircuit.

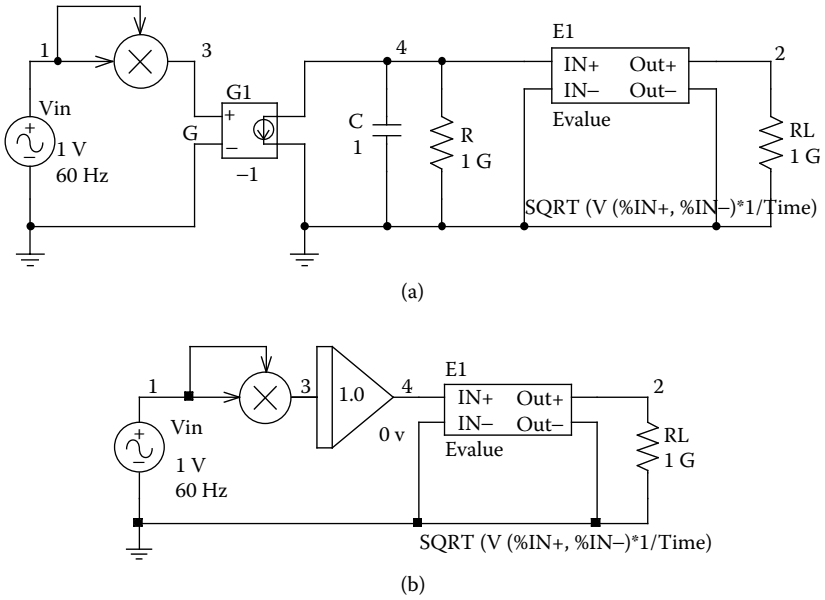


FIGURE 13.31 Pspice schematic for Example 13.8. (a) Rms circuit, (b) ABM integrator.

**SOLUTION**

The rms value is determined by the RC circuit of Figure 13.30(b). The input frequency is  $f = 60$  Hz.

The PSpice schematic is shown in Figure 13.31(a) for an rms circuit. Figure 13.31(b) shows an implementation with an ABM integrator.

The listing of the circuit file is as follows:

**Example 13.8 RMS circuit**

```

SOURCE  ■ VIN  1  0  SIN (0 1V 60HZ)
CIRCUIT  ■■ RL  2  0  1G

* Calling subcircuit RMS:
X1  1  2  0      RMS
*  Vi+  Vo+  Vo-  model name
* Subcircuit definition for RMS:
.SUBCKT      RMS      1  3  2
*          model name Vi+  Vo+  Vo-
RI  1  0  1G
GAVR  2  4  VALUE = {V(1)*V(1)}
C  4  2  1  IC=0V
    
```

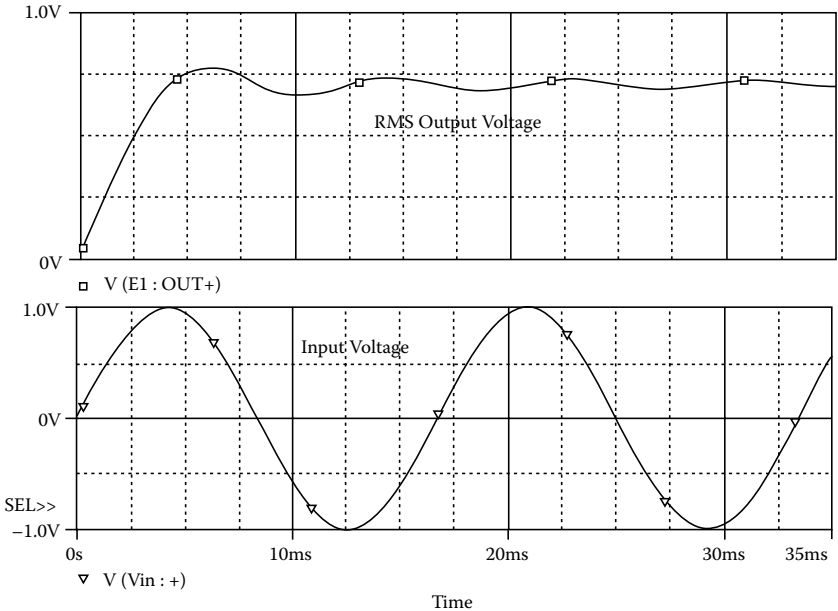
```

R      4  2  1G
EOUT  3  2  VALUE = {SQRT (V(4,2)/TIME)}
RO     3  2  1G

.ENDS RMS ; End of subcircuit definition
ANALYSIS ■■■ .TRAN 10US 33.33MS UIC ; Use initial condition in
transient analysis
.PLOT TRAN V(2) V(1) ; Prints on the output file
.OPTIONS ABSTOL = 1.00N RELTOL = 0.01 VNTOL = 0.1
ITL5 = 0
.PROBE ; Graphics post-processor
.END

```

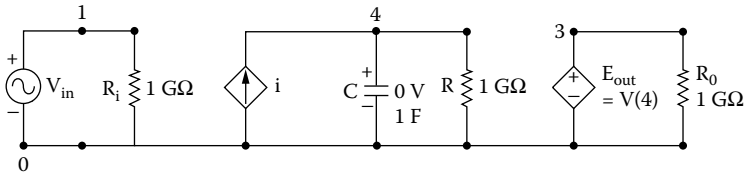
The plots of the transient response for the input and output voltages are shown in Figure 13.32. The rms value of a sine wave with 1 V peak is  $1\text{ V}/\sqrt{2} = 0.707\text{ V}$ .



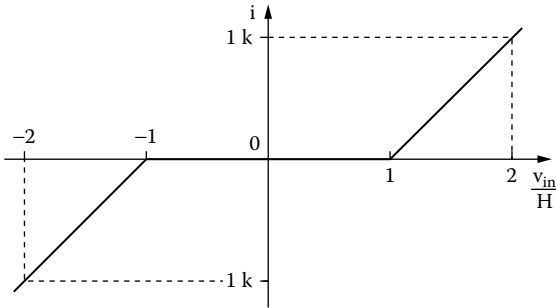
**FIGURE 13.32** Transient response for the rms circuit of Example 13.8.

### EXAMPLE 13.9 FINDING THE TRANSIENT RESPONSE OF AN INTEGRATING CIRCUIT WITH A HYSTERESIS LOOP

The input signal to the integrating circuit of Figure 13.33(a) is  $v_{in} = 2 \sin(120\pi t)$ . The plot of current  $i$  against  $V_{in}/H$  is shown in Figure 13.33(b). Use PSpice to calculate the transient response for a duration of 0 to 33.33 msec in steps of 10  $\mu\text{sec}$ , and to plot the output voltage  $V_o$  against the input voltage  $V_{in}$ .



(a) Circuit



(b) Hysteresis

**FIGURE 13.33** Hysteresis circuit. (a) Circuit, (b) hysteresis.

**SOLUTION**

The input frequency is  $f = 60$  Hz. The PSpice schematic is shown in Figure 13.34 for an integrating circuit with a hysteresis loop.

The listing of the circuit file is as follows:

**Example 13.9 Hysteresis loop**

```

SOURCE  ■ VIN 1 0 SIN (0 2V 60HZ)
CIRCUIT  ■■ .PARAM H = 2 ; Hysteresis
          RL 3 0 1G
          RI 1 0 1G
          GTAB 0 4 TABLE {V(1)/(H/2)} = ;Table for ratio Vin/(H/2)
          + (-2 -1K) (-1, 0) (1, 0) (2 1K)
          C 4 0 1 IC=0V
          R 4 0 1G
          EOUT 3 0 4 0 1
ANALYSIS  ■■■ .TRAN 0.1MS 16.67MS UIC ; Use initial condition in
              transient analysis
              .PLOT TRAN V(3) V(1) ; Prints on the output file
              .OPTIONS ABSTOL = 1.00N RELTOL = 0.01 VNTOL = 0.1 ITL5 = 0
              .PROBE ; Graphics post-processor
          .END
    
```

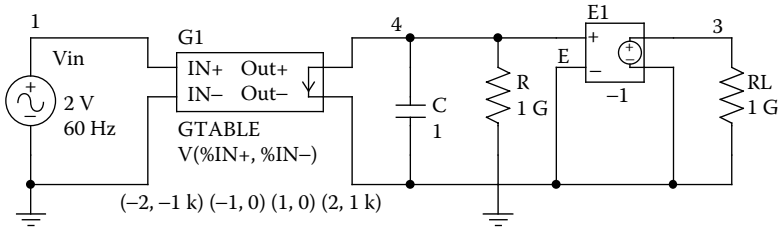


FIGURE 13.34 PSpice schematic for Example 13.9.

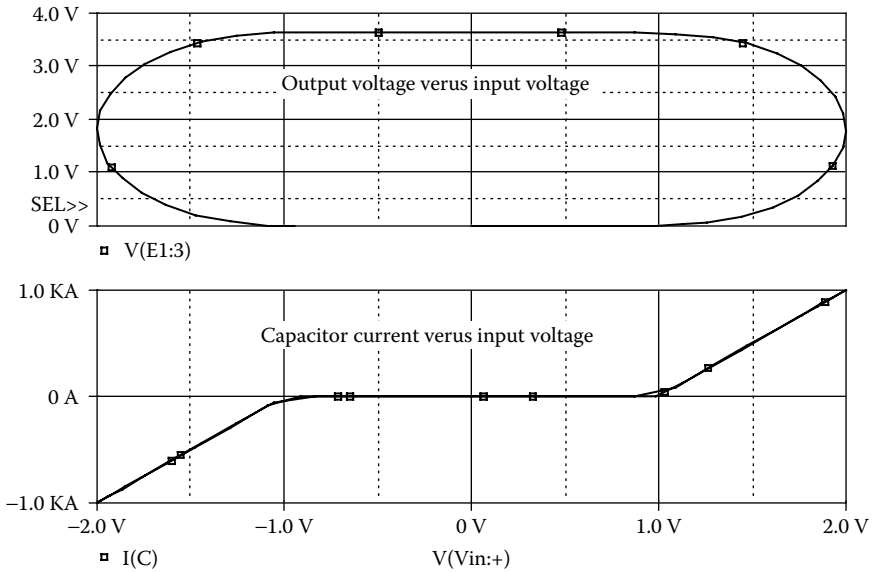


FIGURE 13.35 Output voltage against the input voltage for Example 13.9.

The plot of the output voltage  $V(3)$  against the input voltage  $V(1)$  is shown in Figure 13.35. The output remains constant during the hysteresis band.

### 13.5 CLOSED-LOOP CURRENT CONTROL

Closed-loop control is used in many power electronics circuits to control the shape of a particular current (e.g., inductor motor with current control, and current source inverter). In the following example we illustrate the simulation of a current-controlled rectifier circuit such that the output current of the rectifier is half a sine wave, thereby giving a sine wave at the input side of the rectifier.

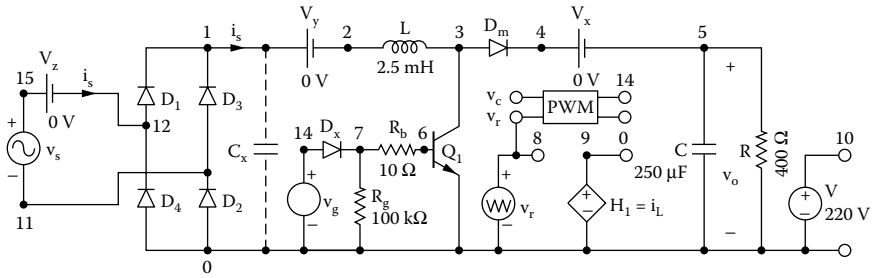


FIGURE 13.36 Diode rectifier with input current control.

**EXAMPLE 13.10 FINDING THE CLOSED-LOOP RESPONSE OF THE OUTPUT VOLTAGE FOR THE DIODE RECTIFIER–BOOST CONVERTER**

A diode rectifier followed by a boost converter is shown in Figure 13.36. The input voltage is  $v_s = 170 \sin(120\pi t)$ . The circuit is operated closed loop, so that the output voltage is  $V_o = 220 \pm 0.2$  V, and the input current is sinusoidal with an error of  $\pm 0.2$  A. Use PSpice to plot the transient response of output voltage  $v_o$  and the input current  $i_s$ .

The model parameters for the IGBT are:

TAU=287.56E9 KP=50.034 AREA=37.500E-6 AGD=18.750E6  
 VT=4.1822 KF=.36047 CGS=31.942E9 COXD=53.188E9  
 VTD=2.6570

The model parameters for the BJT are:

IS=2.33E-27 and BF=13

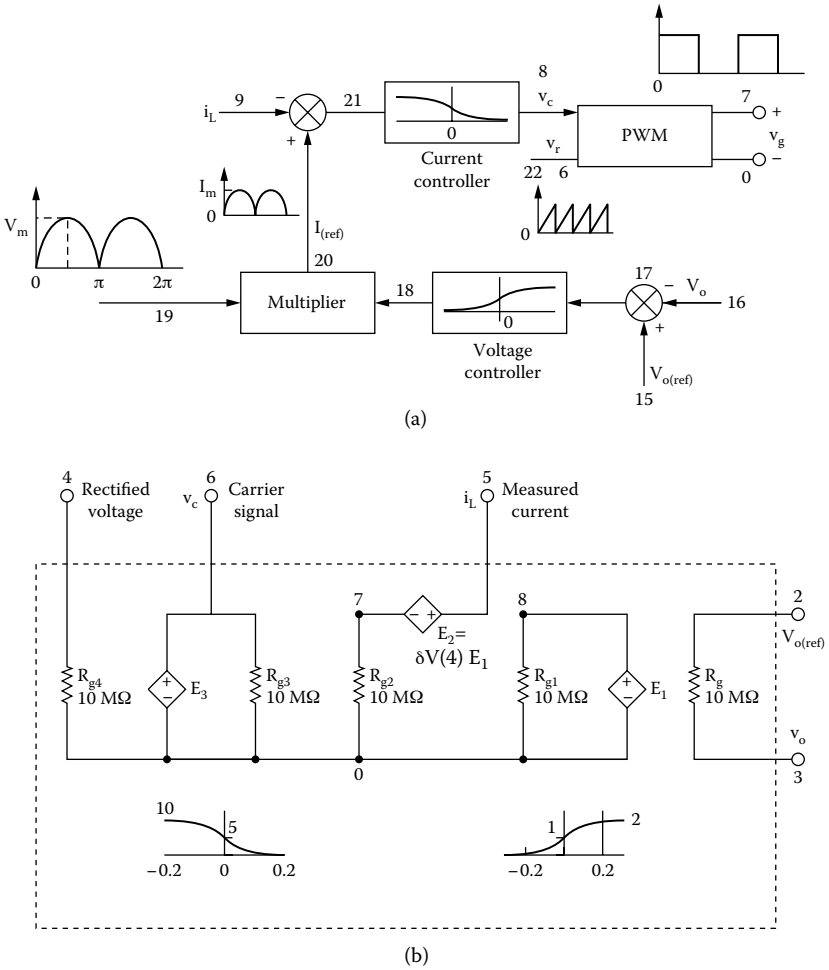
and those for the diode are:

IS=2.2E-15, BV=1200V, CJO=1PF, and TT=0.

**SOLUTION**

The peak input voltage is  $V_m = 170$  V. Assuming a diode drop of 1 V, the peak rectified voltage becomes  $170 - 2 = 168$  V. The input frequency is  $f = 60$  Hz. The block diagram for closed-loop control is shown in Figure 13.37(a). The error of the output voltage after passing through a controller generates the reference current for the current controller, whose output is the carrier signal for the PWM generator. Equating rectified output power to the load power, we get

$$V_{in(DC)} I_{in(DC)} = \frac{V_o^2}{R} \tag{13.8}$$



**FIGURE 13.37** Subcircuit CONTR current controller. (a) Block diagram for closed-loop control; (b) circuit for Pspice simulation of current controller.

Because for a rectified sine wave  $V_{(average)} = 2V_{(peak)}/\pi$ , Equation 13.8 becomes

$$\frac{2V_m}{\pi} \frac{2I_m}{\pi} = \frac{V_o^2}{R}$$

which gives the multiplication constant  $\delta$  as

$$\begin{aligned} \delta &= \frac{I_m}{V_m} = \frac{\pi^2 V_o^2}{4RV_m^2} \\ &= \frac{\pi^2 \times 220^2}{4 \times 400 \times 168^2} = 0.01 \end{aligned} \tag{13.9}$$

A value of  $\delta$  higher than 0.01 would increase the sensitivity and give better transient response. But the PWM generator will be operated in the overmodulation region if it is too high. Let us assume  $\delta = 0.05$ .

We use a proportional controller with an error band of  $\pm 1$ . The circuit for PSpice simulation of the current controller is shown in [Figure 13.37\(b\)](#). The multiplication is implemented with VALUE. The voltage and current controllers are implemented by TABLE.

The listing of the subcircuit CONTR for [Figure 13.37\(b\)](#) is as follows:

---

```
* Subcircuit definition for CONTR current controller:
.SUBCKT CONTR      2      3      4      5      6
*      model desired output rec. input input current carrier
*      name  voltage voltage  voltage  signal (voltage) signal
E1  8  0  TABLE{V(2,3)} =          ; Voltage controller
+   (-0.2, 2) (0, 1) (0.2, 0)
E2  5  7  VALUE = {0.05*V(4)*V(8)}  ; Reference current
E3  6  0  TABLE{V(7)} =          ; Current controller
+   (-0.2, 0) (0, 5) (0.2, 10)
.ENDS CONTR
```

---

The PWM subcircuit is implemented with an ABM, ABM2 with two inputs. The listing of the subcircuit PWM is as follows:

---

```
* Sub circuit definition PWM:
.SUBCKT PWM          1      2      3
*      model reference carrier output
*      name  voltage  signal  voltage
E_AB21  3      0      VALUE {IF(V(2)-V(1)>0, 10, 0)}
.ENDS PWM
```

---

Using 20 pulses per half cycle of the input voltage, the switching frequency of the PWM generator is  $f_s = 40 \times 60 = 2.4$  kHz, and the switching period is  $T_s = 416.67$   $\mu$ sec.

The PSpice schematic is shown in [Figure 13.38](#) for a unity power factor diode with a boost converter.

The listing of the circuit file for [Figure 13.38](#) is as follows:

**Example 13.10 Diode rectifier with PWM current control**

```

.PARAM Vo_ref=220V Freq=2.0kHz
Vr 8 0 PULSE (0 10 0 {1/({2*{Freq}})-1ns} 1ns 1ns {1/{2*{Freq}}}) ; Reference Signal
Vo_ref 16 0 DC {Vo_ref}
SOURCE ■ VS 4 11 SIN (0V 170V 60HZ)
CIRCUIT ■■ VZ 4 12 DC 0V ; Measures supply current
D1 12 1 DMOD ; Rectifier diodes
D2 0 11 DMOD
D3 11 1 DMOD
D4 0 12 DMOD
VY 1 2 DC 0V ; Voltage source to measure input current
H1 9 0 VY 0.034
Rg 6 0 100K
RB 7 6 250 ; Transistor base resistance
L 2 3 2.5MH
DM 3 4 DMOD ; Freewheeling diode
VX 4 5 DC 0V ; Voltage source to measure inductor current
R 5 0 100 ; Load resistance
C 5 0 250UF IC = 0V ; Load filter capacitor
.MODEL DMOD D(IS = 2.2E - 15 BV = 1200V CJO = 1PF TT = 0) ; Diode model parameters
.MODEL DM D(IS = 2.2E - 15 BV = 1200V CJO = 0 TT = 0) ; Diode model parameters
Z1 3 6 0 IXGH40N60 ; IGBT switch
* .MODEL IXGH40N60D NPN (IS=2.33E-27 BF=13)
.MODEL IXGH40N60 NIGBT (TAU=287.56E-9 KP=50.034
+ AREA=37.500E-6 + AGD=18.750E-6 VT=4.1822 KF=.36047
+ CGS=31.942E-9 COXD=53.188E-9 VTD=2.6570)
* Subcircuit call for PWM control:
XPW 8 13 10 PWM ;Control voltage for transistor Z1
* Subcircuit call for CONTR current controller:
XCONT 16 15 17 9 13 CONTR
* Subcircuit definition CONTR must be inserted.
* Subcircuit definition PWM must be inserted.
ANALYSIS ■■■ .TRAN 1US 35MS ; Transient analysis
.PROBE ; Graphics post-processor
.FOUR 60HZ I(VZ) ; Fourier analysis
.OPTIONS ABSTOL = 1.00U RELTOL = 0.01 VNTOL = 0.1
ITL5 = 0 ; Convergence
.END

```

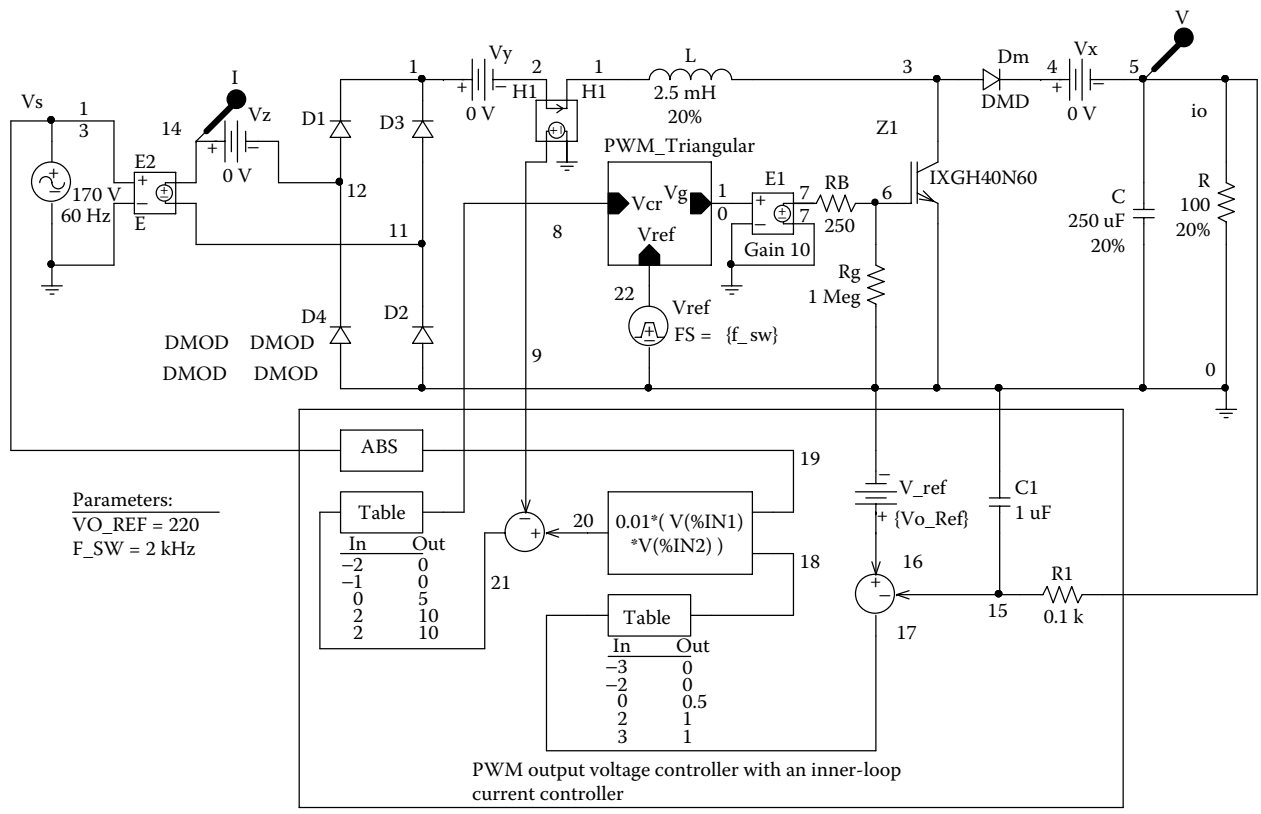


FIGURE 13.38 PSpice schematic for Example 13.10.

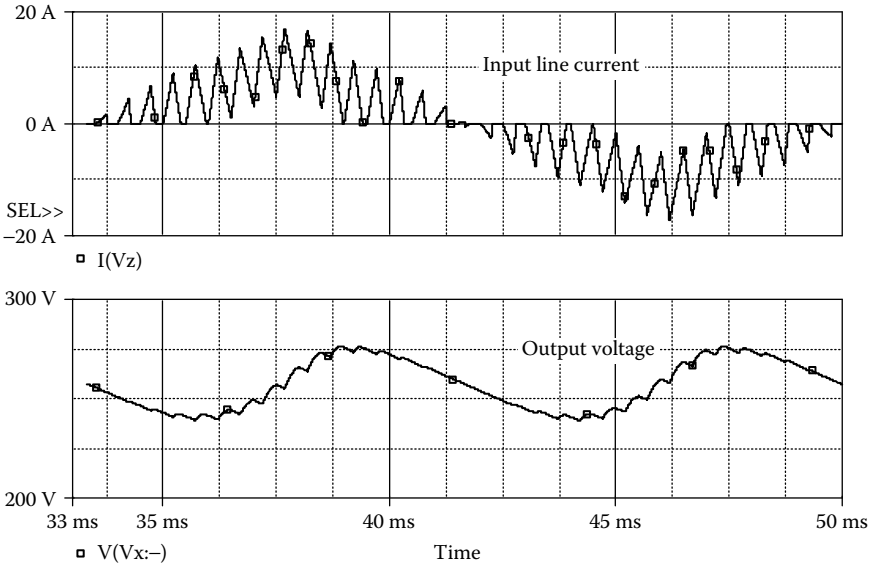
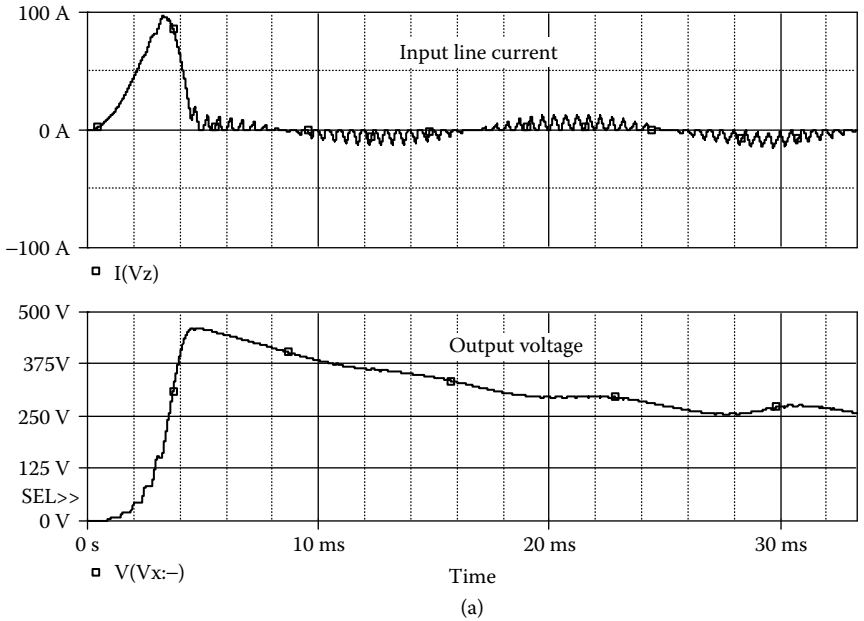
The plots of the output voltage  $V(5)$  and input current  $I(VZ)$  are shown in Figure 13.39(a). The expanded waveforms are shown in Figure 13.39(b). The current controller forces the input current to be in phase with the input supply voltage and to follow a sinusoidal reference current. This improves the input power factor. A small filter can remove the high-frequency components of the input current. The upper bound of the output voltage is limited by the proportional controller. It should be noted that the load voltage has not yet reached the steady-state condition. The lower limit depends on the time constant of the load circuit. It requires careful design to determine the values of  $L$  and  $C$ , the controller parameters, and the switching frequency. A proportional–integral (PI) controller, coupled with a large value for the load filter capacitor, should give faster response of the output voltage.

The Fourier components of the input current are as follows:

DC COMPONENT = 3.606477E-02					
Harmonic No	Frequency (Hz)	Fourier Component	Normalized Component	Phase (Deg)	Normalized Phase (Deg)
1	6.000E+01	8.195E+00	1.000E+00	2.291E+00	0.000E+00
2	1.200E+02	6.478E-02	7.905E-03	5.133E+01	5.591E+01
3	1.800E+02	2.039E+00	2.488E-01	1.678E+02	1.747E+02
4	2.400E+02	5.545E-02	6.766E-03	1.601E+02	1.509E+02
5	3.000E+02	7.729E-01	9.432E-02	3.090E+01	1.944E+01
6	3.600E+02	4.388E-02	5.354E-03	3.395E+01	2.020E+01
7	4.200E+02	2.740E-01	3.344E-02	1.189E+02	1.350E+02
8	4.800E+02	6.214E-02	7.582E-03	1.638E+02	1.455E+02
9	5.400E+02	8.967E-02	1.094E-02	1.693E+02	1.899E+02
10	6.000E+02	8.997E-02	1.098E-02	2.126E+01	4.417E+01
TOTAL HARMONIC DISTORTION = 2.689696E+01 PERCENT					

For  $THD = 26.89\%$  and  $\phi_1 = -2.291^\circ$ , Equation 7.3 gives the input power factor of the rectifier as

$$PF_1 = \frac{1}{\sqrt{1 + \left(\frac{\%THD}{100}\right)^2}} \cos \phi_1 = \frac{1}{\sqrt{1 + \left(\frac{26.89}{100}\right)^2}} \cos(-2.291^\circ) = 0.965 \text{ (lagging)}$$



**FIGURE 13.39** Output voltage and the input line current for Example 13.10. (a) Input line current and the output voltage, (b) expanded timescale of the input line current and the output voltage.

## SUGGESTED READING

1. *Linear Circuits: Operational Amplifier Macromodels*, Dallas, TX: Texas Instruments, 1990.
2. G. Boyle, B. Cohn, D. Pederson, and J. Solomon, Macromodeling of integrated circuit operational amplifiers, *IEEE Journal of Solid-State Circuits*, Vol. SC-9, No. 6, December 1974, pp. 353–364.
3. I. Getreu, A. Hadiwidjaja, and J. Brinch, An integrated-circuit comparator macromodel, *IEEE Journal of Solid-State Circuits*, Vol. SC-11, No. 6, December 1976, pp. 826–833.
4. S. Progozy, Novel applications of SPICE in engineering education, *IEEE Transactions on Education*, Vol. 32, No. 1, February 1990, pp. 35–38.
5. M. Kazerani, P.D. Ziogas, and G. Ioos, A novel active current wave shaping technique for solid-state input power factor conditioners, *IEEE Transactions on Industrial Electronics*, Vol. IE38, No. 1, 1991, pp. 72–78.
6. A.R. Prasad and P.D. Ziogas, An active power factor correction technique for three phase diode rectifiers, *IEEE Transactions on Power Electronics*, Vol. 6, No. 1, 1991, pp. 83–92.
7. A.R. Prasad, P.D. Ziogas, and S. Manias, A passive current wave shaping method for three phase diode rectifiers, *Proc. IEEE APEC-91 Conf Record* 1991, pp. 319–330.
8. Manjusha S. Dawande and Gopal K. Dubey, Programmable Input power factor correction method for switch-mode rectifiers, *IEEE Transactions on Power Electronics*, Vol. II, No. 4, 1996, pp. 585–591.

## PROBLEMS

### 13.1

A full-wave precision rectifier is shown in [Figure P13.1](#). The input voltage is  $v_i = 0.1 \sin(2000\pi t)$ . Plot the transient response of the output voltage for a duration of 0 to 1 msec in steps of 10  $\mu$ sec. The op-amp  $\mu$ A741 can be modeled as a macromodel as shown in [Figure 13.3](#). The supply voltages are  $V_{CC} = 12$  V and  $V_{EE} = 12$  V.

### 13.2

Plot the DC transfer characteristics for [Figure P13.2](#). The input voltage is varied from  $-10$  to  $+10$  V in steps of 0.1 V. The zener voltages are  $V_{Z1} = V_{Z2} = 6.3$  V. The op-amp, which is modeled by the circuit in [Figure 13.1\(a\)](#), has  $R_i = 2$  M $\Omega$ ,  $R_o = 75$   $\Omega$ ,  $C_1 = 1.5619$   $\mu$ F, and  $R_1 = 10$  k $\Omega$ .

### 13.3

A feedback-control system is shown in [Figure P13.3](#). The reference input  $v_r$  is the step voltage of 1 V. Use PSpice to plot the transient response of the output voltage for a duration of 0 to 10 sec in steps of 10 msec. The gain  $K$  is to be

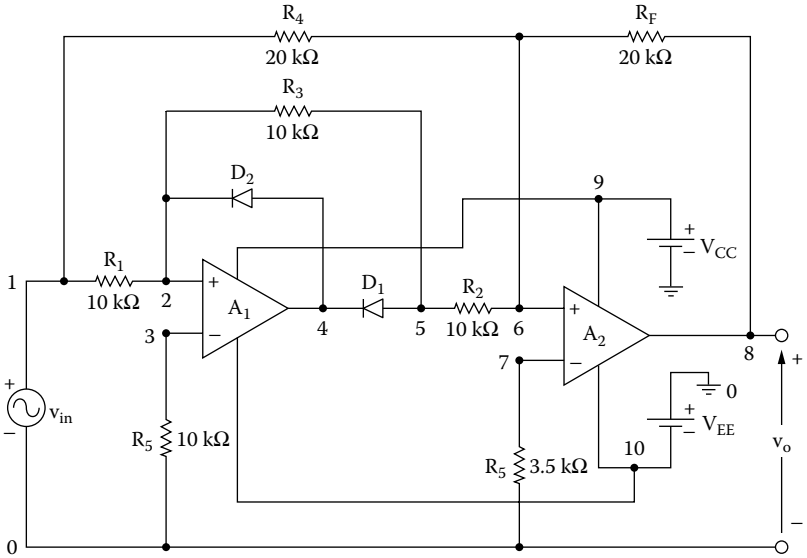


FIGURE P13.1 Full-wave precision rectifier.

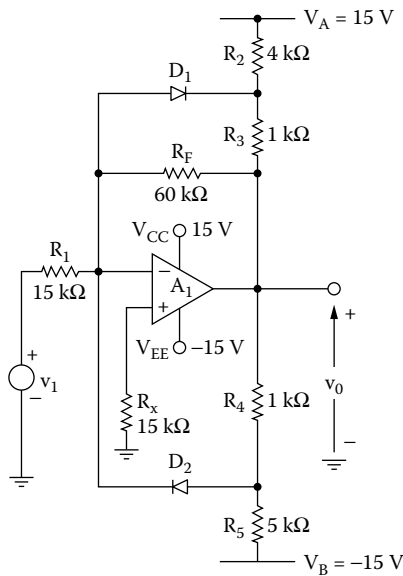


FIGURE P13.2 Op-amp limiting circuit.

varied from 0.5 to 2 with an increment of 0.5. Assume that all initial conditions are zero and that  $K_1 = 0.5$ .

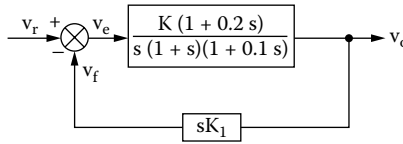


FIGURE P13.3 Feedback control system.

13.4

The constant  $\mu$  of Van der Pol’s equation is 4. Use PSpice to plot (a) the transient response of the output signal for a duration of 0 to 20 sec in steps of 10 msec, and (b) the phase plane ( $dy/dt$  against  $y$ ). Assume an initial disturbance of 1.

13.5

Repeat Example 13.9 for the  $i$  against  $V_{in}/H$  characteristic shown in Figure P13.5.

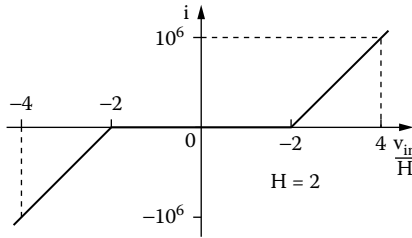


FIGURE P13.5 Backlash input signal.

13.6

Use PSpice to find the worst-case minimum and maximum output voltages  $V_{o(max)}$  and  $V_{o(min)}$  for Example 13.10. Assume uniform tolerances of  $\pm 15\%$  for all passive elements and an operating temperature of  $25^\circ\text{C}$ .

13.7

Repeat Example 13.10 for  $L = 5$  mH. What are the effects of increasing the value of  $L$  on the THD of the input current and the input power factor?

13.8

Repeat Example 13.10 for  $C_1 = 1$   $\mu\text{F}$  and  $R_1 = 1$   $\text{k}\Omega$ . What are the effects of increasing the time constant of the  $RC$  filter of the voltage feedback circuit?

---

# 14 Characteristics of Electrical Motors

The learning objectives of this chapter are:

- Modeling the characteristics of DC motors and specifying their model parameters
- Modeling the characteristics of induction motors and specifying their model parameters
- Performing transient analysis of electric motors
- Performing worst-case analysis of electric motors for parametric variations of model parameters and tolerances

## 14.1 INTRODUCTION

The PSpice simulation of power converters can be combined with the equivalent circuit of electrical machines to obtain their control characteristics. The machines can be represented in SPICE by a linear or nonlinear magnetic circuit or in a function or table form. We use linear circuit models to obtain:

DC motor characteristics  
Induction motor characteristics

## 14.2 DC MOTOR CHARACTERISTICS

The motor back emf is given by

$$E_g = K\omega I_f$$

and the developed motor torque

$$T_d = K I_a I_f$$

can be represented by polynomial sources. The torque  $T_d$  is related to the load torque  $T_L$  and motor speed  $\omega$  by

$$T_d = J \frac{d\omega}{dt} + B\omega + T_L$$

$$T_d - T_L - B\omega = J \frac{d\omega}{dt}$$

Thus, integrating the net torque will give the motor speed  $\omega$ , which after further integration gives the shaft position  $\theta$ . The behavioral models in PSpice allow performing many functions such as addition, subtraction, multiplication, integration, and differentiation.

#### EXAMPLE 14.1 FINDING THE PERFORMANCE OF A SEPARATELY EXCITED MOTOR CONTROLLED BY A DC–DC CONVERTER

The armature of a separately excited DC motor is controlled by a DC–DC converter operating at a frequency of  $f_c = 1$  kHz and a duty cycle of  $k = 0.8$ . The DC–DC supply voltage to the armature is  $V_s = 220$  V. The field current is also controlled by a DC–DC converter operating at a frequency of  $f_s = 1$  kHz and a duty cycle of  $\delta = 0.5$ . The DC supply voltage to the field is  $V_f = 280$  V. The motor parameters are:

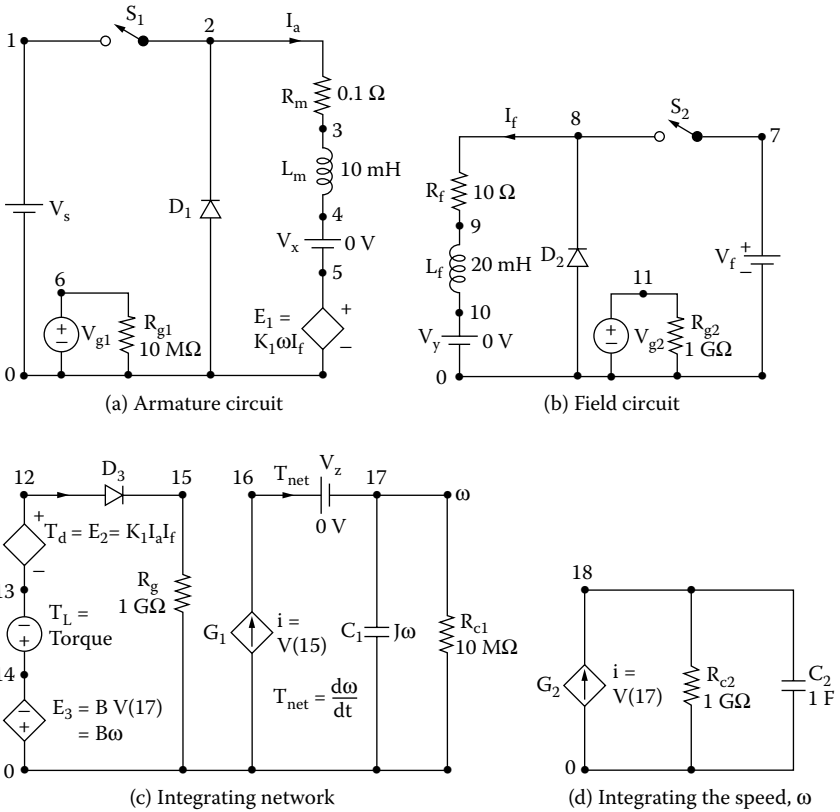
- Armature resistance,  $R_m = 0.1 \Omega$
- Armature inductance,  $L_m = 10$  mH
- Field resistance,  $R_f = 10 \Omega$
- Field inductance,  $L_f = 20$  mH
- Back-emf constant,  $K = 0.91$
- Viscous torque constant,  $B = 0.3$
- Motor inertia,  $J = 1$
- Load torque,  $T_L = 50, 100, \text{ and } 150$  N·m

Use PSpice to plot the transient response of the armature and field current, the torque developed, and the motor speed for a duration of 0 to 30 msec in steps of 10  $\mu$ sec.

#### SOLUTION

The armature and field circuits for PSpice simulation are shown in Figure 14.1(a) and Figure 14.1(b), respectively. The net torque, which is obtained by subtracting the viscous ( $T_B$ ) and load torque ( $T_L$ ) from the torque developed ( $T_d$ ), is integrated to obtain the motor speed as shown in Figure 14.1(c). The motor speed is integrated to obtain the shaft position as shown in Figure 14.1(d).

The PSpice schematic is shown in Figure 14.2, which comprises three separate blocks: the motor field, motor armature, and motor load consisting of inertia  $J$  and viscous torque constant  $B$ . It has one pulse-width modulated (PWM) generator for the armature control and one PWM generator for the motor field control. The listing of the circuit file is as follows:



**FIGURE 14.1** DC–DC converter-controlled DC motor for PSpice simulation. (a) Armature circuit, (b) field circuit, (c) integration network, (d) integrating the speed  $\omega$ .

**Example 14.1** DC separately excited motor with variable load torques

```

SOURCE ■ VS 1 0 DC 220V ; Armature supply
PARAM Duty_a=0.5 ; duty cycle of the armature circuit
.PARAM Duty_f=0.8 ; duty cycle of the field circuit
.PARAM Freq=1kHz ; switching frequency
.PARAM Km=0.1
Vg1 6 0 PULSE (0 20V 0 1ns 1ns {{Duty_a}/{Freq}-2ns}
{1/{Freq}})
Vg2 11 0 PULSE (0 20V 0 1ns 1ns {{Duty_f}/{Freq}-2ns}
{1/{Freq}})
Rg1 6 0 10MEG
VF 7 0 DC 280V ; Field supply
Rg2 11 0 10MEG
    
```

```

CIRCUIT ■■■ .PARAM VISCOUS = 0.3 ; Viscous constant
               .PARAM J = 1 ; Motor inertia
               .PARAM TL = 100 ; Load torque
               .STEP PARAM TL 50 150 50 ; Load torque varied
               S1  1  2  6  0 SMOD ; Voltage-controlled switch
               .MODEL SMOD VSWITCH (RON=0.01 ROFF=10E+6 VON=10V
               VOFF=5V)
               D1  0  2 DMOD
               .MODELDMODD (IS=2.2E-15 BV=1200V CJO=0 TT=0) ; Diode
               model parameters
               RM  2  3  0.1
               LM  3  4  10MH
               VX  4  5 DC  0V      ; Senses the armature current
               E1  5  0 VALUE = {{km} *V(17) *I(VY)}
               RF  8  9  10
               LF  9  10 20MH
               VY 10  0 DC  0V      ; Senses the field current
               S2  7  8 11  0 SMOD ; Voltage-controlled switch
               D2  0  8 DMOD
               E2 12 13 VALUE = {{km} *I(VX) *I(VY)} ; Torque developed
               VL 14 13 {TL}      ; Load torque
               E3  0 14 VALUE = {VISCOUS*V (17)} ; Viscous torque
               D3 12 15 DMOD
               Rg 15  0 1G
               G1  0 16 15  0 1    ; Net torque
               VZ 16 17 DC  0V    ; Measures the net torque
               C1 17  0 {J} IC=0V  ; Load inertia
               Rc1 17  0 1G
               G2  0 18 17  0 1    ; Velocity to position
               C2 18  0 1  IC=0V
               Rc2 18  0 1G
ANALYSIS ■■■ . TRAN 10US 30MS UIC  ; Transient analysis with
               initial condition
               . PLOT TRAN V(3) V(1) ; Prints on the output file
               . OPTIONS ABSTOL = 1.00N RELTOL = 0.01 VNTOL = 0.1
               ITL5 = 50000
               . PROBE                ; Graphics post-processor
               . END

```

---

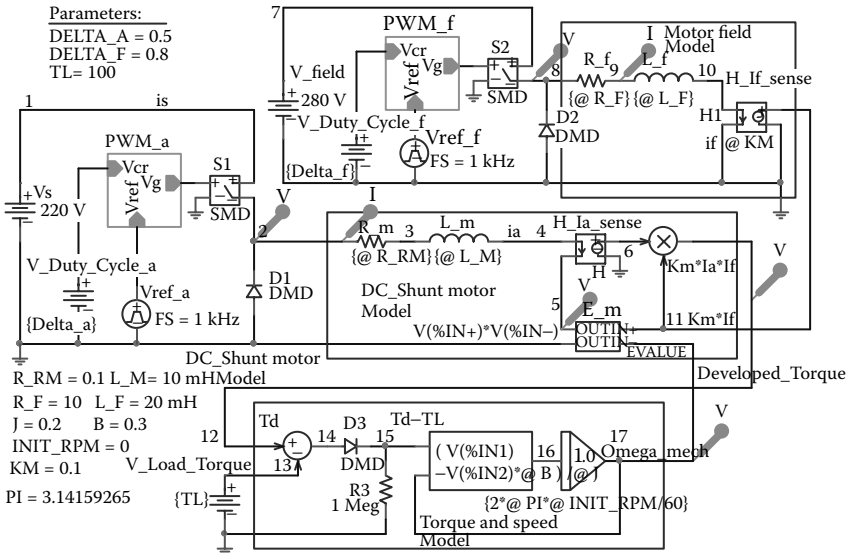


FIGURE 14.2 Plots of armature and field currents for Example 14.1.

The plots of the transient response for the armature  $I(VX)$  and field currents  $I(VY)$  are shown in Figure 14.3. The plots for the torque developed  $V(12,13)$  and the motor speed  $V(17)$  are shown in Figure 14.4. The field current shown has not reached steady-state conditions. The armature current reaches a peak before settling down. The torque is pulsating because of pulsating armature and field currents.

**EXAMPLE 14.2 FINDING THE PERFORMANCE OF A SEPARATELY EXCITED MOTOR WITH A STEP CHANGE IN LOAD TORQUE CONTROLLED BY A DC-DC CONVERTER**

Use PSpice to plot the transient response of the motor speed of Example 14.1 if the load torque  $T_L$  is subjected to a step change as shown in Figure 14.5.

**SOLUTION**

The PSpice schematic is similar to that shown in Figure 14.2, except that the load torque is a step pulse from 50 msec to 250 msec as shown in Figure 14.6. The listing of the circuit file is as follows:

**Example 14.2 DC separately excited motor with step load torque change**

```

SOURCE ■ VS 1 0 DC 220V ; Armature supply
.PARAM Duty_a=0.5 ; duty cycle of the armature circuit
.PARAM Duty_f=0.8 ; duty cycle of the field circuit
.PARAM Freq=1kHz ; switching frequency
.PARAM Km=0.1
    
```

```

Vg1 6 0 PULSE (0 20V 0 1ns 1ns { {Duty_a}/{Freq}-2ns}
{1/{Freq}}
Vg2 11 0 PULSE (0 20V 0 1ns 1ns { {Duty_f}/{Freq}-2ns}
{1/{Freq}}
Rg1 6 0 10MEG
VF 7 0 DC 280V ; Field supply
Rg2 11 0 10MEG

```

```

CIRCUIT ■■■ . PARAM VISCOUS = 0.3 J = 0.2 TL_min=150 TL_max = 250
S1 1 2 6 0 SMOD ; Voltage-controlled switch
. MODEL SMOD VSWITCH (RON = 0.01ROFF = 10E + 6VON =
10V VOFF = 5V ; Switch model
D1 0 2 DMOD
. MODEL DMOD D(IS = 2.2E-15BV = 1200VCJO = 0TT = 0) ;
Diode model parameters
RM 2 3 0.1
LM 3 4 35MH
VX 4 5 DC 0V ; Senses the armature current
E1 5 0 VALUE = {{km} *V(15) * I(VY)}
RF 8 9 10
LF 9 10 20MH
VY 10 0 DC 0V ; Senses the field current
S2 7 8 11 0 SMOD ; Voltage-controlled switch
D2 0 8 DMOD
E2 12 13 VALUE = {{km} *I(VX) *I(VY)} ; Torque
developed
VL 14 13 PULSE ({TL_min} {TL_max} 40MS 1NS 1NS 20MS
90MS) ; Load torque
E3 0 14 VALUE = {VISCOUS*V (17)} ; Viscous torque
D3 12 15 DMOD
Rg 15 0 1G
G1 0 16 15 0 1 ; Net torque
VZ 16 17 DC 0V ; Measures the net torque
C1 17 0 1 IC=0V
Rc1 17 0 1G
G2 0 18 17 0 1 ; Velocity to position
C2 18 0 1 IC=0V
Rc2 18 0 1G
ANALYSIS ■■■ .TRAN 10US 90MS UIC ; Transient analysis with initial
condition
. OPTIONS ABSTOL = 1.00N RELTOL = 0.01 VNTOL = 0.1
ITL5 = 0
. PROBE ; Graphics post-processor
. END

```

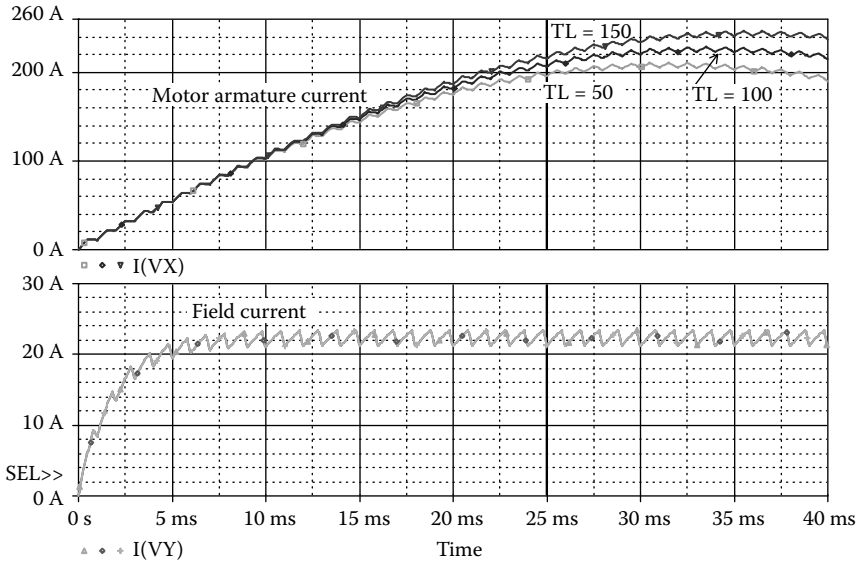


FIGURE 14.3 Plots of armature and field currents for Example 14.1

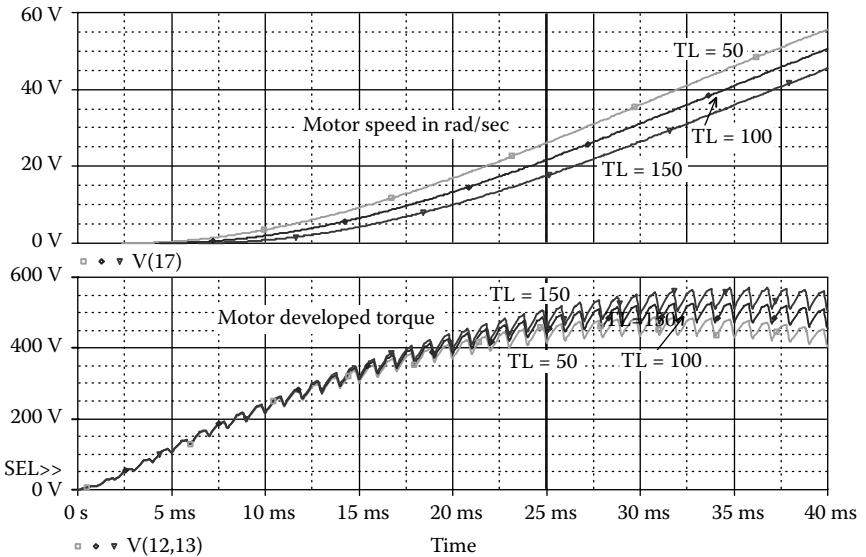


FIGURE 14.4 Motor speed and motor developed torque for Example 14.1.

The plots of the transient response of the load torque  $V(14,13)$  and the motor speed  $V(17)$  are shown in Figure 14.7. As expected, as increase in load torque slows down the speed rise.

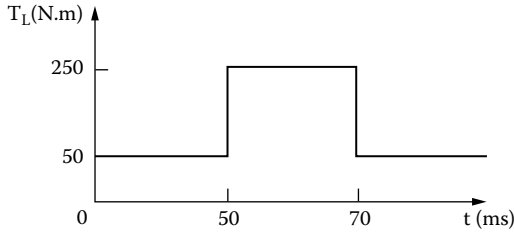


FIGURE 14.5 Step change of load torque.

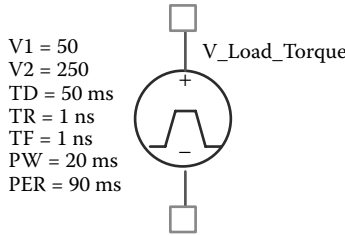


FIGURE 14.6 Step load torque for Example 14.2.

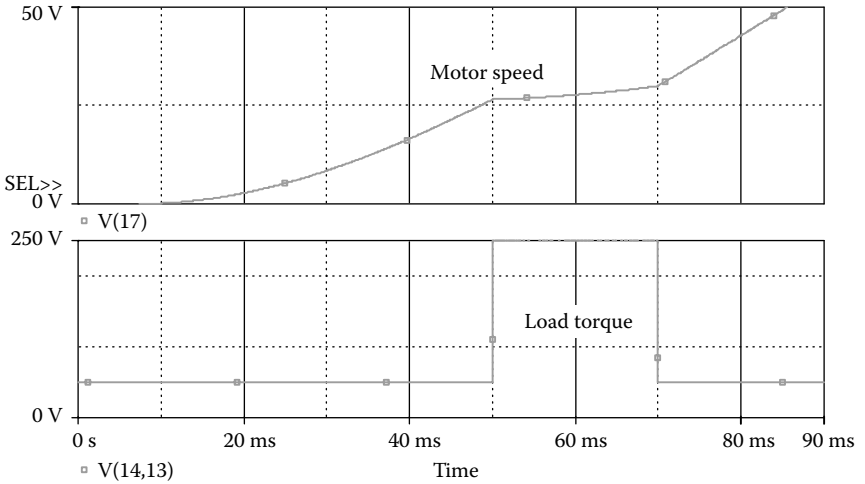


FIGURE 14.7 Plots of the load torque and the motor speed for Example 14.2.

### 14.3 INDUCTION MOTOR CHARACTERISTICS

PSpice can simulate the equivalent circuit of an induction motor and generator to determine their control characteristics. Parameters such as supply frequency,

rotor resistance, and rotor slip can be varied to find the effects of control variables on the performance of motor drives. An inverter that controls the motor voltage, current, and frequency can be added to the motor circuit to simulate an inverter-fed induction motor drive.

**EXAMPLE 14.3 FINDING THE TORQUE–SPEED CHARACTERISTIC OF AN INDUCTION MOTOR FOR VARYING SLIP**

The equivalent circuit of an induction motor is shown in Figure 14.8. Use PSpice to plot the torque developed against frequency for slip  $s = 0.1, 0.25, 0.5,$  and  $0.75$ . The supply frequency is to be varied from 0.1 to 100 Hz. The motor parameters are:

- Stator resistance,  $R_s = 0.42 \Omega$
- Stator inductance,  $L_s = 2.18 \text{ mH}$
- Rotor resistance,  $R_r = 0.42 \Omega$  (referred to stator)
- Rotor inductance,  $L_r = 2.18 \text{ mH}$  (referred to stator)
- Magnetizing inductance,  $L_m = 58.36 \text{ mH}$  (referred to stator)

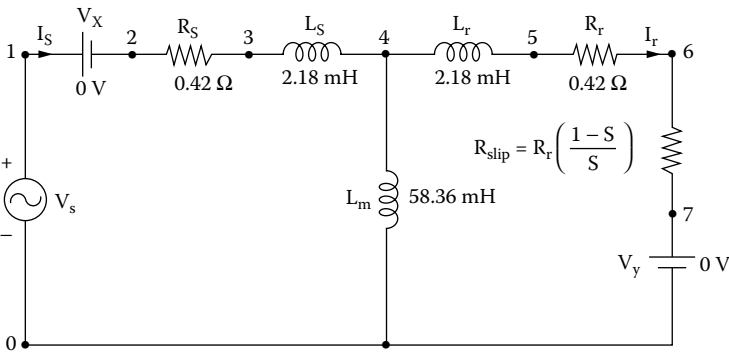
**SOLUTION**

The effective resistance due to slip is

$$R_{\text{slip}} = R_r \frac{1-s}{s}$$

By varying the slip,  $R_{\text{slip}}$ , the torque developed, and  $T_L$ , can be varied.

The PSpice schematic is shown in Figure 14.9. The slip is varied by using the PSpice parametric command .PARAM.



**FIGURE 14.8** Equivalent circuit for induction motor.

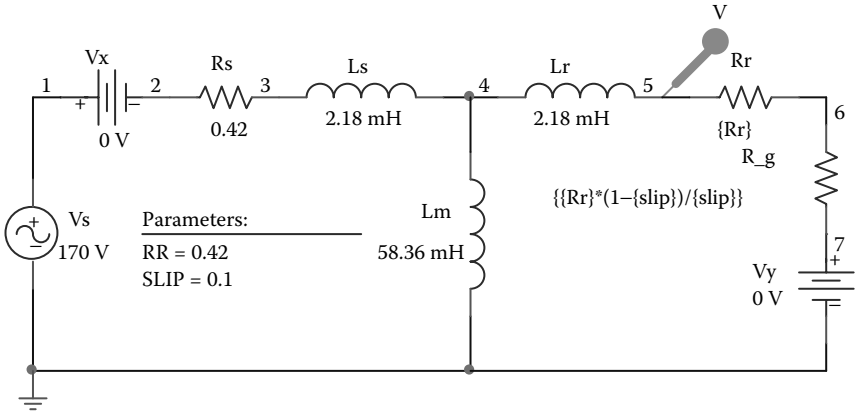


FIGURE 14.9 PSpice schematic for Example 14.3.

The listing of the circuit file is as follows:

### Example 14.3 Torque–speed characteristic of induction motor

**SOURCE** ■ VS 1 0 AC 170V ; input voltage of 170V

**CIRCUIT** ■■ .PARAM SLIP = 0.05 ; Slip

.PARAM RRES = 0.42 ; Rotor resistance

.PARAM Freq=1kHz ; switching frequency

.PARAMRSLIP = {RRES\* (1-slip)/slip}

.STEP PARAM SLIP LIST 0.1 0.25 0.5 0.75 ; Slip values

VX 1 2 DC 0V ; Senses the stator current

RS 2 3 {RRES}

LS 3 4 2.18MH

LM 4 0 58.36MH

LR 4 5 2.18MH

RR 5 6 {RRES}

RX 6 7 {RSLIP}

VY 7 0 DC 0V ; Senses the rotor current

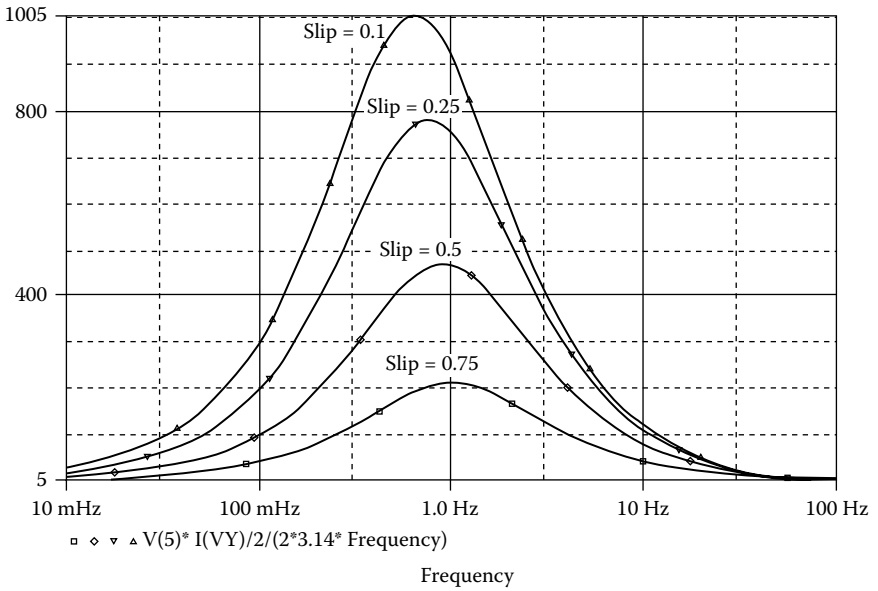
**ANALYSIS** ■■■ .AC DEC 100 0.1HZ 100HZ ; Ac analysis

.OPTIONS ABSTOL = 1.00N RETOL = 0.1 VNTOL = 0.1 ITL5 = 0

.PROBE ; Graphics post-processor

. END

The plots of the torque developed  $T_d = V(5) \times I(Vy)/2/(2 \times 3.14 \times \text{Frequency})$  vs. frequency for various slips are shown in Figure 14.10. The torque developed increases as the slip is reduced. For a fixed slip, there is a region of constant torque.



**FIGURE 14.10** Plots of the developed torque vs. frequency for Example 14.3.

**EXAMPLE 14.4 FINDING THE TORQUE–SPEED CHARACTERISTIC OF AN INDUCTION MOTOR FOR VARYING ROTOR RESISTANCE**

Repeat Example 14.3 for rotor resistance  $R_r = 0.1 \Omega, 0.2 \Omega, 0.3 \Omega,$  and  $0.42 \Omega$ . The slip is kept fixed at  $s = 0.1$ .

**SOLUTION**

The PSpice schematic is similar to that as shown in Figure 14.9. The rotor resistance is varied by using the PSpice parametric command .PARAM.

The listing of the circuit file is as follows:

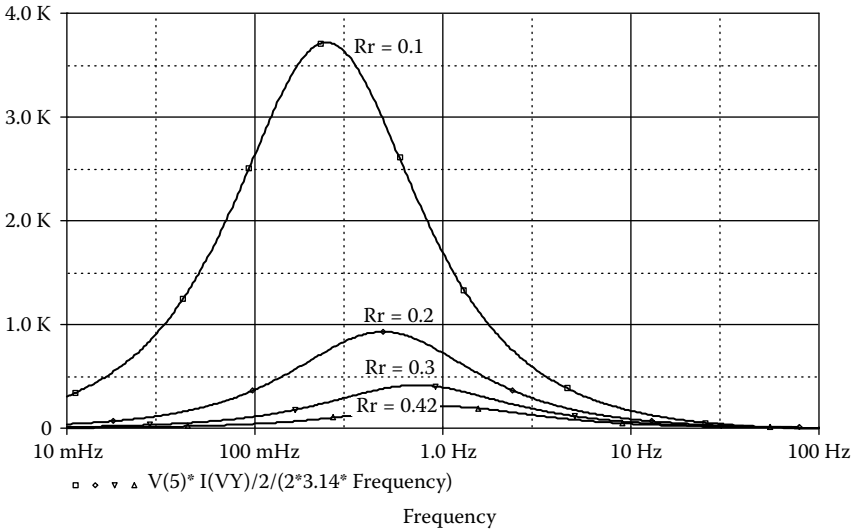
**Example 14.4 Torque–speed characteristic with variable rotor resistance**

```

SOURCE      ■ VS 1 0 AC 170V                ; Input voltage of 170V
CIRCUIT     ■■ .PARAM SLIP = 0.1            ; Slip
              .PARAM RRES = 0.42           ; Rotor resistance
              .PARAM RSLIP = {RRES* (1-slip)/slip}
              .STEP PARAM RRES LIST 0.1 0.2 0.3 0.42 ; List values
              VX 1 2 DC 0V                  ; Senses the stator current
              RS 2 3 {RRES}
              LS 3 4 2.18MH
    
```

```

LM 4 0 58.36MH
LR 4 5 2.18MH
RR 5 6 {RRES}
RX 6 7 {RSLIP}
VY 7 0 DC 0V ; Senses the rotor current
ANALYSIS ■■■ .AC DEC 100 0.1HZ 100HZ ; AC analysis
.OPTIONS ABSTOL = 1.00N RELTOL = 0.01 VNTOL = 0.1
ITL5 = 0
.PROBE ; Graphics post-processor
.END
    
```



**FIGURE 14.11** Plots of the developed torque vs. frequency for Example 14.4.

The plots of the torque developed  $T_d = V(5) \times I(Vy) / (2 \times 3.14 \times \text{Frequency})$  vs. frequency for various slips are shown in Figure 14.11. The torque increases as the rotor resistance is reduced.

**SUGGESTED READING**

1. J.F. Lindsay and M.H. Rashid, *Electromechanics and Electrical Machinery*, Englewood Cliffs, NJ: Prentice Hall, 1986.
2. Y.C. Liang and V.J. Gosbel, DC machine models for SPICE2 simulation. *IEEE Transactions on Power Electronics*, Vol. 5, No. 1, January 1990, pp. 16–20.
3. M.H. Rashid, *Power Electronics: Circuits, Devices, and Applications*, 3rd ed. Englewood Cliffs, NJ: Prentice Hall, 2003.
4. Alex E. Emanuel, Electromechanical transients simulations by means of PSpice, *IEEE Transactions on Power Systems*, Vol. PES, No.1, 1991, pp. 72–78.

5. M. Giesselmann and N. Mohan, Advanced Simulation of Motor Drives and Power Electronics using PSpice, Tutorial #3, 1998 IAS Annual Meeting, St. Louis, Missouri, October 12, 1998, pp. 1–64.
6. J. Rivas, J.M. Zamarro, E. Martin, and C. Pereira, Simple approximation for magnetization curves and hysteresis loops, *IEEE Transactions on Magnetics*, Vol. MAG-17, No.4, 1981, pp. 1498–1502.
7. Kenneth H. Carpenter, Using Spice to Solve Coupled Magnetic/Electric Circuit Problems, 26th North American Power Symposium, September 26–27, 1994, pp. 147–150.

## PROBLEMS

### 14.1

The DC–DC converter of [Figure 14.1\(a\)](#) is operating at a frequency of  $f_c = 2$  kHz and a duty cycle of  $k = 0.75$ . The DC supply voltage to the armature is  $V_s = 220$  V. The field current is also controlled by a DC–DC converter operating at a frequency of  $f_s = 2$  kHz and a duty cycle of  $\delta = 0.75$ . The DC supply voltage to the field is  $V_f = 220$  V. The motor parameters are:

- Armature resistance,  $R_m = 1 \Omega$
- Armature inductance,  $L_m = 5$  mH
- Field resistance,  $R_f = 10 \Omega$
- Field inductance,  $L_f = 10$  mH
- Back-emf constant,  $K = 0.91$
- Viscous torque constant,  $B = 0.4$
- Motor inertia,  $J = 0.8$
- Load torque,  $T_L = 10, 100, 200$  N·m

Use PSpice to plot the transient response of (a) the armature and field currents, (b) the torque developed, and (c) the motor speed for a duration of 0 to 4 msec in steps of 10  $\mu$ sec.

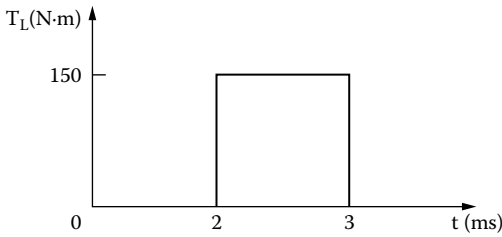
### 14.2

Use PSpice to plot the transient response of motor speed in Problem 14.1 if the load torque is subjected to a step change as shown in [Figure P14.2](#).

### 14.3

The parameters of the induction motor equivalent circuit shown in [Figure 14.8](#) are:

- Stator resistance,  $R_s = 1.01 \Omega$
- Stator inductance,  $L_s = 3.4$  mH
- Rotor resistance,  $R_r = 0.69 \Omega$  (referred to stator)
- Rotor inductance,  $L_r = 5.15$  mH (referred to stator)
- Magnetizing inductance,  $L_m = 115.4$  mH (referred to stator)



**FIGURE P14.2** Step torque change.

Use PSpice to plot the torque developed vs. frequency for slip  $s = 0.1, 0.20, 0.4,$  and  $0.6$ . The supply frequency is to be varied from  $0.1$  to  $200$  Hz.

#### 14.4

Repeat Problem 14.3 for a rotor resistances of  $R_r = 0.1, 0.2, 0.5,$  and  $0.69 \Omega$ . The slip is kept fixed at  $s = 0.15$ .

#### 14.5

Use PSpice to find the worst-case minimum and maximum motor torque  $T_{d(\max)}$  and  $T_{d(\min)}$ , and motor speed  $\omega_{m(\max)}$  and  $\omega_{m(\min)}$ , for Example 14.1. Assume uniform tolerances of  $\pm 15\%$  for all passive elements and an operating temperature of  $25^\circ\text{C}$ .

#### 14.6

Use PSpice to find the worst-case minimum and maximum motor developed torque  $T_{d(\max)}$  and  $T_{d(\min)}$  for Example 14.3. Assume uniform tolerances of  $\pm 15\%$  for all passive elements and an operating temperature of  $25^\circ\text{C}$ .

---

# 15 Simulation Errors, Convergence Problems, and Other Difficulties

The learning objectives of this chapter are to develop the following abilities:

- Familiarizing oneself with common types of simulation errors in SPICE and how to overcome them
- Handling convergence problems that are common in PSpice, especially in circuits with rapidly switching voltages or currents or both
- Using the options setup and their values

## 15.1 INTRODUCTION

An input file may not run for various reasons, and it is necessary to know what to do when the program does not work. To run a program successfully requires knowledge of what would not work and why, and how to fix the problem. There could be many reasons why a program does not work, and in this chapter we cover the commonly encountered problems and their solutions. The problems could be due to one or more of the following:

- Large circuits
- Running multiple circuits
- Large outputs
- Long transient runs
- Convergence
- Analysis accuracy
- Negative component values
- Power-switching circuits
- Floating nodes
- Nodes with fewer than two connections
- Voltage source and inductor loops

## 15.2 LARGE CIRCUITS

The entire description of an input file must fit into RAM during the analysis. However, the analysis results are not stored in RAM. All results (including intermediate results for the .PRINT and .PLOT statements) go to the output file

or one of the temporary files. Therefore, whether the run would fit into RAM depends on how big the input file is.

The size of an input file can be found by using the ACCT option in the .OPTIONS statement and looking at the MEMUSE number printed at the end of runs that terminate successfully. MEMUSE denotes the peak memory use of the circuit. If the circuit file does not fit into RAM, the possible remedies are:

1. Break up the file into pieces, and run them separately.
2. Reduce the amount of memory taken up by other resident software (e.g., DOS, utilities). The total memory available can be checked by the DOS command CHKDSK.
3. Buy more memory (up to 640 kilobytes, the most PCDOS recognizes).

### 15.3 RUNNING MULTIPLE CIRCUITS

A set of circuits may be run as a single job by putting all of them into one input file. Each circuit begins with a title statement and ends with a .END command, as usual. PSPICE1.EXE will read all the circuits in the input file and process them in sequence. The output file will contain the outputs from each circuit in the same order as they appear in the input file. This technique is most suitable for running a set of large circuits overnight, especially with SPICE or the professional version of PSpice. However, Probe can be used in this situation, because only the results of the last circuit will be available for graphical output by Probe.

### 15.4 LARGE OUTPUTS

A large output file will be generated if an input file is run with several circuits, or for several temperatures, or with sensitivity analysis. This will not be a problem with a hard disk. For a PC with floppy disks, the diskette may not be able to accommodate the output file. The best solution is to:

1. Direct the output to a printer instead of a file, or
2. Direct the output to an empty diskette instead of the one containing PSPICE1.EXE by assigning the PSpice programs to drive A: and the input and output files to drive B:. The command to run a circuit file would be

```
A: PSPICEB:EX2-1. CIRB: EX2-1.OUT
```

It is recommended that SPICE be run on a hard disk.

*Note:* Direct the output to the hard drive, if possible.

### 15.5 LONG TRANSIENT RUNS

Long transient analysis runs can be avoided by choosing the appropriate limit options. The limits that affect transient analysis are:

1. Number of print steps in a run, LIMPTS
2. Number of total iterations in a run, ITL5
3. Number of data points that Probe can handle

The number of print steps in a run is limited to the value of the LIMPTS option. It has a default value of 0 (meaning no limit) but can be set to a positive value as high as 32,000 (e.g., `.OPTIONS LIMPTS=6000`). The number of print steps is simply the final analysis time divided by the print interval time (plus one). The size of the output file that is generated by PSpice can be limited if errors occur, by using the LIMPTS option.

The total number of iterations in a run is limited to the value of the ITL5 option. It has a default value of 5000 but can be set as high as  $2 \times 10^9$  (e.g., `.OPTIONS ITL5=8000`). The limit can be turned off by setting `ITL5 = 0`. This is the same as setting ITL5 to infinity and is often more convenient than setting it to a positive number. It is advisable to set `ITL5=0`.

Probe limits the data points to 16,000. This limit can be overcome by using the third parameter on the `.TRAN` statement to suppress part of the output at the beginning of the run. For a transient analysis from 0 to 10 msec in steps of 100  $\mu$ sec and printing output from 8 to 10 msec, the command would be

```
.TRAN 10US 10MS 8MS
```

*Note.* The limit options from [Table 6.1](#) and [Table 6.2](#) can be typed into the circuit file as an `.OPTIONS` command. Alternatively, the limit options can be set from the Change Options menu, in which case PSpice would write these options into the circuit file automatically.

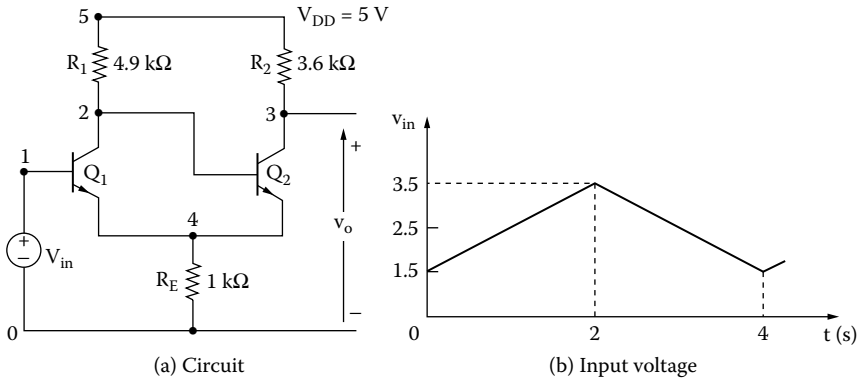
## 15.6 CONVERGENCE

PSpice uses iterative algorithms. These algorithms start with a set of node voltages, and each iteration calculates a new set, which is expected to be closer to a solution of Kirchhoff's voltage and current laws. That is, an initial guess is used and the successive iterations are expected to converge to the solution. Convergence problems may occur in:

- DC sweep
- Bias-point calculation
- Transient analysis

### 15.6.1 DC SWEEP

If the iterations do not converge to a solution, the analysis fails. The DC sweep skips the remaining points in the sweep. The most common cause of failure of the DC sweep analysis is an attempt to analyze a circuit with regenerative feedback, such as a Schmitt trigger. The DC sweep is not appropriate for calculating the hysteresis of such circuits, because it is required to jump discontinuously from one solution to another at the crossover point.



**FIGURE 15.1** Schmitt trigger circuit. (a) Circuit, (b) input voltage.

To obtain the hysteresis characteristics, it is advisable to use transient analysis with a piecewise linear (PWL) voltage source to generate a very slowly rising ramp. There is no CPU-time penalty for this, because PSpice will adjust the internal time step to be large away from the crossover point and small close to it. A very slow ramp ensures that the switching time of the circuit will not affect hysteresis levels. This is similar to changing the input voltage slowly until the circuit switches. With a PWL source in transient analysis, the hysteresis characteristics due to upward and downward switching can be calculated.

### EXAMPLE 15.1 FINDING THE HYSTERESIS CHARACTERISTIC OF AN EMITTER-COUPLED CIRCUIT

An emitter-coupled Schmitt trigger circuit is shown in Figure 15.1(a). Plot the hysteresis characteristics of the circuit from the results of transient analysis. The input voltage, which is varied slowly from 1.5 to 3.5 V and from 3.5 to 1.5 V, is as shown in Figure 15.1(b). The model parameters of the transistors are  $IS = 2.33E-27$ ,  $BF = 13$ ,  $CJE = 1PE$ ,  $CJC = 607.3PF$ , and  $TF = 26.5NS$ . Print the job statistical summary of the circuit.

#### SOLUTION

The input voltage is varied very slowly from 1.5 to 3.5V and from 3.5 to 1.5V as shown in Figure 15.1(b).

The PSpice schematic is shown in Figure 15.2(a). The ACCT option is selected from the Options menu as shown in Figure 15.2(b).

The listing of the circuit file is as follows:

---

### Example 15.1 Emitter-coupled trigger circuit

```
SOURCE  ■ VDD 5 0 DC 5V ; DC supply voltage of 5V
        VIN 1 0 PWL (0 1.5V 2 3.5V 4 1.5V) ; PWL waveform
```

```

CIRCUIT ■■ R1 5 2 4.9K
              R2 5 3 3.6K
              RE 4 0 1K
              Q1 2 1 4 4 2N6546      ; Transistor Q1
              Q2 3 2 4 4 2N6546      ; Transistor Q2
              .MODEL 2N6546 NPN (IS=2.33E-27 BF=13 CJE=1PF CJC=607.3PF
              TF=26.5NS)
              .OPTIONS ACCT           ; Printing the accounts summary
ANALYSIS ■■■ .TRAN 0.01 4          ; Transient analysis form 0
              to 4 s in steps of 0.01 s
              .PROBE                   ; Graphics post-processor
              .END

```

The hysteresis characteristic for Example 15.1 is shown in [Figure 15.3](#). The default x axis for transient analysis is time. The x-axis setting as shown in [Figure 15.3](#) is changed from the x-axis setting of the Plot menu in Probe. The job statistical summary, which is obtained from the output file, is as follows:

---

```

*** JOB STATISTICS SUMMARY
  NUNODS  NCNODS  NOMNOD  NUMEL  DIODES    BJTS    JFETS    MFETS  GASFETS
    6      6      6      7      0          2      0      0      0
NDIGITAL  NSTOP   NTTAR   NTTBR  NTTOV   IFILL   IOPS   PERSPA
    0      8      23     23     54      0      36    64.063
  NUMTTP  NUMRTP  NUMNIT  DIGTP  DIGEVT  DIGEVL  MEMUSE
    210    40     896     0      0      0      9914

```

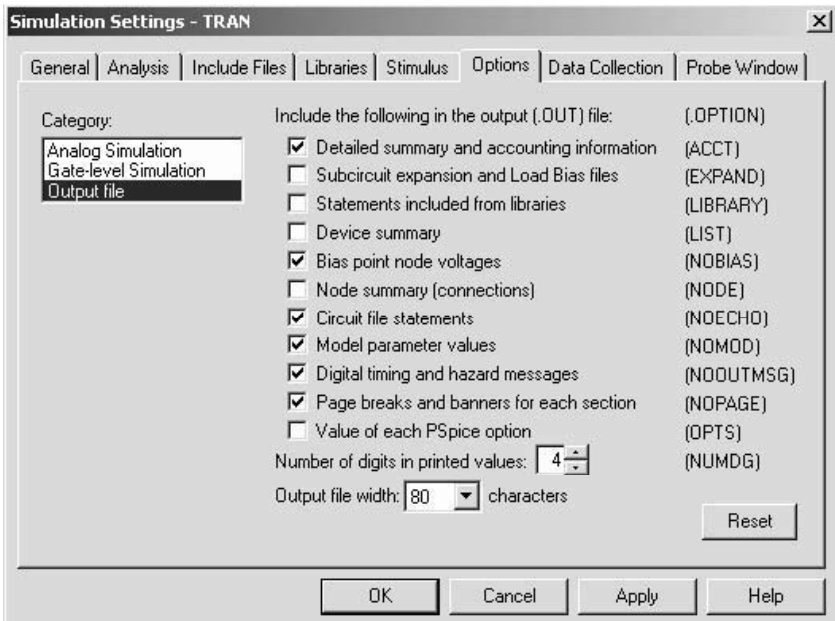
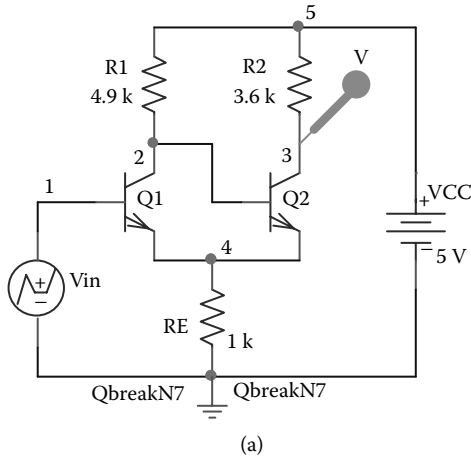
---

	SECONDS	ITERATIONS
MATRIX SOLUTION	.77	5
MATRIX LOAD	4.42	
READIN	.50	
SETUP	.11	
DC SWEEP	0.00	0
BIAS POINT	.99	92
AC and NOISE	0.00	0
TRANSIENT ANALYSIS	9.56	896
OUTPUT	0.00	
TOTAL JOB TIME	10.54	

---

### 15.6.2 BIAS-POINT CALCULATION

Failure of the bias-point calculation precludes other analyses (e.g., AC analysis, sensitivity, etc.). The problems in calculating the bias point can be minimized by the .NODESET statement [e.g., .NODESET V(1) = 0V]. If PSpice is given “hints”



**FIGURE 15.2** PSpice schematic for Example 15.1 (a) Schematic, (b) setup for enabling ACCT.

in the form of initial guesses for node voltages, it will start out that much closer to the solution. A little judgment must be used in assigning appropriate node voltages. In PSpice Schematics, the node voltage can be set at a specific voltage as shown in [Figure 15.4\(a\)](#) within the library special.slb as shown in [Figure 15.4\(b\)](#).

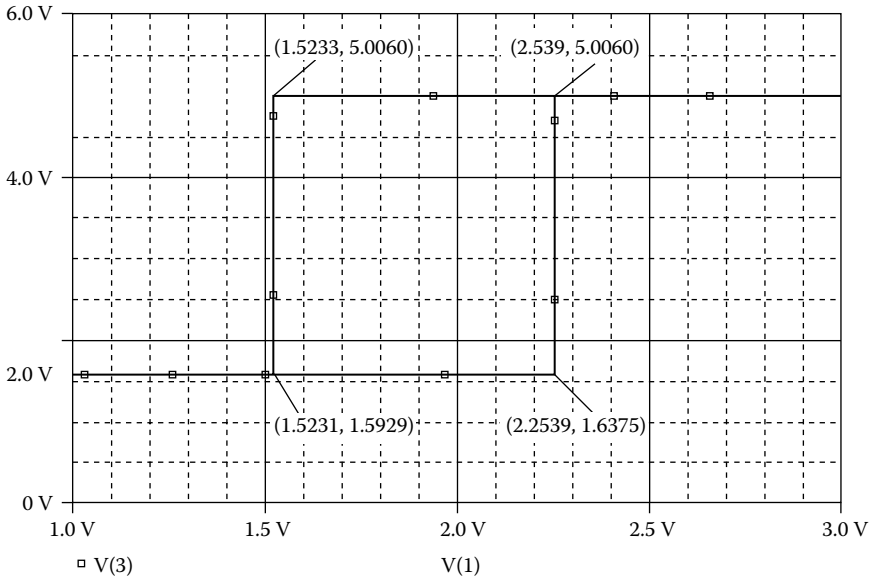


FIGURE 15.3 Hysteresis characteristics for Example 15.1

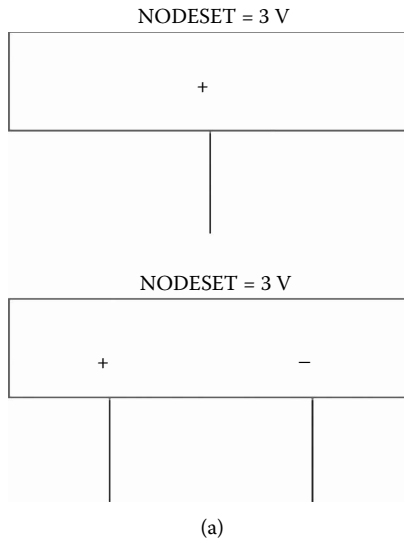
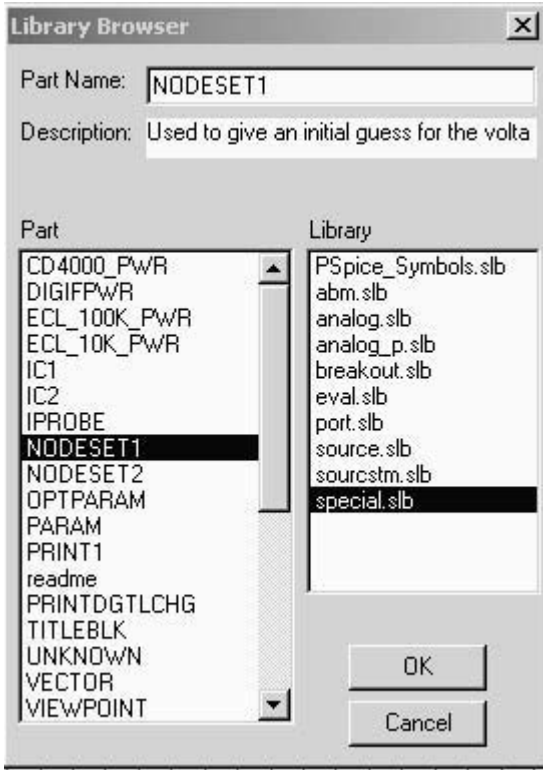


FIGURE 15.4 Setup for node voltages (a) Node voltages, (b) setup for node set.

It is rare to have a convergence problem in the bias-point calculation. This is because PSpice contains an algorithm to scale the power supplies automatically if it has trouble finding a solution. This algorithm first tries to find a bias point with the power supplies at full scale. If there is no convergence, the power supplies



(b)

**FIGURE 15.4** (continued).

are cut back to  $\pi$ th strength, and the program tries again. If there is still no convergence, the supplies are cut by another factor of 4 to  $1/16$ th strength, and so on. At power supplies of 0 V, the circuit definitely has a solution with all nodes at 0 V, and the program will find a solution for some supply value scaled far enough back. It then uses that solution to help it work its way back up to a solution with the power supplies at full strength. If this algorithm is in effect, a message such as

Power supplies cut back to 25%

(or some other percentage) appears on the screen while the program calculates the bias point.

### 15.6.3 TRANSIENT ANALYSIS

In the case of failure due to convergence, the transient analysis skips the remaining time. The few remedies that are available for transient analysis are:

1. To change the relative accuracy RELTOL from 0.001 to 0.01
2. To set the iteration limits at any point during transient analysis using the option ITL4. Setting ITL4 = 50 (by the statement `OPTIONS ITL4=50`) will allow 50 iterations at each point. As a result of more iteration points, a longer simulation time will be required. It is not recommended for circuits that do not have a convergence problem in transient analysis.

## 15.7 ANALYSIS ACCURACY

The accuracy of PSpice's results is controlled by the parameters RELTOL, VNTOL, ABSTOL, and CHGTOL in the .OPTIONS statement. The most important of these is RELTOL, which controls the relative accuracy of all the voltage and currents that are calculated. The default value of RELTOL is 0.001 (0.1%).

VNTOL, ABSTOL, and CHGTOL set the best accuracy for the voltages, currents, and capacitor charges/inductor fluxes, respectively. If a voltage changes its sign and approaches zero, RELTOL will force PSpice to calculate more accurate values of that voltage because 0.1% of its value becomes a tighter and tighter tolerance. This would prevent PSpice from ever letting the voltage cross zero. To prevent this problem, VNTOL can limit the accuracy of all voltages to a finite value, and the default value is 1  $\mu$ V. Similarly, ABSTOL and CHGTOL can limit the currents and charges (or fluxes), respectively.

The default values for the error tolerances in PSpice are the same as in Berkeley SPICE2. However, they differ from that of the commercial HSpice program, as shown in Table 15.1. RELTOL = .001 (0.1%) is more accurate than is necessary for many applications. The speed can be increased by setting RELTOL = 0.01 (1%), and this would increase the average speed-up by a factor of 1.5. In most power electronics circuits, the default values can be changed without affecting the results significantly.

*Note:* The limit options from Table 6.1 can be typed into the circuit file as an .OPTIONS command. Alternatively, the limit options can be set from the Change Options menu, in which case PSpice would write these options into the circuit file automatically.

---

**TABLE 15.1**  
**Tolerances**

	PSpice	SPICE2	HSpice
RELTOL	0.001	0.001	0.01
VNTOL	1 $\mu$ V	1 $\mu$ V	50 $\mu$ V
ABSTOL	1 $\mu$ A	1 $\mu$ A	1 nA

---

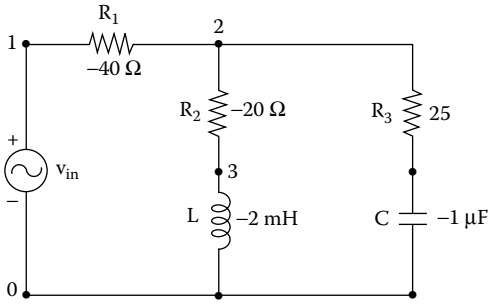


FIGURE 15.5 Circuit with negative components.

## 15.8 NEGATIVE COMPONENT VALUES

PSpice allows negative values for resistors, capacitors, and inductors. It should calculate a bias point or DC sweep for such a circuit. The .AC and .NOISE analyses can handle negative components. In the case of resistors, their noise contribution comes from their absolute values, and the components are not allowed to generate negative noise. However, negative components, especially negative capacitors and inductors, may cause instabilities in time, and the transient analysis may fail for a circuit with negative components.

### EXAMPLE 15.2 TRANSFER FUNCTION ANALYSIS OF A CIRCUIT WITH A NEGATIVE RESISTOR

A circuit with negative components is shown in Figure 15.5. The input voltage is  $V_{in} = 120$  V (peak), 60 Hz. Use PSpice to calculate the currents  $I(R1)$ ,  $I(R2)$ , and  $I(R3)$  and the voltage  $V(2)$ .

#### SOLUTION

The PSpice schematic with a negative resistance is shown in [Figure 15.6](#).

The listing of the circuit file is as follows:

---

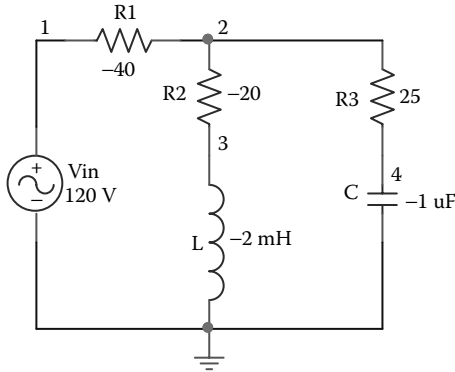
#### Example 15.2 Circuit with negative components

```

SOURCE  ■ VIN 1 0 AC 120V          ; AC input voltage of 120 V
CIRCUIT ■■ R1 1 2 -40             ; Negative resistances
          R2 2 3 -20
          R3 2 4 25
          L 3 0 -2MH              ; Negative inductance
          C 4 0 -1UF             ; Negative capacitance
ANALYSIS ■■■ .AC LIN 1 60HZ 60HZ ; AC analysis
          .PRINT AC 1M(R1) IM(R2) IM(R3) VM(2)
          .END

```

---



**FIGURE 15.6** PSpice schematic for Example 15.3.

The results of PSpice simulation are as follows:

****	AC ANALYSIS		TEMPERATURE = 27.000 DEG C	
FREQ	IM(R1)	IP(R1)	VM(2)	VP(2)
6.000E+01	2.000E+00	1.794E+02	4.003E+01	1.151E+00
JOBCONCLUDED				
TOTAL JOB TIME			1.26	

## 15.9 POWER SWITCHING CIRCUITS

The SPICE program was developed to simulate integrated circuits containing many small, fast transistors. Because of the integrated-circuit emphasis, the default values of the overall parameters are not optimal for simulating power circuits. Convergence problems can be minimized by paying special attention to:

- Model parameters of diodes and transistors
- Error tolerances
- Snubbing resistor
- Quasi-steady-state conditions

### 15.9.1 MODEL PARAMETERS OF DIODES AND TRANSISTORS

The default values of all parasitic resistances and capacitances in `.MODEL` statements are zero. If the parameters `RS` and `CJO` are not specified in a `.MODEL` statement for a device, it will have no ohmic resistance and no junction capacitance. With `RS = 0`, the circuit may not be able to limit the forward current through the device, and the current can easily become large enough to cause numerical problems. With `CJO = 0` (and `TT = 0`), the device will have zero switching time and the transient analysis may find itself trying to make a transition

in zero time. This will cause PSpice to make the internal time step smaller and smaller until it gives up and reports a transient convergence problem.

### 15.9.2 ERROR TOLERANCES

The main error tolerance is RELTOL (default = 0.001 = .1%). It is not affected by power circuits. VNTOL is used for setting the most accurate voltage (default = 1  $\mu\text{V}$ ), and ABSTOL is used for setting the most accurate current (default = 1 pA). The dynamic range of PSpice is about 12 orders of magnitude. In a circuit with currents in the kiloampere range, ABSTOL = 1 pA will exceed this range and may cause a convergence problem. For power circuits it is often necessary to adjust ABSTOL higher than its default value of 1 pA. The recommended settings for VNTOL and ABSTOL are about nine orders of magnitude smaller than the typical voltages and currents in the circuit. Almost all power circuits should work with the settings:

ABSTOL = 1  $\mu\text{A}$  For a circuit with currents in the kiloampere range  
 ABSTOL = 1 mA For a circuit with currents in the megaampere range  
 VNTOL = 1  $\mu\text{V}$  For a circuit with voltages in the kilovolt range

### 15.9.3 SNUBBING RESISTOR

In circuits containing inductors, there may be spurious ringing between the inductors and parasitic capacitances. Let us consider the diode circuit of [Figure 15.7](#) with  $L = 1$  mH. The parasitic capacitance of the bridge can ring against the inductor with a very high frequency, on the order of megahertz. This ringing is the result of parasitic capacitance only, not the actual behavior of the circuit. During transient simulation, PSpice will take unnecessary small internal time steps and cause a convergence problem. The simplest solution is to add a snubbing resistor  $R_{\text{snub}}$  as shown by dashed lines in [Figure 15.7](#). The value of  $R_{\text{snub}}$  should be chosen to match the impedance of the inductor at the corner frequency of the circuit. At low frequencies, the impedance of  $L$  is low, and  $R_{\text{snub}}$  has little effect on the circuit's behavior. At high frequencies, the impedance of  $L$  is high, and  $R_{\text{snub}}$  prevents it from supporting the ringing. The action of  $R_{\text{snub}}$  is similar to the physical mechanisms, primarily eddy current losses, which limit the frequency response of an inductor.

If components in series with an inductor switch off while current is still flowing in the inductor,  $di/dt$  can be high, causing large spikes and convergence problems. A snubbing resistor can keep such spikes to a large but tractable size and thereby eliminate such convergence problems.

### 15.9.4 QUASI-STEADY-STATE CONDITION

Running transient analysis on power switching circuits can lead to long run times. PSpice must keep the internal time step short compared to the switching period, but the circuit's response generally extends over many switching cycles. This

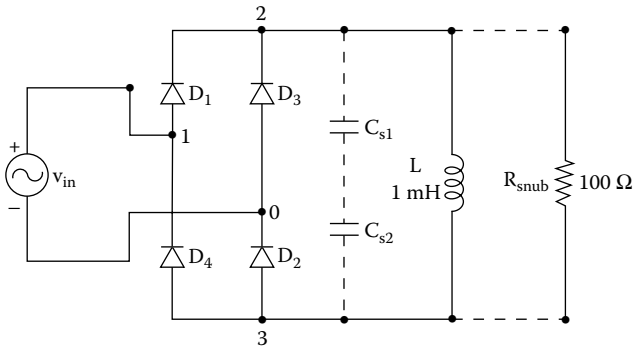


FIGURE 15.7 Diode circuit with snubbing resistor.

problem can be solved by transforming the switching circuit into an equivalent circuit without switching. The equivalent circuit represents a kind of quasi steady state of the actual circuit and can accurately model its response as long as the inputs do not change too fast. This is illustrated in Example 15.3.

### EXAMPLE 15.3 TRANSIENT RESPONSE OF A SINGLE-PHASE FULL-BRIDGE INVERTER WITH VOLTAGE-CONTROLLED SWITCHES

A single-phase bridge-resonant inverter is shown in Figure 15.8. The transistors and diodes can be considered as switches whose on-state resistance is  $10 \text{ m}\Omega$  and whose on-state voltage is  $0.2 \text{ V}$ . Plot the transient response of the capacitor voltage and the current through the load from 0 to 2 msec in steps of  $10 \text{ }\mu\text{sec}$ . The output frequency of the inverter is  $f_o = 4 \text{ kHz}$ .

### SOLUTION

When transistors  $Q_1$  and  $Q_2$  are turned on, the voltage applied to the load will be  $V_s$ , and the resonant oscillation will continue for the entire resonant period, first through  $Q_1$  and  $Q_2$  and then through diodes  $D_1$  and  $D_2$ . When transistors  $Q_3$  and  $Q_4$

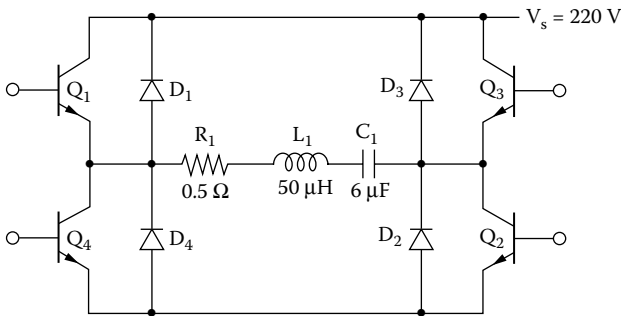


FIGURE 15.8 Single-phase bridge-resonant inverter.

are turned on, the load voltage will be  $-V_{s_s}$ , and the oscillation will continue for another entire period, first through  $Q_3$  and  $Q_4$  and then through diodes  $D_3$  and  $D_4$ . The resonant period of the circuit is calculated approximately as

$$\omega_r = \left( \frac{1}{LC} - \frac{R^2}{4L^2} \right)^{1/2}$$

For  $L = L_1 = 50 \mu\text{H}$ ,  $C = C_1 = 6 \mu\text{F}$ , and  $R = R_1 + R_{1(\text{sat})} + R_{2(\text{sat})} = 0.5 + 0.2 + 0.2 = 0.54 \Omega$ ,  $\omega_r = 57572.2 \text{ rad/sec}$ , and  $f_r = \omega_r/2\pi = 9162.9 \text{ Hz}$ . The resonant period is  $T_r = 1/f_r = 1/9162.9 = 109.1 \mu\text{sec}$ . The period of the output voltage is  $T_o = 1/f_o = 1/4000 = 250 \mu\text{sec}$ .

The switching action of the inverter can be represented by two voltage-controlled switches as shown in Figure 15.9(a). The switches are controlled by voltages as shown in Figure 15.9(b). The on time of switches, which should be approximately equal to the resonant period of the output voltage, is assumed to be  $112 \mu\text{sec}$ . Switch  $S_2$  is delayed by  $115 \mu\text{sec}$  to take account of overlap. The model parameters of the switches are  $\text{RON} = 0.01$ ,  $\text{ROFF} = 10\text{E}+6$ ,  $\text{VON} = 0.001$ , and  $\text{VOFF} = 0.0$ .

The PSpice schematic with voltage-controlled switches is shown in Figure 15.10. The listing of the circuit file is as follows:

### Example 15.3 Full-bridge resonant inverter

```

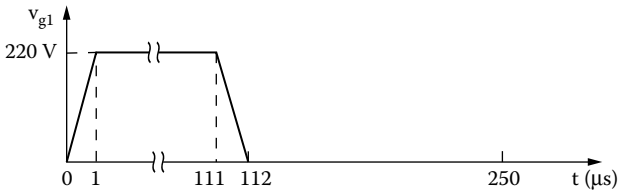
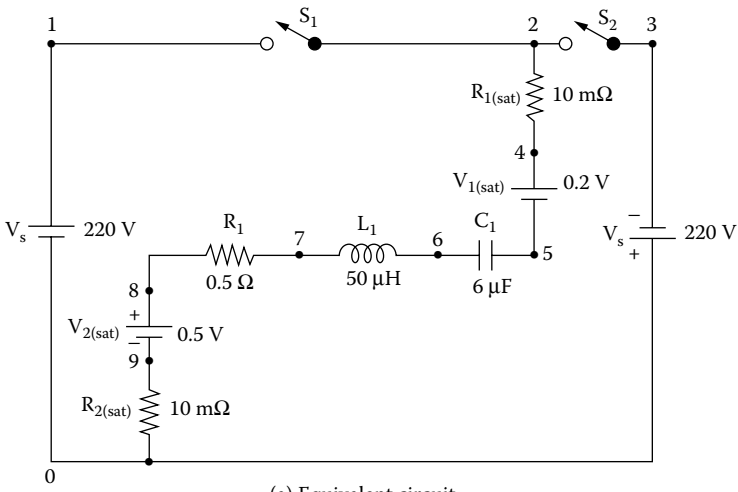
SOURCE ■ * The controlling voltage for switch S1:
V1 1 0 PULSE(0220V01US1US110US250US)
* The controlling voltage for switch S2 with a delay time
of 115 μs:
V2 3 0 PULSE(0-220V115US1US1US110US250US)
CIRCUIT ■■ S1 1 2 1 0 SMOD ; Voltage-controlled switches
S2 2 3 0 3 SMOD
* Switch model parameters for SMOD:
.MODEL SMOD VSWITCH (RON=0.01 ROFF=10E+10E+6 VON=0.001
VOFF=0.0)
RSAT1 2 4 10M
VSAT1 4 5 DC 0.2V
RSAT2 9 0 10M
VSAT2 8 9 DC 0.2V
* Assuming an initial capacitor voltage of -250V to
reduce settling time:
C1 5 6 6UF IC=-250V
L1 6 7 50UH
R1 7 8 0.5

```

```

ANALYSIS ■■■ *Transient analysis with UIC condition:
      .TRAN 1US 500US UIC      ; Transient analysis with UIC
      condition
      .PROBE                    ; Graphics post-processor
      .END
    
```

The transient response for Example 15.3 is shown in [Figure 15.11](#).



**FIGURE 15.9** Equivalent circuit for [Figure 15.8](#). (a) Equivalent circuit, (b) controlling voltages.

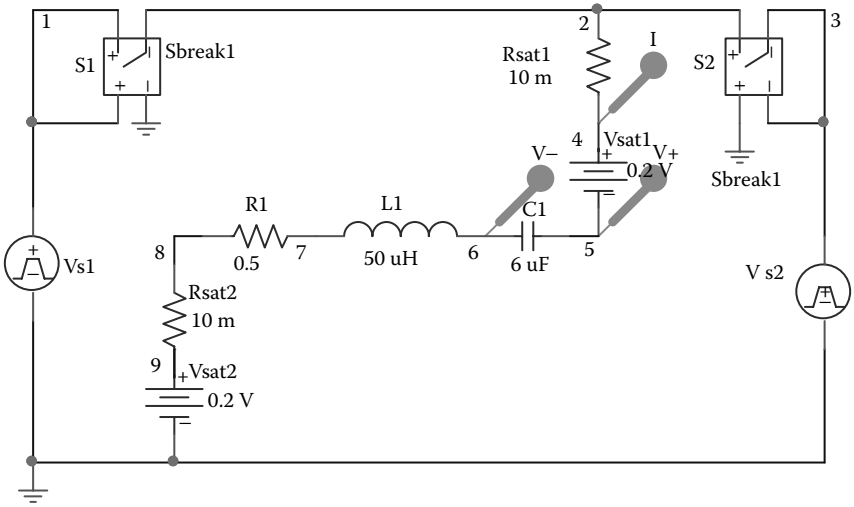


FIGURE 15.10 PSpice schematic for Example 15.3.

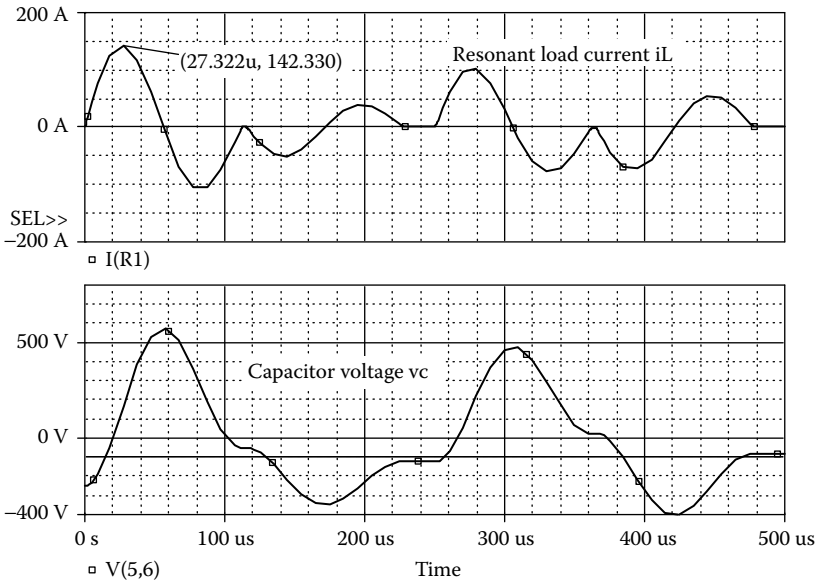


FIGURE 15.11 Transient responses for Example 15.3.

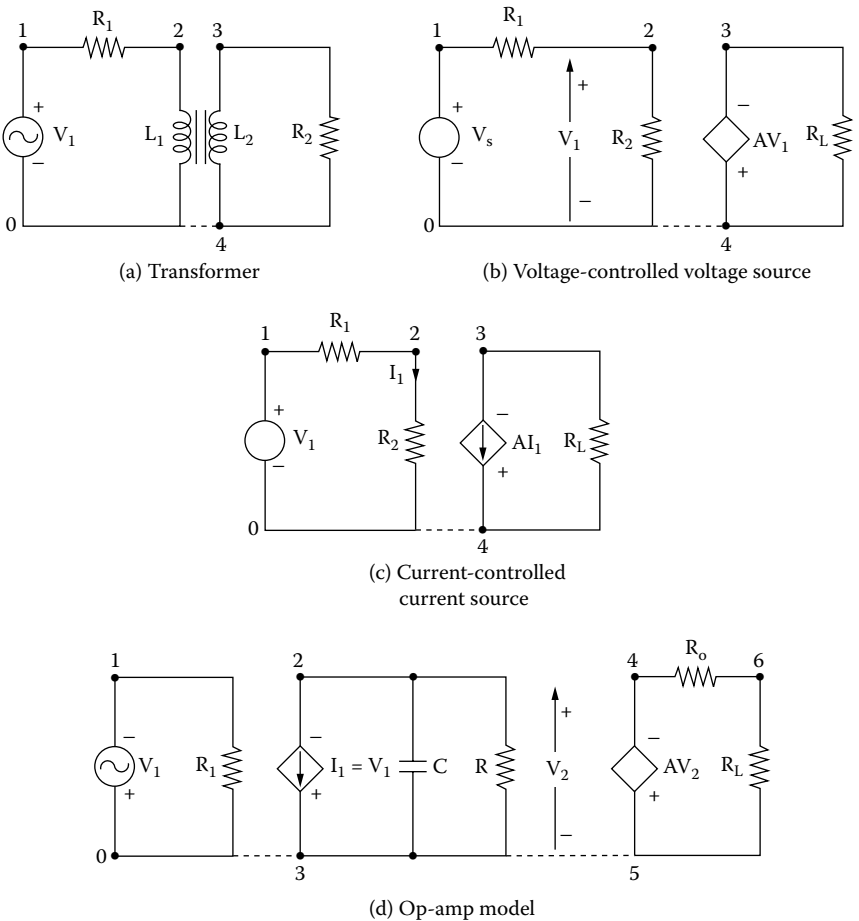
### 15.10 FLOATING NODES

PSpice requires that there be no floating nodes. If there are any, PSpice will indicate a read-in error on the screen, and the output file will contain a message similar to

ERROR: Node 15 is floating

This means that there is no DC path from node 15 to ground. A DC path is a path through resistors, inductors, diodes, and transistors. This is a very common problem, and it can occur in many circuits, as shown in Figure 15.12.

Node 4 in Figure 15.12(a) is floating and does not have a DC path. This problem can be avoided by connecting node 4 to node 0 as shown by dashed lines (or by connecting node 3 to node 2). A similar situation can occur in voltage-controlled and current-controlled sources as shown in Figure 15.12(b) and Figure 15.12(c). The model of op-amps as shown in Figure 15.12(d) has many floating nodes, which should be connected to provide DC paths to ground. For examples, nodes 0, 3, and 5 could be connected together or, alternatively, nodes 1, 2, and 4 may be joined together.



**FIGURE 15.12** Typical circuits with floating nodes. (a) Transformer, (b) voltage-controlled voltage source, (c) current-controlled current source, (d) op-amp model.

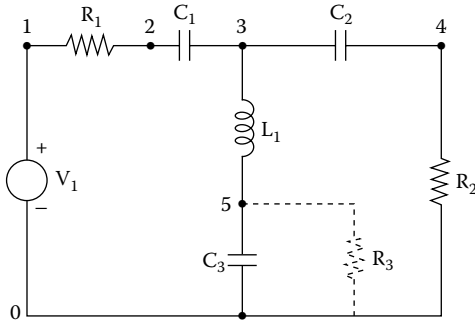


FIGURE 15.13 Typical circuit without DC path.

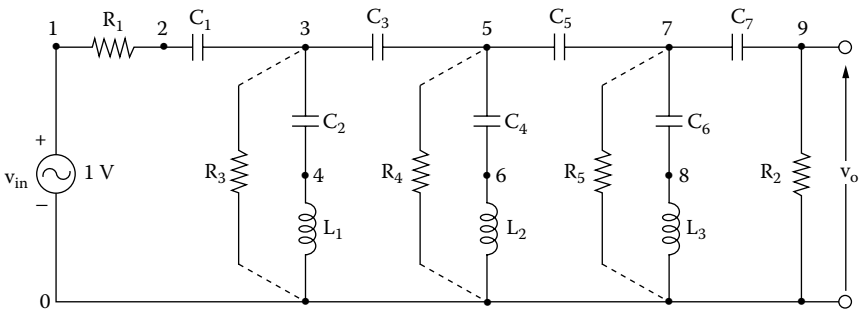
The two sides of a capacitor have no DC path between them. If there are many capacitors in a circuit as shown in Figure 15.13, nodes 3 and 5 do not have DC paths. DC paths can be provided by connecting a very large resistance  $R_3$  (say,  $100\text{ M}\Omega$ ) across capacitor  $C_3$ , as shown by dashed lines.

**EXAMPLE 15.4 PROVIDING DC PATHS TO A PASSIVE FILTER**

A passive filter is shown in Figure 15.14. The output is taken from node 9. Plot the magnitude and phase of the output voltage separately against the frequency. The frequency should be varied from 100 Hz to 10 kHz in steps of one decade and 101 points per decade.

**SOLUTION**

The nodes between  $C_1$  and  $C_3$ ,  $C_3$  and  $C_5$ , and  $C_5$  and  $C_7$  do not have DC paths to the ground. Therefore, the circuit cannot be analyzed without connecting resistors



- $R_1 = 10\text{ k}\Omega, R_2 = 10\text{ k}\Omega, R_3 = R_4 = R_5 = 200\text{ M}\Omega$
- $C_1 = 7\text{ nF}, C_2 = 70\text{ nF}, C_3 = 6\text{ nF}, C_4 = 22\text{ nF}, C_5 = 7.5\text{ nF},$
- $C_6 = 12\text{ nF}, C_7 = 10.5\text{ nF}, L_1 = 1.5\text{ mH}$
- $L_2 = 1.75\text{ mH}, L_3 = 2.5\text{ mH}$

FIGURE 15.14 Passive filter.

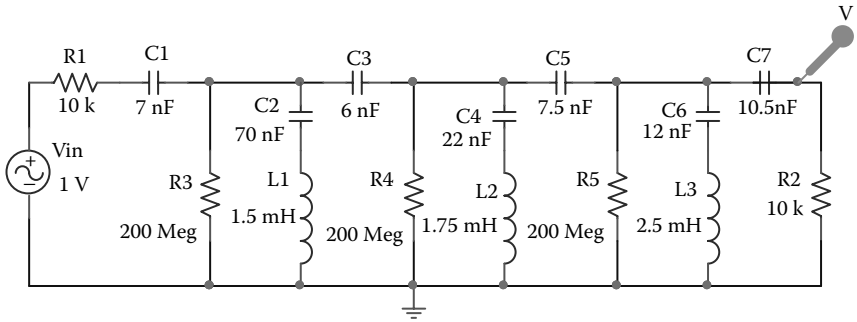


FIGURE 15.15 PSpice schematic for Example 15.4.

$R_3$ ,  $R_4$ , and  $R_5$  as shown in Figure 15.14 by dashed lines. If the values of these resistances are very high, say 200 M $\Omega$ , their influence on the AC analysis would be negligible.

The PSpice schematic of a passive filter with DC paths is shown in Figure 15.15.

The listing of the circuit file is as follows:

### Example 15.4 Passive filter

**SOURCE** ■ VIN 1 0 AC 1V ; Input voltage is 1 V peak

**CIRCUIT** ■■ R1 1 2 10K

R2 9 0 10K

\* Resistances  $R_3$ ,  $R_4$ , and  $R_5$  are connected to provide DC paths:

R3 3 0 200MEG

R4 5 0 200MEG

R5 7 0 200MEG

C1 2 3 7NF

C2 3 4 70NF

C3 3 5 6NF

C4 5 6 22NF

C5 5 7 7.5NF

C6 7 8 12NF

C7 7 9 10.5NF

L1 4 0 1.5MH

L2 6 0 1.75MH

L3 8 0 2.5MH

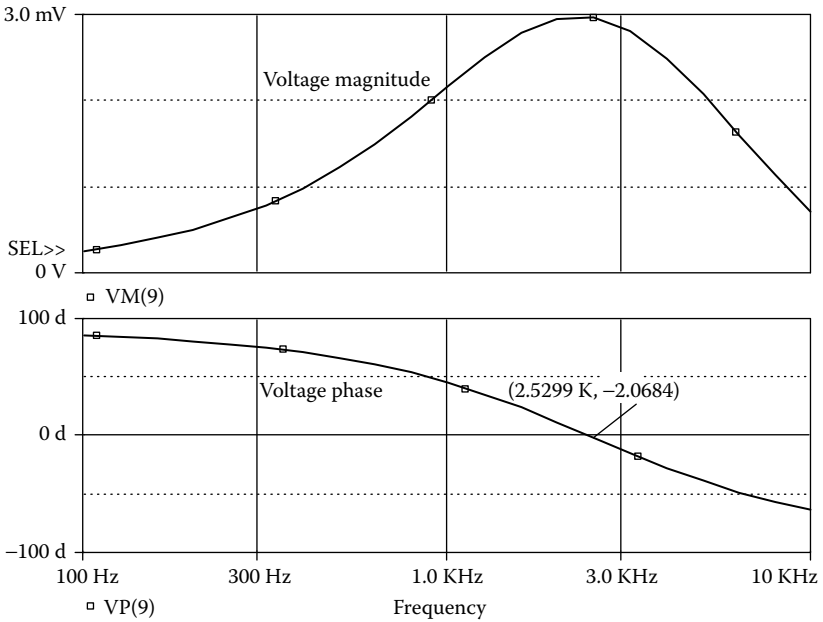
**ANALYSIS** ■■■ \* AC analysis for 100 Hz to 10 kHz with a decade  
\* increment and 101 points per decade:

.AC DEC 101 100 10KHZ

```

* Plot the results of AC analysis for the magnitude
* of voltage at node 9.
.PLOT AC VM(9) VP(9) ; Plots on output file
.PLOT AG VP(9) file ; Plots on output
.PROBE ; Graphics post-processor
.END

```



**FIGURE 15.16** Frequency response for Example 15.4.

The frequency response for Example 15.4 is shown in Figure 15.16.

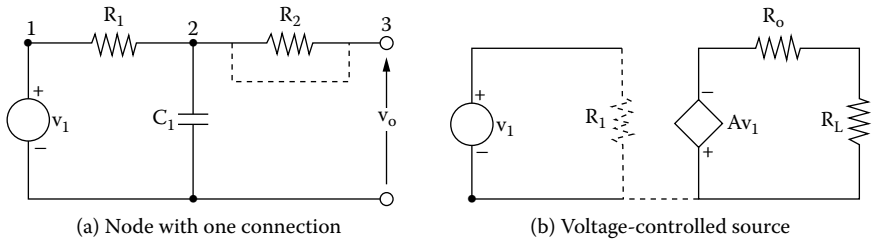
### 15.11 NODES WITH FEWER THAN TWO CONNECTIONS

PSpice requires that every node be connected to at least two other nodes. Otherwise, PSpice will give an error message similar to

```
ERROR: Fewer than two connections at node 10
```

This means that node 10 must have at least another connection. A typical situation is shown in Figure 15.17(a), where node 3 has only one connection. This problem can be solved by short-circuiting resistance  $R_3$  as shown by dashed lines.

An error message may be indicated in the output file for a circuit with voltage-controlled sources as shown in Figure 15.17(b). The input to the voltage-controlled source will not be considered to have connections during the check by



**FIGURE 15.17** Typical circuits with less than two connections at a node. (a) Node with one connection, (b) voltage-controlled source.

PSpice. This is because the input draws no current, and it has infinite impedance. A very high resistance (say,  $10\text{ G}\Omega$ ) may be connected from the input to the ground as shown by dashed lines.

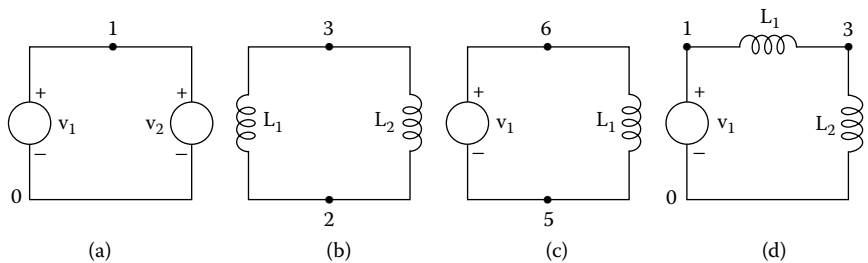
## 15.12 VOLTAGE SOURCE AND INDUCTOR LOOPS

PSpice requires that there be no loops with zero resistance. Otherwise, PSpice will indicate a read-in error on the screen, and the output file will contain a message similar to

```
ERROR: Voltage loop involving V5
```

This means that the circuit has a loop of zero-resistance components, one of which is V5. The zero-resistance components in PSpice are independent voltage sources ( $V$ ), inductors ( $L$ ), voltage-controlled voltage sources ( $E$ ), and current-controlled voltage sources ( $H$ ). Typical circuits with such loops (with  $V$  and  $L$ ) are shown in Figure 15.18.

It does not matter whether the values of the voltage sources are zero or not. Having a voltage source of  $E$  in a zero resistance, the program will need to divide  $E$  by 0. But because  $E = 0\text{ V}$ , the program will need to divide 0 by 0, which is also impossible. It is therefore the presence of a zero-resistance loop that is the problem, not the values of the voltage sources. A simple solution is to add a series resistance to at least one component in the loop. The resistor's value should be



**FIGURE 15.18** Typical circuits with zero-resistance loops.

small enough so that it does not disturb the operation of the circuit. However, the resistor's value should not be less than  $1\ \mu\Omega$ .

### 15.13 RUNNING PSpICE FILES ON SPICE

PSpice will give essentially the same results as Berkeley SPICE 2G (referred to as SPICE). There could be small differences, especially for values crossing zero due to the corrections made for convergence problems. The semiconductor device models are the same as in SPICE.

There are a number of PSpice features that are not available in SPICE. These are:

1. Extended syntax for output variables (e.g., in .PRINT and .PLOT). SPICE allows only voltages of the form  $V(x)$  or  $V(x,y)$  and currents through voltage sources. Group delay is not available.
2. Extra devices:
  - Gallium arsenide model
  - Nonlinear magnetic (transformer) model
  - Voltage- and current-controlled switch models
3. Optional models for resistors, capacitors, and inductors. Temperature coefficients for capacitors and inductors and exponential temperature coefficients for resistors are not available.
4. The model parameters RG, RDS, L, W, and WD are not available in the MOSFET's .MODEL statement in SPICE.
5. Extensions to the DC sweep. SPICE restricts the sweep variable to be the value of an independent current or voltage source. SPICE does not allow sweeping of model parameters or temperature.
6. The .LIB and .INCLUDE statements.
7. SPICE requires the input (.CIR) file to be uppercase.

### 15.14 RUNNING SPICE FILES ON PSpICE

PSpice can run any circuit that Berkeley SPICE 2G can run with the following exceptions:

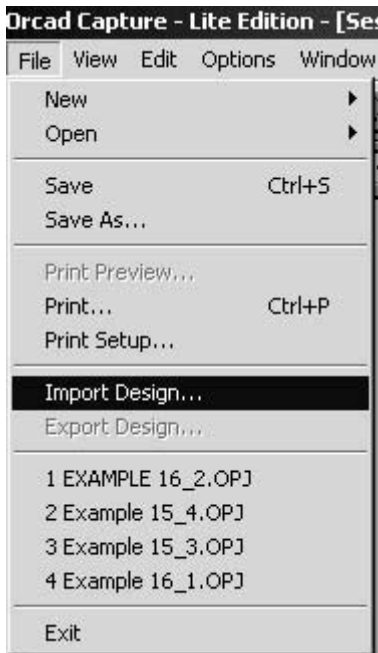
1. Circuits that use .DISTO (small-signal distortion) analysis, which has errors in Berkeley SPICE. Also, the special distortion output variables (HD2, DIM3, etc.) are not available. Instead of the .DISTO analysis, we recommend running a transient analysis and looking at the output spectrum with the Fourier transform mode of Probe. This technique shows the distortion (spectral) products for both small-signal and large-signal distortion.

2. The IN = option of the .WIDTH statement is not available. PSpice always reads the entire input file regardless of how long the input lines are.
3. Temperature coefficients for resistors must be put into a .MODEL statement instead of into the resistor statement. Similarly, the voltage coefficients for capacitors and the current coefficients for inductors are used in the .MODEL statements.

## 15.15 USING EARLIER VERSION OF SCHEMATICS

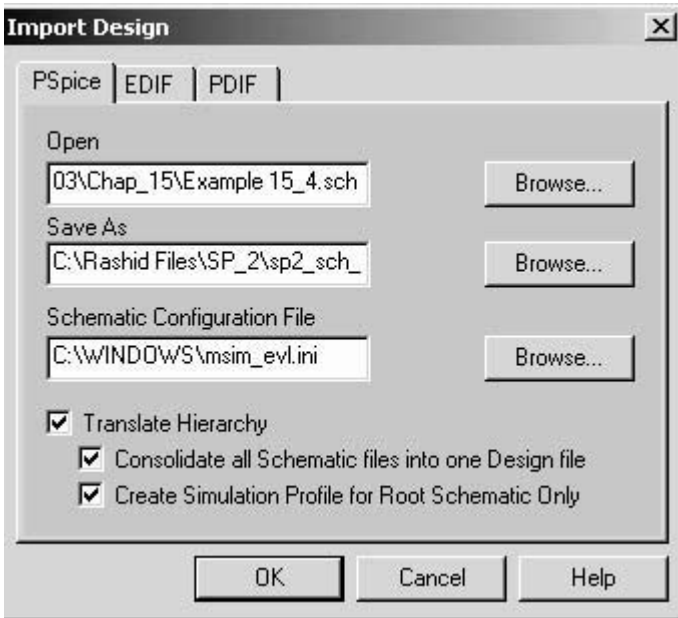
PSpice schematics is being continuously improved with new versions. However, all versions have the same platform, and the schematic files have the extension .slb. Thus, a new version can run schematic files drawn in earlier versions.

OrCAD, Inc., owns Microsim PSpice. The OrCAD platform is slightly different from the PSpice Schematics platform. The file extension is .OPJ. The PSpice schematic files can be imported to OrCAD Capture as shown in Figure 15.19(a). It will require identifying the location of the schematic configuration



(a)

**FIGURE 15.19** Importing PSpice schematic files to OrCAD Capture (a) OrCAD Capture, (b) importing PSpice schematic to OrCAD capture.



(b)

**FIGURE 15.19** (continued).

file: C:\WINNT\msim\_evl.ini as shown in Figure 15.19(b). OrCAD's PSpice AD Lite Edition can run all PSpice files with extension .CIR.

## SUGGESTED READING

1. *PSpice Manual*, Irvine, CA: MicroSim Corporation, 1992.
2. W. Blume, Computer circuit simulation, *Byte*, Vol. 11, No. 7. July 1986, p. 165.
3. *PSpice 9.1 Student Version*. San Jose, CA: Cadence Design Systems, 2001. <http://www.cadencepcb.com/products/downloads/PSpicestudent/default.asp>.
4. *Orcad 9.2 Demo*. San Jose, CA: Cadence Design Systems, 2001. <http://www.cadencepcb.com/products/downloads/orcaddemo/default.asp>.
5. *PSpice Design Community*. San Jose, CA: Cadence Design Systems, 2001. <http://www.PSpice.com>.

## PROBLEMS

### 15.1

For the inverter circuit in [Figure P15.1](#), plot the hysteresis characteristics. The input voltage is varied slowly from  $-5$  to  $+5$  V and from  $+5$  to  $-5$  V. The model parameters of the PMOS are  $V_{TO} = -2.5$ ,  $K_P = 4.5E-3$ ,  $CBD = 5PF$ ,  $CBS = 2PF$ ,  $CGSO = 1PF$ ,  $CGDO = 1PF$ , and  $CGBO = 1PF$ .

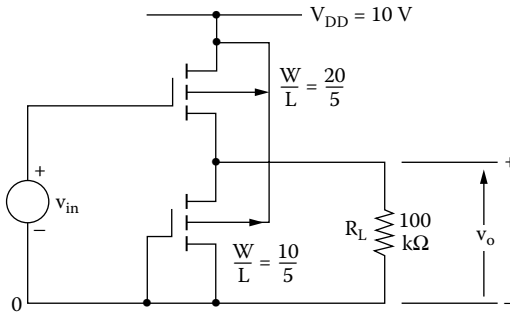


FIGURE P15.1 Inverter circuit.

## 15.2

For the circuit in Figure P15.2, plot the hysteresis characteristics from the results of the transient analysis. The input voltage is varied slowly from  $-4$  to  $+4$  V and from  $+4$  to  $-4$  V. The op-amp can be modeled as a macromodel, as shown in Figure 13.3. The description of the macromodel is listed in library file EVAL.LIB. The supply voltages are  $V_{CC} = 12$  V and  $V_{EE} = -12$  V.

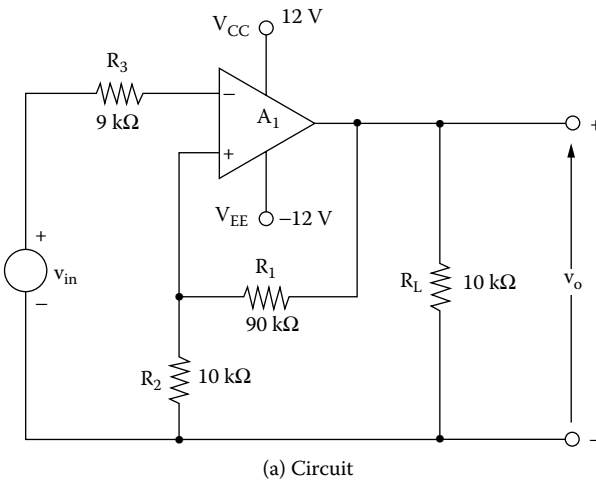
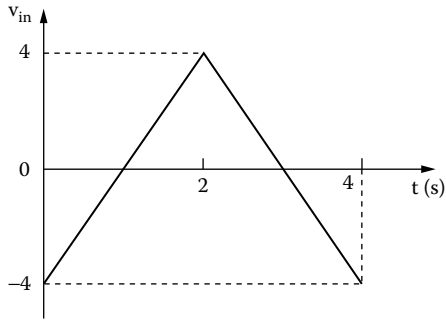


FIGURE P15.2 Op-amp hysteresis circuit.



(b) Input voltage

**FIGURE P15.2** (continued).

---

# APPENDIX A

## Running PSpice on PCs

PSpice programs are available in CDs. The first step is to have the directory listing of the files on the program CDs. The next step is to print and read the README.DOC file. It contains a brief description of the type of display and hard copy that are allowed by PSpice and Probe. It also contains the system requirements and instructions for running PSpice programs.

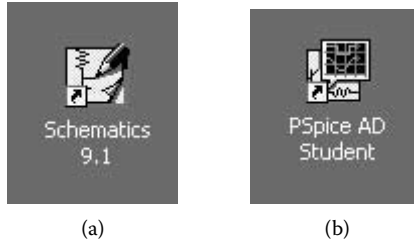
PSpice will run on any IBM-PC, Macintosh II, or compatible computer. The student version of PSpice does not require the coprocessor for running Probe. The display could be on monochrome or color graphics monitors. There is no requirement of special features for printers. The types of printers and display can be set by editing the PROBE.DEV file or the setup menu. The simulation of a circuit requires:

- Installing PSpice software in PCs
- Creating input circuit files
- Run command
- DOS (disk operating system) commands
- PSpice Default Symbol Libraries

### A.1 INSTALLING PSPICE SOFTWARE IN PCS

The steps to be followed to install a PSpice program in PCs with a hard drive are:

1. Place the Schematics CD ROM in the CD drive.
2. From Windows, enter the File Manager, and click with the left mouse button (**CLICKL**) on the CD drive.
3. **CLICKL** on setup.exe, **File, Run, OK**.
4. **OK**, to select Install Schematics and PSpice A/D.
5. **OK**, to select default C:OrCAD Dem.
6. **Yes**, to create Design Center icons as shown in [Figure A.1](#).
7. Click with the left mouse button once on the Design Center icon; the window of the Design Center will open.

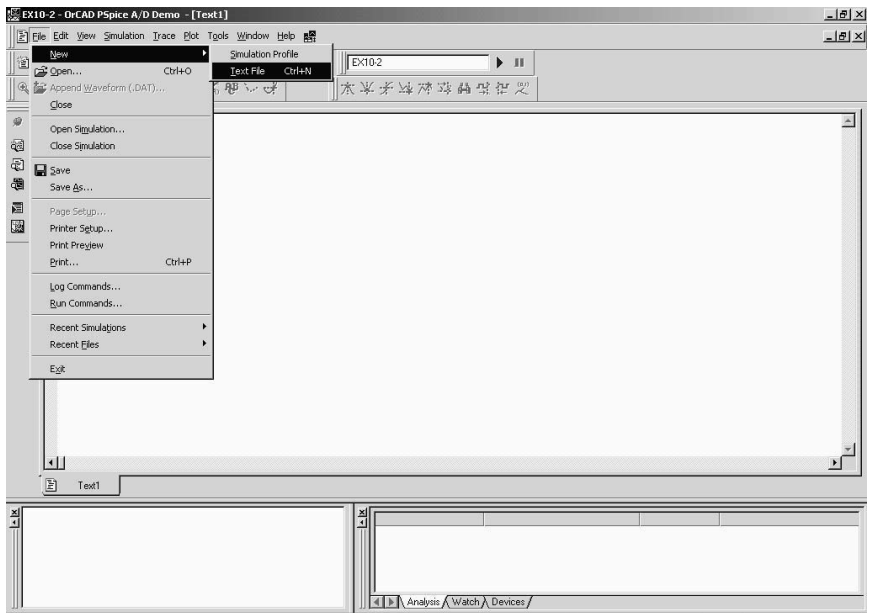


**FIGURE A.1** Icons of PSpice Schematics and PSpice A/D. (a) Schematics, (b) PSpice A/D.

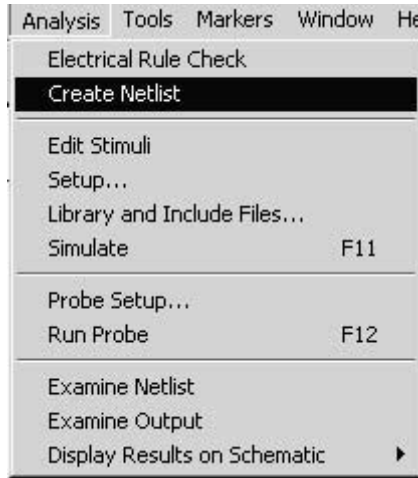
## A.2 CREATING INPUT CIRCUIT FILES

The PSpice program has a built-in editor with shell, as shown in Figure A.2. The net list or the input circuit file can be created by choosing Create Netlist from the Analysis menu of PSpice Schematics as shown in Figure A.3. The input file can also be created by text editors. The text editor that is always available is EDLIN. It comes with DOS and is described in the DOS user's guide. Notepad or WordPad in Accessories within Programs in the Windows environment can also be used.

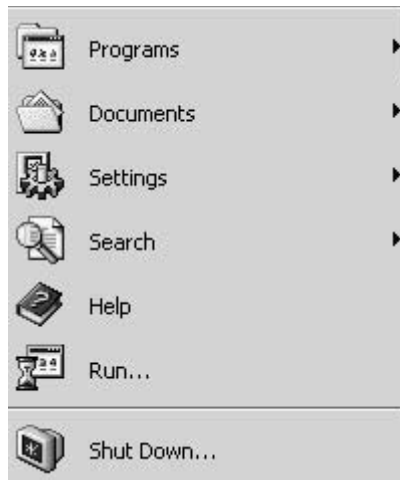
The Accessories folder within the Programs folder on the Start menu is shown in Figure A.4. There are other editors such as Program Editor (from WordPerfect



**FIGURE A.2** OrCAD PSpice A/D platform.



**FIGURE A.3** Creating Netlists from PSpice Schematics.



(a)

**FIGURE A.4** Selecting text editor from Window programs.

Corporation). Word processing programs such as WordStar 2000, WordPerfect, and MSWord may also be used to create the input file. The word processor normally creates a file that is not a text file. It contains embedded characters to determine margins, paragraph boundaries, pages, etc. However, most word processors have a command or mode to create a text file without those control characters. For example, WordStar 2000 creates text files with the UNIFORM format.



FIGURE A.4 (continued).

### A.3 RUNNING DOS COMMANDS

In the Windows environment, DOS commands are enabled from the Command Prompt, which is selected from the Windows Start menu, and then the Accessories submenu as shown in Figure A.5. Selecting Command Prompt opens the menu for DOS commands as shown in Figure A.6.

The DOS commands that are frequently used are as follows:

To format a brand new diskette on drive A:, type

```
FORMAT A:
```

To list the directory of a diskette on drive A:, type

```
DIR A:
```

To delete the file EX2-1.CIR on drive A:, type

```
Delete A: EX2-1.CIR (or Erase A: EX2-1.CIR)
```



**FIGURE A.5** Selecting Command Prompt in the Windows environment.

To copy the file EX2-1.CIR on drive A: to the file EX2-2.CIR on drive B:, type  
`COPY A:EX2-1.CIRB:EX2-2.CIR`

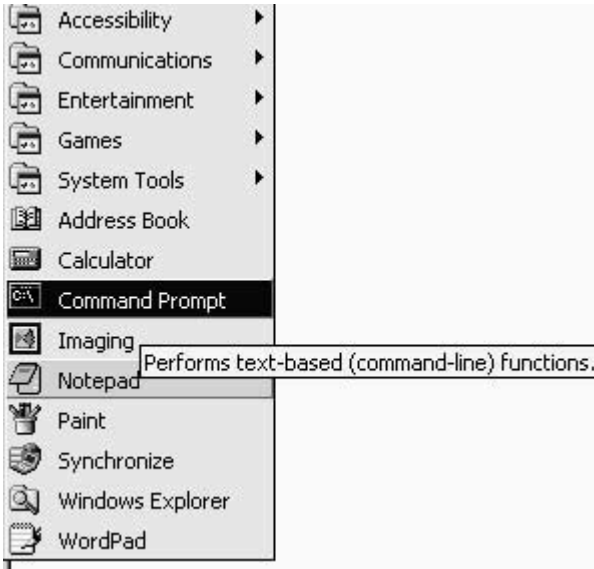
To copy all the files on a diskette in drive A: to a diskette on drive B:, type  
`COPY A: *.*B:`

To type the contents of the EX2-1.OUT on drive A:,  
`TYPE A: EX2-1.OUT`

To print the contents of the file EX2-1.CIR on drive A:, first activate the printer by pressing Ctrl (Control) and Prtsc (Print Screen) keys together and then type

`TYPE A: EX2-1.CIR`

The printer can be deactivated by pressing the Ctrl (control) and Prtsc (print screen) keys again.



(c)

FIGURE A.5 (continued).



FIGURE A.6 Command Prompt menu.

#### A.4 PSPICE DEFAULT SYMBOL LIBRARIES

The student version of PSpice allows a maximum of ten configured (addressable) symbol libraries at a given time. It has nine default libraries (with an extension .slb) as shown in [Figure A.7](#). Their functions are described below:

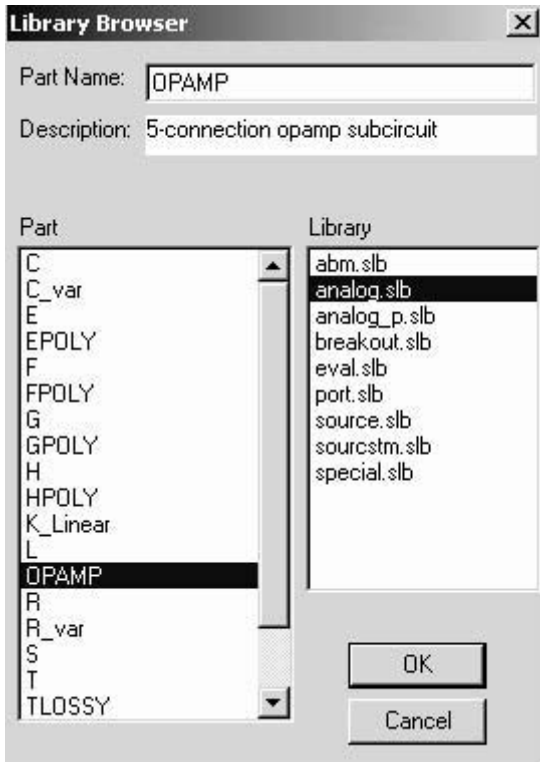


FIGURE A.7 PSpice default symbol libraries

1. **abm.slb:** Analog behavior models for voltage and current sources whose outputs can be controlled by mathematical expressions or tabular data and a Laplace transform block.
2. **analog.slb:** Analog components for passive components ( $R$ ,  $L$ ,  $C$ ), coupled inductors, and dependent voltage and current sources.
3. **analog\_p.slb:** Passive components ( $R$ ,  $L$ ,  $C$ ) with parameterized values.
4. **breakout.slb:** Passive and active components in a simplified generic or default configuration. It is useful for circuits when detailed models, especially for active devices, are not available.
5. **eval.slb:** Detailed models for a few specific devices such as Q2N2222 for BJT, J2N3819 for JFET, uA741 op-amp, and IRF150 power MOSFET.
6. **port.slb:** Different ports and pins for specifying node connections without having to have a directly drawn wire connection. It also includes ground connection or symbol.
7. **source.slb:** Independent current and voltage source models. Different models of a voltage (or a current) source are used depending on the type of analysis such AC sweep, DC sweep, and transient analysis.

8. `sourcestm.slb`: Specialized models of voltage and current source for use with Edit Stimulus command in Analysis menu.
9. `special.slb`: Specialized parts such as PARAM (short for Parameters) for creating parameterized simulations.

The user can add or remove libraries as desired within the maximum limit of ten. Thus, the user can add at least one library without removing any of the PSpice default libraries. The `sourcestm.slb` and `analog_p.slb` libraries, which are not often needed, can be removed to make room for other libraries.

---

# Bibliography

- Allen, P.E., *CMOS Analog Circuit Design*, New York: Holt, Rinehart and Winston, 1987.
- Antognetti, P. and Guisepppe M., *Semiconductor Device Modeling with SPICE*, New York: McGraw-Hill, 1988.
- Banzhaf, W., *Computer-Aided Circuit Analysis Using SPICE*, Englewood Cliffs, NJ: Prentice Hall, 1989.
- Bugnola, D.S., *Computer Programs for Electronic Analysis and Design*, Reston, VA: Reston Publishing Company, 1983.
- Chattergy, R., *SPICEY Circuits: Elements of Computer-Aided Analysis*, Boca Raton, FL: CRC Press, 1992.
- Chua, L.O. and Pen-Min, L., *Computer-Aided Analysis of Electronic Circuits: Algorithms and Computational Techniques*, Englewood Cliffs, NJ: Prentice Hall, 1975.
- Ghandi, S.K., *Semiconductor Power Devices*, New York: Wiley, 1977.
- Gray, P.R. and Meyer, R.G., *Analysis and Design of Analog Integrated Circuits*, New York: Wiley, 1984.
- Grove, A.S., *Physics and Technology of Semiconductor Devices*, New York: Wiley, 1967.
- Hodges, D.A. and Jackson, H.G., *Analysis and Design of Digital Integrated Circuits*, New York: McGraw-Hill, 1988.
- McCalla, W.J., *Fundamentals of Computer-Aided Circuit Simulation*, Norwell, MA: Kluwer Academic, 1988.
- Nagel, L.W., *SPICE2: A Computer Program to Simulate Semiconductor Circuits*, Memorandum ERL-M520, May 1975, Electronics Research Laboratory, University of California, Berkeley.
- Nashelsky, L. and Boylestad, R.L., *BASIC for Electronics and Computer Technology*, Englewood Cliffs, NJ: Prentice Hall, 1988.
- PSpice Manual*, Irvine, CA: MicroSim Corporation, 1992.
- Rashid, M.H., *Power Electronics: Circuits, Devices, and Applications*, 2nd ed., Englewood Cliffs, NJ: Prentice Hall, 1993.
- Rashid, M.H., *SPICE for Circuits and Electronics Using PSpice*, Englewood Cliffs, N.J.: Prentice Hall, 1990.
- Spence, R. and Burgess, J.P., *Circuit Analysis by Computer: From Algorithms to Package*. London: Prentice Hall International (U.K.), 1986.
- Tuinenga, P.W., *SPICE: A Guide to Circuit Simulation and Analysis Using PSpice*, 2nd ed., Englewood Cliffs, NJ: Prentice Hall, 1992.
- van der Ziel, A., *Noise in Solid State Deices*. New York: Wiley, 1986.

---

## Reference Table I

Circuit Elements and Sources	First Letter	Model Type Name
Bipolar junction transistor	Q	NPN/PNP
Capacitor	C	CAP
Current-controlled current source	F	
Current-controlled switch	W	ISWITCH
Current-controlled voltage source	H	
Diode	D	D
Exponential source		EXP
GaAs MES field-effect transistor	B	GASFET
Independent current source	I	
Independent voltage source	V	
Inductor	L	IND/CORE
Junction field-effect transistor	J	NJF/PJF
MOS field-effect transistor	M	NMOS/PMOS
Mutual inductors (transformer)	K	
Piecewise linear source		PWL
Polynomial source		POLY(n)
Pulse source		PULSE
Resistor	R	RES
Single-frequency frequency modulation source		SFFM
Sinusoidal source		SIN
Transmission line	T	
Voltage-controlled current source	G	
Voltage-controlled switch	S	VSWITCH
Voltage-controlled voltage source	E	

---

---

## Reference Table II

<b>Analysis and Functions</b>	<b>Commands</b>
AC or frequency analysis	.AC
DC operating analysis	.OP
DC sweep	.DC
End of subcircuit	.ENDS
Fourier analysis	.FOUR
Frequency response transfer function	.FREQ
Function definition	.FUNC
Global nodes	.GLOBAL
Graphical postprocessor	.PROBE
Include file	.INC
Initial conditions	.IC
Library file	.LIB
Model definition	.MODEL
Node setting	.NODESET
Noise analysis	.NOISE
Options	.OPTIONS
Parameter definition	.PARAM
Parameter variation	.PARAM
Parametric analysis	.STEP
Plot output	.PLOT
Print output	.PRINT
Sensitivity analysis	.SENS
Subcircuit definition	.SUBCKT
Table	TABLE
Temperature	.TEMP
Transfer function	.TF
Transient analysis	.TRAN
Value	VALUE
Width	.WIDTH

---